



**GE INDUSTRIAL MOTORS**  
a **WOLONG** company

# Product Technical Information

April 1, 2021

Data shown is for the current revision model #. Ensure your nameplate model # matches.

<b>Model Number:</b>	<b>5KS284SAA115D5</b>
<b>Catalog Number:</b>	<b>M9156</b>
<b>Instruction Manual:</b>	GEI-56128
<b>Connection Diagram:</b>	GEM2034E-FIG9
<b>Outline Drawing:</b>	4002B5828PAP5646

## Accessory Connection Diagrams

<b>Bearing Thermocouple:</b>	None	<b>Heater:</b>	None
<b>RTD:</b>	None	<b>Thermistor:</b>	None
<b>Thermostat:</b>	None	<b>Winding Thermocouple:</b>	None
<b>Bearing RTD:</b>	None		

## Table of Contents

Specification	01
Performance Characteristics	02
Outline Drawing	03
Connection Drawing(s)	04
Spare parts	05

Marks:

<b>MODEL NUMBER:</b>	<b>5KS284SAA115D5</b>	<b>Estimated Weight:</b>	460 Lbs
<b>Outline Drawing:</b>	4002B5828PAP5646	<b>Time Rating:</b>	CONT
<b>Connection Diagram:</b>	GEM2034E-FIG9	<b>Enclosure:</b>	TEFC
<b>Instruction Book:</b>	GEI-56128	<b>Encl Construction:</b>	841
<b>Design Code:</b>	28BD0159A	<b>Ambient Max(°C):</b>	40
<b>Type:</b>	KS	<b>Alt Ambient Max(°C):</b>	--
<b>Frame:</b>	284TS	<b>Insulation Class:</b>	H
<b>Phases:</b>	3	<b>NEMA Design:</b>	B
<b>Poles:</b>	2	<b>Nominal Efficiency:</b>	91.7 %
<b>Output Power:</b>	25HP 18.5KW	<b>Guaranteed Efficiency:</b>	91.0 %
<b>RPM:</b>	3550	<b>3/4 Load Efficiency:</b>	--
<b>Voltage:</b>	230/460	<b>KVA Code:</b>	G
<b>Hertz:</b>	60	<b>Max KVAR:</b>	4.8
<b>Amps - FL:</b>	56.0/28.0	<b>Power Factor:</b>	91.0
<b>Service Factor:</b>	1.15	<b>Bearing - DE:</b>	6310ZC3
<b>Alt Service Factor:</b>	--	<b>Bearing - ODE:</b>	6310ZC3

Enclosure is Totally Enclosed Fan-Cooled

---

Stamped Nameplate Notes:

DE BRG 50BC03JP30 ODE BRG 50BC03JP30  
 EXCEPTION TO IEEE-STD-841-2009: DUAL VOLTAGE  
 STAMP NP249A5564P051 AS BELOW:  
 MODEL:5KS284SAA115D5 S/N: XXX  
 CSA CERTIFIED CSA09.2216219 FOR EX NA IIC 200C GC  
 CL 1 ZONE2 AEX NA IIC 200C;CL 1 DIV2 GRP ABCD 200C  
 IN -40C <= AMB <= 40C, 1.0 SF ON SINE-WAVE PWR  
 SURF TEMP 260C AT 1.15SF ON SINE-WAVE PWR  
 OR 200C VT OR 215C CT OR 215C CHP PWM CONTROL  
 ALTERNATE RATING FOR PWM CONTROL 1.0SF 40C AMB  
 VT 0 - 60 HZ, CT 12-60 HZ, CHP 60-90 HZ.



**Additional Information:**

2P - TS EXTN  
STANDARD FLOOR MOUNT  
C/BOX 137 CU IN-1.50 NPT  
F1 CONDUIT BOX MOUNTING  
PAINTED FRAME ID & SHAFT,  
FAN COVER INSIDE & ODE E/S OUTSIDE  
ROUTINE AND 5 POINT VIBRATION TESTS INCL IN C/BOX  
GROUND SCREW ON FRAME  
SHAFT RUNOUT LIMIT .001" TIR  
OIL RESISTANT SLEEVING ON LEADS



**Performance Characteristics**

1st Winding 1st Connection

**Design: 28BD0159A**

**Marks:**

LOAD %	125.0	115.0	100.0	75.0	50.0	25.0	0.0
% EFF	90.58	91.11	92	92.54	92.43	89.45	0.00
% PF	90.85	91	90.9	89.53	84.78	68.17	8.68
AMPS	35.54	32.46	27.98	21.18	14.93	9.59	6.66

<b>TORQ(FL)#FT</b>	36.99	<b>TORQ(LR)%FL</b>	226.64	<b>TORQ(BD)%FL</b>	268.62
<b>AMPS(LR)</b>	173.61	<b>PF AT START</b>	0.39		

This motor is capable of two cold or one hot start with a maximum connected load inertia of 79 Lb-Ft Sq (3.33 Kg-meter Sq)at 100% voltage, where the load torque varies with the square of the speed. Acceleration time with maximum inertia and the above load type is 18 seconds. Safe stall time at 100% voltage is 40 seconds cold, 22 seconds hot. Rotor inertia is 2.11 Lb-Ft Sq (0.09 Kg-meter Sq).

<b>Open Circuit A-C:</b>	0.793	<b>Short Circuit D-C:</b>	0.013
<b>Short Circuit A-C:</b>	0.027	<b>X/R Ratio:</b>	4.793
<b>Stator Slots:</b>	48	<b>Rotor Slots:</b>	38

**Speed Torque Current Curve (First Connection, First Speed)**

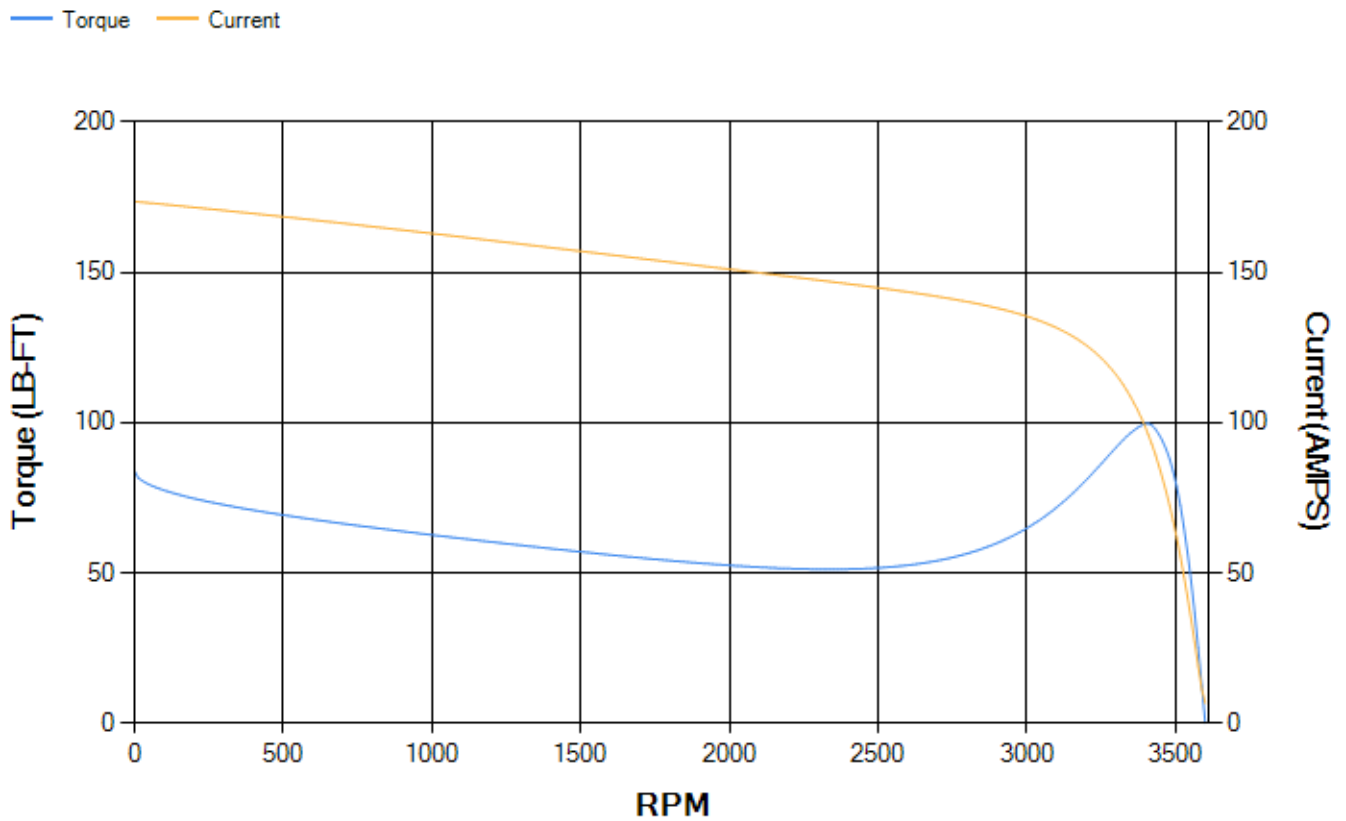

Marks:

NOTE 1: CONDUIT BOX MAY BE ASSEMBLED WITH ENTRANCE UP, DOWN OR TO EITHER SIDE.  
 NOTE 2: FL ASSEMBLY AS SHOWN.  
 NOTE 3: ALL DIMENSIONS ARE IN INCHES & BRACKETED DIMENSIONS ARE IN METRIC (MILLIMETERS)

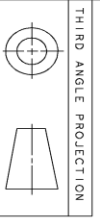
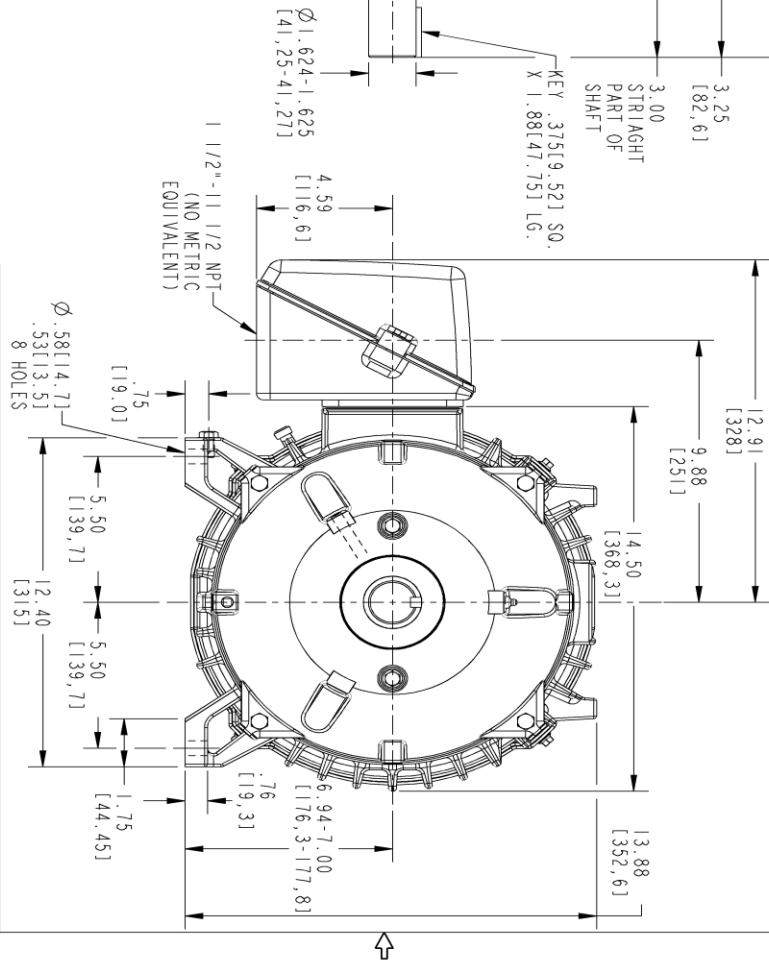
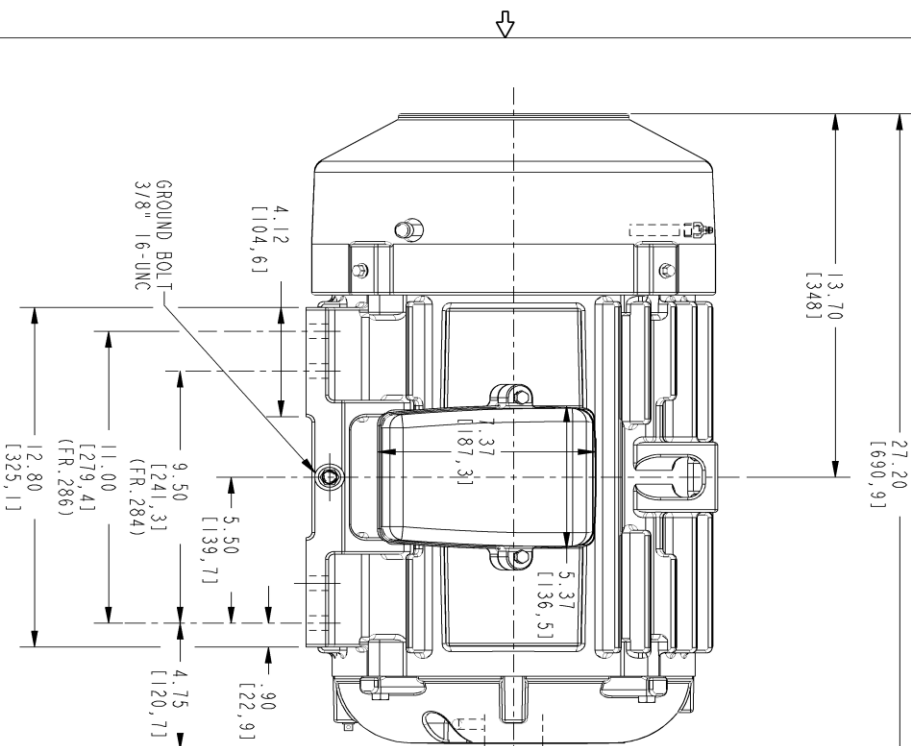

SIZE	DRAWING NO.	REV	SHEET
B	4002B5828PAP5646	0	1

REV.	DESCRIPTION	DATE	APPROVED

SIGNATURES		DATE	<b>GE Motors</b> GENERAL ELECTRIC COMPANY
MODEL	PIVUSH	08/11/16	
DETAIL	PIVUSH	08/11/16	TITLE <b>INDUCTION MOTOR OUTLINE</b> 284/286 T5, TEFC CBOX 137 CUIN - 150 NPT, GROUND PAD
DESIGN	PIVUSH	08/11/16	
ENGR	PIVUSH	08/11/16	
QC	PIVUSH	08/11/16	
QUALITY	PIVUSH	08/11/16	SIZE DRAWING <b>4002B5828PAP5646</b>
ISSID	B	0	SCALE: 0.250 REF. No. 4002B5828PAP5302
SOLD MODEL	4002B5828PAP5646		SHEET 1 of 1

Marks:

**Connection Diagram**  
**GEM2034E-FIG9**



End shield Assembly		
Part Description	DE Side Part#	ODE Side Part#
End Shield	4004D5284PB1	4004D5284SE1
Bearing	235A2508EC01	235A2508EC01
Slinger/Inproseal	149C4399G03	149C4399G03

Fan & Fan Cover Assembly	
Part Description	Part#
Fan	159C6704G02
Fan Cover	4003C5789PA1

Conduit & Accessories Box Assembly	
Part Description	Part#
Conduit Box	4002B5728PA-G01

Mechanical Accessories	
Part Description	Part#
Brake	
Tachometer	

