



**GE INDUSTRIAL MOTORS**  
a **WOLONG** company

# Product Technical Information

April 1, 2021

Data shown is for the current revision model #. Ensure your nameplate model # matches.

<b>Model Number:</b>	<b>5KS284SAA105D2</b>
<b>Catalog Number:</b>	<b>M9174</b>
<b>Instruction Manual:</b>	GEI-56128
<b>Connection Diagram:</b>	GEM2034E-FIG9
<b>Outline Drawing:</b>	4002B5828PAP5943

## Accessory Connection Diagrams

<b>Bearing Thermocouple:</b>	None	<b>Heater:</b>	None
<b>RTD:</b>	None	<b>Thermistor:</b>	None
<b>Thermostat:</b>	None	<b>Winding Thermocouple:</b>	None
<b>Bearing RTD:</b>	None		

## Table of Contents

Specification	01
Performance Characteristics	02
Outline Drawing	03
Connection Drawing(s)	04
Spare parts	05

Marks:

<b>MODEL NUMBER:</b>	<b>5KS284SAA105D2</b>	<b>Estimated Weight:</b>	460 Lbs
<b>Outline Drawing:</b>	4002B5828PAP5943	<b>Time Rating:</b>	CONT
<b>Connection Diagram:</b>	GEM2034E-FIG9	<b>Enclosure:</b>	TEFC
<b>Instruction Book:</b>	GEI-56128	<b>Encl Construction:</b>	841
<b>Design Code:</b>	28BD0159A	<b>Ambient Max(°C):</b>	40
<b>Type:</b>	KS	<b>Alt Ambient Max(°C):</b>	--
<b>Frame:</b>	284T	<b>Insulation Class:</b>	H
<b>Phases:</b>	3	<b>NEMA Design:</b>	B
<b>Poles:</b>	2	<b>Nominal Efficiency:</b>	91.7 %
<b>Output Power:</b>	25HP 18.5KW	<b>Guaranteed Efficiency:</b>	91.0 %
<b>RPM:</b>	3550	<b>3/4 Load Efficiency:</b>	--
<b>Voltage:</b>	230/460	<b>KVA Code:</b>	G
<b>Hertz:</b>	60	<b>Max KVAR:</b>	4.8
<b>Amps - FL:</b>	56.0/28.0	<b>Power Factor:</b>	91.0
<b>Service Factor:</b>	1.15	<b>Bearing - DE:</b>	6310ZC3
<b>Alt Service Factor:</b>	--	<b>Bearing - ODE:</b>	6310ZC3

Enclosure is Totally Enclosed Fan-Cooled

---

Stamped Nameplate Notes:

DE BRG 50BC03JP30 ODE BRG 50BC03JP30  
 EXCEPTION TO IEEE-STD-841-2009: DUAL VOLTAGE  
 STAMP NP249A5564P051 AS BELOW:  
 MODEL:5KS284SAA105D2 S/N: XXX  
 CSA CERTIFIED CSA09.2216219 FOR EX NA IIC 200C GC  
 CL 1 ZONE2 AEX NA IIC 200C;CL 1 DIV2 GRP ABCD 200C  
 IN -40C <= AMB <= 40C, 1.0 SF ON SINE-WAVE PWR  
 SURF TEMP 260C AT 1.15SF ON SINE-WAVE PWR  
 OR 200C VT OR 215C CT OR 215C CHP PWM CONTROL  
 ALTERNATE RATING FOR PWM CONTROL 1.0SF 40C AMB  
 VT 0-60 HZ, CT 12-60 HZ, CHP 60-90 HZ.



**Additional Information:**

2P - T EXTN  
STANDARD FLOOR MOUNT  
C/BOX 137 CU IN-1.50 NPT  
F1 CONDUIT BOX MOUNTING  
PAINTED FRAME ID & SHAFT,  
FAN COVER INSIDE & ODE E/S OUTSIDE  
ROUTINE AND 5 POINT VIBRATION TESTS INCL IN C/BOX  
GROUND SCREW ON FRAME  
SHAFT RUNOUT LIMIT .0015" TIR  
OIL RESISTANT SLEEVING ON LEADS



**Performance Characteristics**

1st Winding 1st Connection

**Design: 28BD0159A**

**Marks:**

LOAD %	125.0	115.0	100.0	75.0	50.0	25.0	0.0
% EFF	90.58	91.11	92	92.54	92.43	89.45	0.00
% PF	90.85	91	90.9	89.53	84.78	68.17	8.68
AMPS	35.54	32.46	27.98	21.18	14.93	9.59	6.66

<b>TORQ(FL)#FT</b>	36.99	<b>TORQ(LR)%FL</b>	226.64	<b>TORQ(BD)%FL</b>	268.62
<b>AMPS(LR)</b>	173.61	<b>PF AT START</b>	0.39		

This motor is capable of two cold or one hot start with a maximum connected load inertia of 79 Lb-Ft Sq (3.33 Kg-meter Sq)at 100% voltage, where the load torque varies with the square of the speed. Acceleration time with maximum inertia and the above load type is 18 seconds. Safe stall time at 100% voltage is 40 seconds cold, 22 seconds hot. Rotor inertia is 2.11 Lb-Ft Sq (0.09 Kg-meter Sq).

<b>Open Circuit A-C:</b>	0.793	<b>Short Circuit D-C:</b>	0.013
<b>Short Circuit A-C:</b>	0.027	<b>X/R Ratio:</b>	4.793
<b>Stator Slots:</b>	48	<b>Rotor Slots:</b>	38

**Speed Torque Current Curve (First Connection, First Speed)**

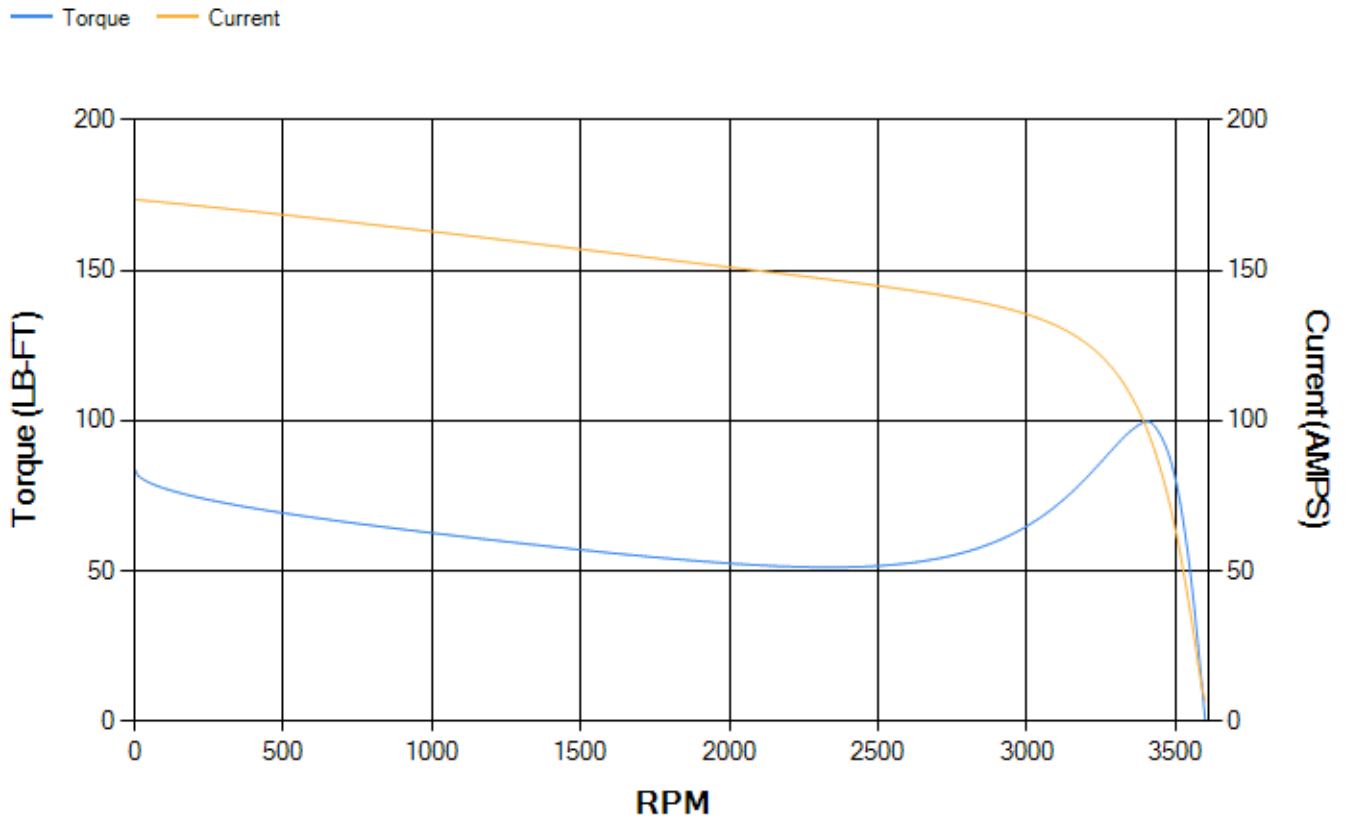

Marks:

NOTE 1: CONDUIT BOX MAY BE ASSEMBLED WITH ENTRANCE UP, DOWN OR TO EITHER SIDE.  
 NOTE 2: FIT ASSEMBLY AS SHOWN.  
 NOTE 3: ALL DIMENSIONS ARE IN INCHES, BRACKETED DIMENSIONS ARE IN METRIC (MILLIMETERS).

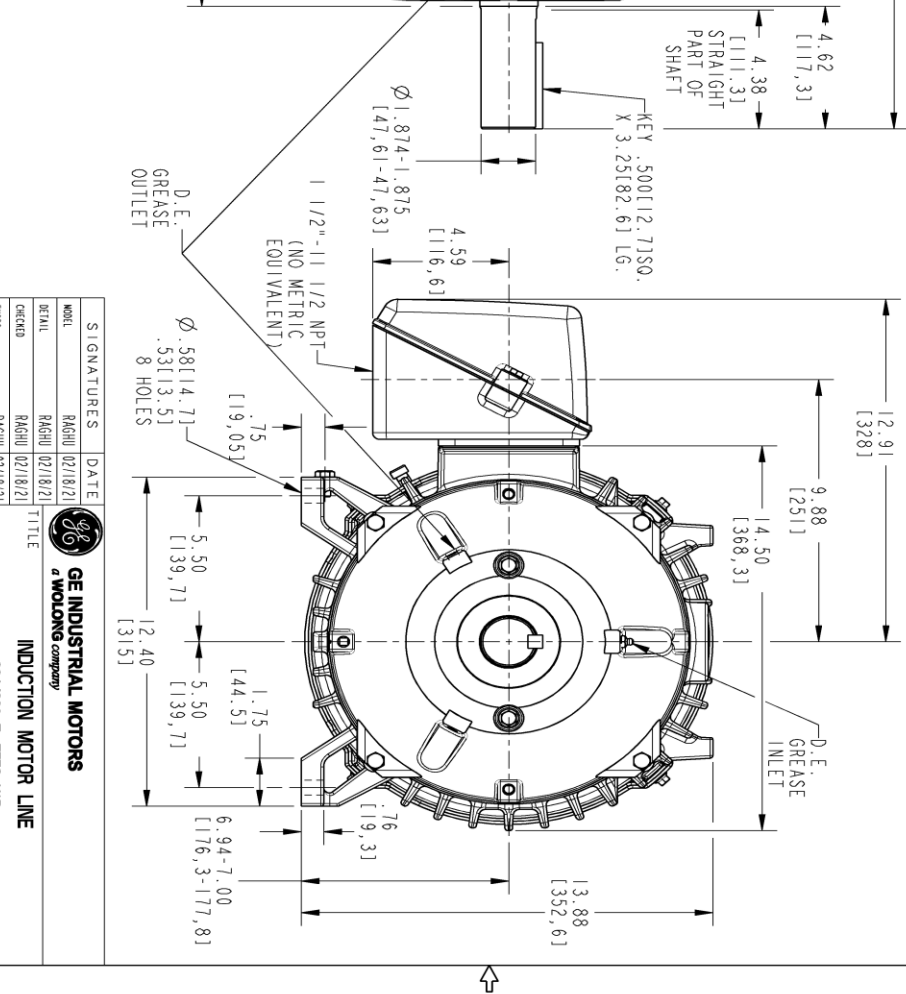
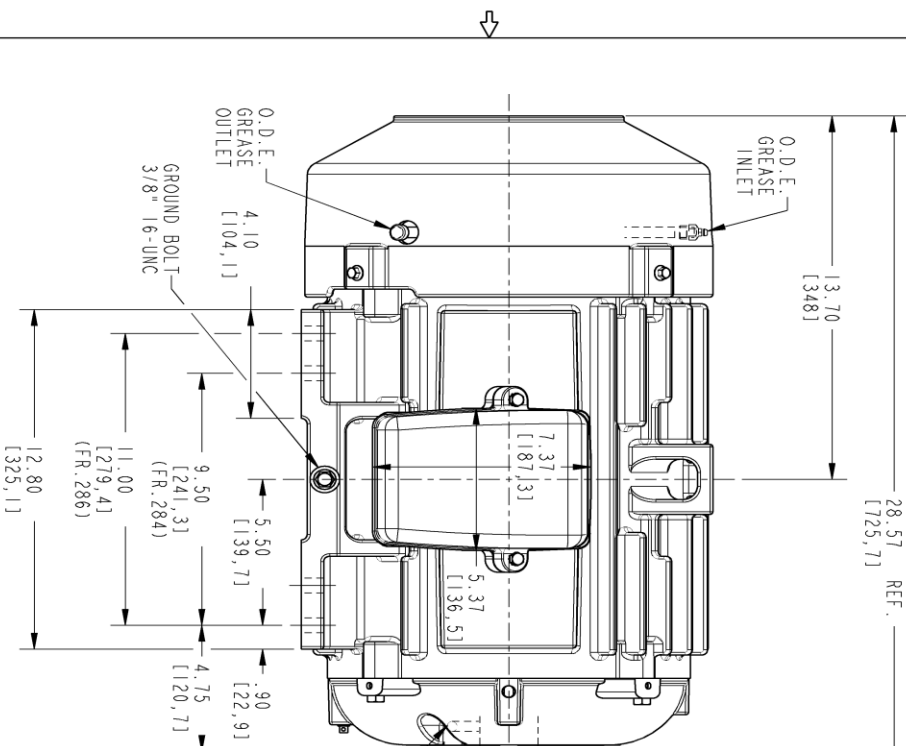

PROPRIETARY INFORMATION  
 © COPYRIGHT 2018 Wolog Electric America LLC AND/OR ITS AFFILIATES  
 All rights reserved. This document and the information it contains is the property of Wolog Electric America LLC and/or its affiliates. It has been provided solely for transmission and use of the equipment and any of the components thereof. It is strictly prohibited to copy, reproduce, or disseminate this information in any form or by any means without the express written permission of Wolog Electric America LLC.

REV.	DESCRIPTION	DATE	APPROVED

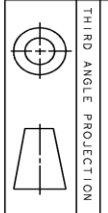

SIGNATURES	DATE
MODEL	02/18/21
DETAIL	02/18/21
CHECKED	02/18/21
ENGR	02/18/21
WEG	
QUALITY	
ISSUED	02/18/21
SOLID MODEL	4002B5828PAP5943

**GE INDUSTRIAL MOTORS**  
 a Wolog company  
**INDUCTION MOTOR LINE**  
 284/286 T, TEFC XSD  
 C/BOX 137 CUIN GROUND PAD  
**4002B5828PAP5943**  
 SCALE: 0.250 REF. No.: 4002B5828PAP5311

REV	DESCRIPTION
000	

SHEET DRAWING NO. 4002B5828PAP5943 000  
 SHEET 1 OF 1

Marks:

**Connection Diagram**  
**GEM2034E-FIG9**



End shield Assembly		
Part Description	DE Side Part#	ODE Side Part#
End Shield	4004D5284PB1	4004D5284SE1
Bearing	235A2508EC01	235A2508EC01
Slinger/Inproseal	149C4399G03	149C4399G03

Fan & Fan Cover Assembly	
Part Description	Part#
Fan	159C6704G02
Fan Cover	4003C5789PA1

Conduit & Accessories Box Assembly	
Part Description	Part#
Conduit Box	4002B5728PA-G01

Mechanical Accessories	
Part Description	Part#
Brake	
Tachometer	

