



**GE INDUSTRIAL MOTORS**  
a **WOLONG** company

# Product Technical Information

June 25, 2020

Data shown is for the current revision model #. Ensure your nameplate model # matches.

<b>Model Number:</b>	<b>5KS324XAA218C</b>
<b>Catalog Number:</b>	<b>M9389</b>
<b>Instruction Manual:</b>	GEI-56128
<b>Connection Diagram:</b>	GEM2034E-FIG7
<b>Outline Drawing:</b>	239C6000RK

## Accessory Connection Diagrams

<b>Bearing Thermocouple:</b>	None	<b>Heater:</b>	None
<b>RTD:</b>	None	<b>Thermistor:</b>	None
<b>Thermostat:</b>	None	<b>Winding Thermocouple:</b>	None
<b>Bearing RTD:</b>	None		

## Table of Contents

Specification	01
Performance Characteristics	02
Outline Drawing	03
Connection Drawing(s)	04
Spare parts	05

Marks:

<b>MODEL NUMBER:</b>	<b>5KS324XAA218C</b>	<b>Estimated Weight:</b>	670 Lbs
<b>Outline Drawing:</b>	239C6000RK	<b>Time Rating:</b>	CONT
<b>Connection Diagram:</b>	GEM2034E-FIG7	<b>Enclosure:</b>	TEFC
<b>Instruction Book:</b>	GEI-56128	<b>Encl Construction:</b>	841
<b>Design Code:</b>	32BD1182A	<b>Ambient Max(°C):</b>	40
<b>Type:</b>	KS	<b>Alt Ambient Max(°C):</b>	--
<b>Frame:</b>	324TS	<b>Insulation Class:</b>	H
<b>Phases:</b>	3	<b>NEMA Design:</b>	B
<b>Poles:</b>	4	<b>Nominal Efficiency:</b>	94.1 %
<b>Output Power:</b>	40HP 29.6KW	<b>Guaranteed Efficiency:</b>	93.6 %
<b>RPM:</b>	1780	<b>3/4 Load Efficiency:</b>	94.4 %
<b>Voltage:</b>	460	<b>KVA Code:</b>	G
<b>Hertz:</b>	60	<b>Max KVAR:</b>	15.2
<b>Amps - FL:</b>	49.7	<b>Power Factor:</b>	80.0
<b>Service Factor:</b>	1.15	<b>Bearing - DE:</b>	6312ZC3
<b>Alt Service Factor:</b>	--	<b>Bearing - ODE:</b>	6312ZC3

Enclosure is Totally Enclosed Fan-Cooled

---

Stamped Nameplate Notes:

IEEE-STD-841-2009

DE BRG 60BC03JP30, ODE BRG 60BC03JP30

STAMP NP249A5564P051 AS BELOW:

MODEL:5KS324XAA218C S/N: XXX

CSA CERTIFIED CSA09.2216219 FOR EX NA IIC 200 C GC

CL 1 ZONE2 AEX NA IIC 200C;CL 1 DIV2 GRP ABCD 200C

IN -25C <= AMB <= 40C, 1.0 SF ON SINE-WAVE PWR

SURF TEMP 230C AT 1.15SF ON SINE-WAVE PWR

OR 200 C VT OR 230 C CT OR 200 C CHP PWM CONTROL

ALTERNATE RATING FOR PWM CONTROL 1.0SF 40C AMB

VT 0-60 HZ, CT 3-60 HZ, CHP 60-90 HZ.



**Additional Information:**

4P - TS EXTN  
PAINTED FRAME ID & SHAFT,  
FAN COVER INSIDE & ODE E/S OUTSIDE  
346 CU IN - 3.00" NPT  
INPRO SEAL BOTH ENDS  
OIL RESISTANT SLEEVING ON LEADS  
.0015" TIR SHAFT RUNOUT  
ROUTINE TEST REPORT AND 5 POINT VIBRATION TEST  
REPORT INCLUDED IN C/B  
COPPER WASHER UNDER HEADS OF BEARING CAP BOLTS,  
APPLY TITE-SEAL (A50CD427A) ON BEARING CAP SCREWS,  
RABBETS AND PLUG THREADS.  
GROUND PAD  
F1 MOUNTING



**Performance Characteristics**

1st Winding 1st Connection

**Design: 32BD1182A**

**Marks:**

LOAD %	125.0	115.0	100.0	75.0	50.0	25.0	0.0
% EFF	93.44	93.73	94.29	94.38	93.95	91	0.00
% PF	82.18	81.61	80.15	75.28	64.7	42.44	3.55
AMPS	60.94	56.28	49.43	39.52	30.79	24.24	21.17

<b>TORQ(FL)#FT</b>	118.11	<b>TORQ(LR)%FL</b>	162.85	<b>TORQ(BD)%FL</b>	242.14
<b>AMPS(LR)</b>	267.59	<b>PF AT START</b>	0.33		

This motor is capable of two cold or one hot start with a maximum connected load inertia of 952 Lb-Ft Sq (40.08 Kg-meter Sq)at 100% voltage, where the load torque varies with the square of the speed. Acceleration time with maximum inertia and the above load type is 40 seconds. Safe stall time at 100% voltage is 88 seconds cold, 47 seconds hot. Rotor inertia is 6.94 Lb-Ft Sq (0.29 Kg-meter Sq).

<b>Open Circuit A-C:</b>	0.479	<b>Short Circuit D-C:</b>	0.022
<b>Short Circuit A-C:</b>	0.032	<b>X/R Ratio:</b>	8.428
<b>Stator Slots:</b>	48	<b>Rotor Slots:</b>	38

**Speed Torque Current Curve (First Connection, First Speed)**

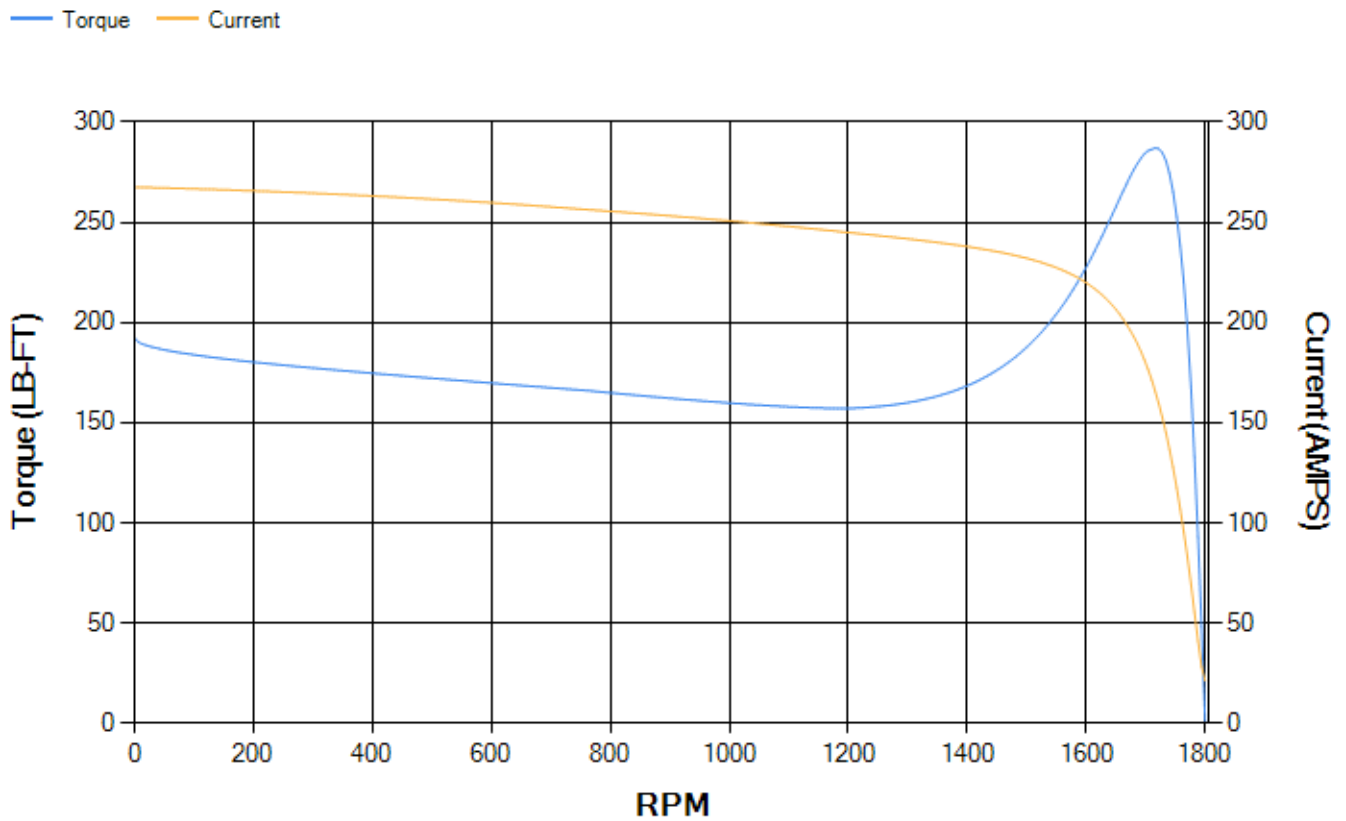

Marks:

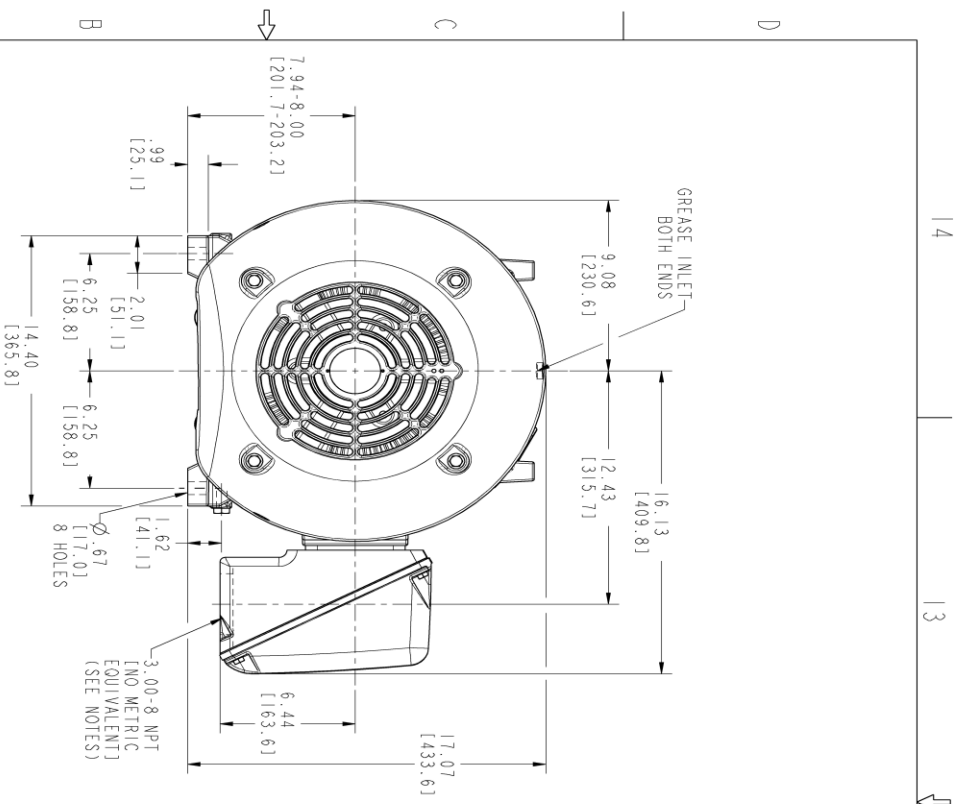

NOTES :

1. CONDUIT BOX MAY BE PLACED WITH THE ENTRANCE DOWN, UP OR ON EITHER SIDE.
2. F-1 ASM AS SHOWN.
3. BRACKETED DIMENSIONS ARE METRIC (MILLIMETERS).
4. TOLERANCE ON PERMISSIBLE SHAFT EXTENSION RUNOUT IS .0015 T.I.R.

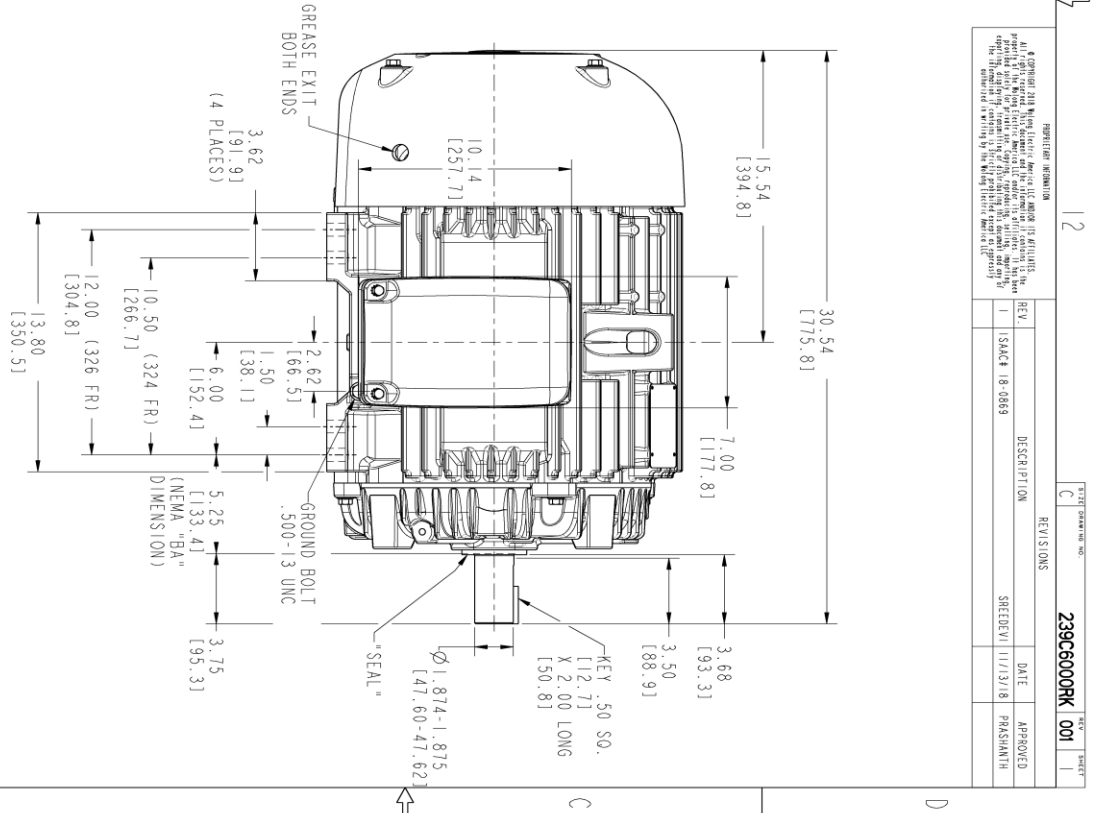

REGISTRATION INFORMATION

© COPYRIGHT 2018 GE Industrial America LLC AND/OR ITS AFFILIATES. ALL RIGHTS RESERVED. THIS DOCUMENT IS UNCLASSIFIED AND IS NOT A CONTROLLED DOCUMENT. IT IS THE PROPERTY OF GE INDUSTRIAL AMERICA LLC AND/OR ITS AFFILIATES. IT IS TO BE USED ONLY FOR THE PROJECT AND PURPOSE SPECIFIED IN THE TITLE. IT IS NOT TO BE REPRODUCED, COPIED, OR TRANSMITTED IN ANY FORM OR BY ANY MEANS, ELECTRONIC OR MECHANICAL, INCLUDING PHOTOCOPYING, RECORDING, OR BY ANY INFORMATION STORAGE AND RETRIEVAL SYSTEM, WITHOUT THE WRITTEN PERMISSION OF GE INDUSTRIAL AMERICA LLC AND/OR ITS AFFILIATES.

REV.	DESCRIPTION	DATE	APPROVED
1	ISSUE 18-0869	11/13/18	PRASHANTH

REV: 1  
DESCRIPTION: 239C6000RK 001  
DATE: 11/13/18  
APPROVED: PRASHANTH

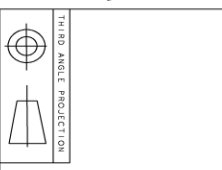

SIGNATURES	DATE	TITLE
MODEL: TEJASNI	06/19/15	<p><b>GE INDUSTRIAL MOTORS</b> a WOLONG company</p> <p><b>OUTLINE</b> 324/326 TS TFC XSD 841 346 CU IN CONDUIT BOX</p> <p><b>239C6000RK</b></p>
CHECKED: KARTHICK	06/19/15	
DESIGN: VENKAT	06/19/15	
DATE: 06/19/15		
ISSUED: TEJASNI	06/19/15	SIZE: DRAWING: C
SCALE: 0.250		REF. NO: 239C6000AK
SHEET: 001		REV: 001
SHEET 1 OF 1		

**Marks:**

**Connection Diagram**  
**GEM2034E-FIG7**



End shield Assembly		
Part Description	DE Side Part#	ODE Side Part#
End Shield	115E4200AA1	115E4200LA1
Bearing	235A2509AS01	235A2509AS01
Slinger/Inproseal	235A4575GS2	235A4575GS2

Fan & Fan Cover Assembly	
Part Description	Part#
Fan	159C6900G04
Fan Cover	128D6800AA1

Conduit & Accessories Box Assembly	
Part Description	Part#
Conduit Box	149C4429AA2

Mechanical Accessories	
Part Description	Part#
Brake	
Tachometer	

