



**GE INDUSTRIAL MOTORS**  
a **WOLONG** company

# Product Technical Information

June 23, 2020

Data shown is for the current revision model #. Ensure your nameplate model # matches.

<b>Model Number:</b>	<b>5KS145XAA145C</b>
<b>Catalog Number:</b>	<b>M9405</b>
<b>Instruction Manual:</b>	GEI-56128
<b>Connection Diagram:</b>	GEM2034E-FIG7
<b>Outline Drawing:</b>	4002B5814PDP5310

## Accessory Connection Diagrams

<b>Bearing Thermocouple:</b>	None	<b>Heater:</b>	None
<b>RTD:</b>	None	<b>Thermistor:</b>	None
<b>Thermostat:</b>	None	<b>Winding Thermocouple:</b>	None
<b>Bearing RTD:</b>	None		

## Table of Contents

Specification	01
Performance Characteristics	02
Outline Drawing	03
Connection Drawing(s)	04
Spare parts	05

Marks:

<b>MODEL NUMBER:</b>	<b>5KS145XAA145C</b>	<b>Estimated Weight:</b>	50 Lbs
<b>Outline Drawing:</b>	4002B5814PDP5310	<b>Time Rating:</b>	CONT
<b>Connection Diagram:</b>	GEM2034E-FIG7	<b>Enclosure:</b>	TEFC
<b>Instruction Book:</b>	GEI-56128	<b>Encl Construction:</b>	841
<b>Design Code:</b>	14BD0070A	<b>Ambient Max(°C):</b>	40
<b>Type:</b>	KS	<b>Alt Ambient Max(°C):</b>	--
<b>Frame:</b>	145TC	<b>Insulation Class:</b>	H
<b>Phases:</b>	3	<b>NEMA Design:</b>	B
<b>Poles:</b>	2	<b>Nominal Efficiency:</b>	85.5 %
<b>Output Power:</b>	2HP 1.5KW	<b>Guaranteed Efficiency:</b>	84.0 %
<b>RPM:</b>	3515	<b>3/4 Load Efficiency:</b>	85.4 %
<b>Voltage:</b>	460	<b>KVA Code:</b>	L
<b>Hertz:</b>	60	<b>Max KVAR:</b>	0.8
<b>Amps - FL:</b>	2.7	<b>Power Factor:</b>	81.0
<b>Service Factor:</b>	1.15	<b>Bearing - DE:</b>	6206ZC3
<b>Alt Service Factor:</b>	--	<b>Bearing - ODE:</b>	6205ZC3

Enclosure is Totally Enclosed Fan-Cooled

---

Stamped Nameplate Notes:

IEEE-STD-841-2009  
 DE BRG 30BC02JP30 ODE BRG 25BC02JP30  
 STAMP NP249A5564P051 AS BELOW:  
 MODEL:5KS145XAA145C S/N: XXX  
 CSA CERTIFIED CSA09.2216219 FOR EX NA IIC 200 C GC  
 CL1 ZONE2 AEXNAIIC 200C FOR CL1DIV2 GRP ABCD 200C  
 IN -25C <= AMB <= 40C, 1.0SF ON SINE-WAVE PWR  
 SURF TEMP 200 C AT 1.15 SF ON SINE-WAVE PWR  
 OR 200 C VT OR 200 C CT OR 200 C CHP PWM CONTROL  
 ALTERNATE RATING FOR PWM CONTROL 1.0SF 40C AMB  
 VT 0-60 HZ, CT 3-60 HZ, CHP 60-90 HZ.

Additional Information:

2P - T EXTN  
 C/BOX 30 CU IN-0.75 NPT  
 "C" FACE AT DE ENDSHIELD ROUND FRAME  
 VERTICAL MOUNT SHAFT DOWN WITH DRIPCOVER  
 PAINTED FRAME ID & SHAFT,  
 FAN COVER INSIDE & ODE E/S OUTSIDE  
 ROUTINE AND 5 POINT VIBRATION TESTS INCL IN C/BOX  
 INPRO SEAL BOTH ENDS  
 BURNDY SERVIT POST ON FRAME  
 SHAFT RUNOUT LIMIT .001" TIR  
 COPPER WASHER UNDER HEADS OF BEARING CAP BOLTS  
 APPLY TITE-SEAL (A50CD427A) ON BEARING CAP SCREWS, RABBETS,  
 AND PLUG THREADS  
 OIL RESISTANT SLEEVING ON LEADS





**Performance Characteristics**

1st Winding 1st Connection

**Design: 14BD0070A**

**Marks:**

LOAD %	125.0	115.0	100.0	75.0	50.0	25.0	0.0
% EFF	84.43	84.88	85.56	85.37	83.45	75.41	0.00
% PF	84.43	83.22	84.44	74.24	62.39	41.49	11.11
AMPS	3.28	3.05	2.57	2.22	1.8	1.5	1.15

<b>TORQ(FL)#FT</b>	2.99	<b>TORQ(LR)%FL</b>	317.86	<b>TORQ(BD)%FL</b>	416.35
<b>AMPS(LR)</b>	22.51	<b>PF AT START</b>	0.55		

This motor is capable of two cold or one hot start with a maximum connected load inertia of 15 Lb-Ft Sq (0.63 Kg-meter Sq)at 100% voltage, where the load torque varies with the square of the speed. Acceleration time with maximum inertia and the above load type is 22 seconds. Safe stall time at 100% voltage is 49 seconds cold, 34 seconds hot. Rotor inertia is 0.04 Lb-Ft Sq (0 Kg-meter Sq).

<b>Open Circuit A-C:</b>	0.242	<b>Short Circuit D-C:</b>	0.005
<b>Short Circuit A-C:</b>	0.009	<b>X/R Ratio:</b>	1.88
<b>Stator Slots:</b>	24	<b>Rotor Slots:</b>	34

**Speed Torque Current Curve (First Connection, First Speed)**

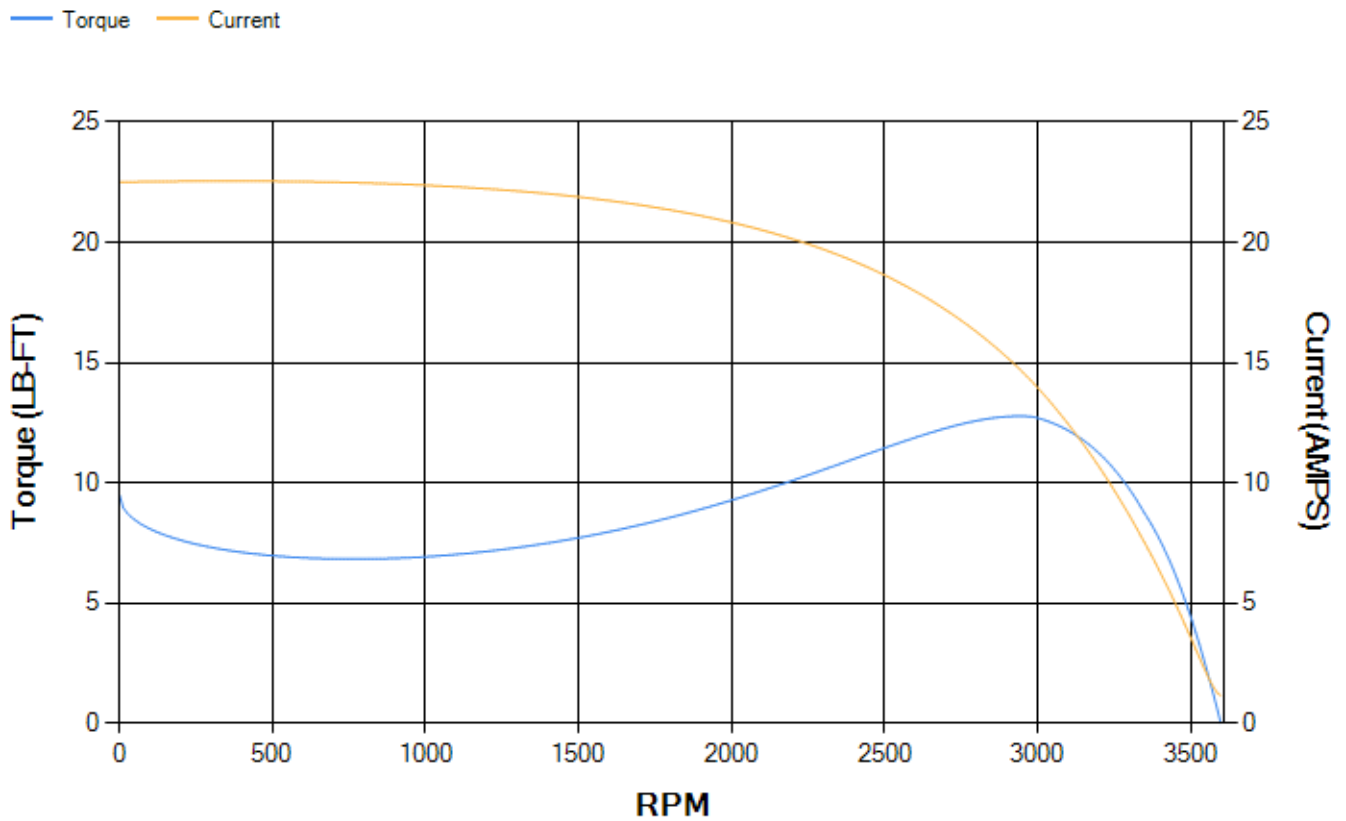

Marks:

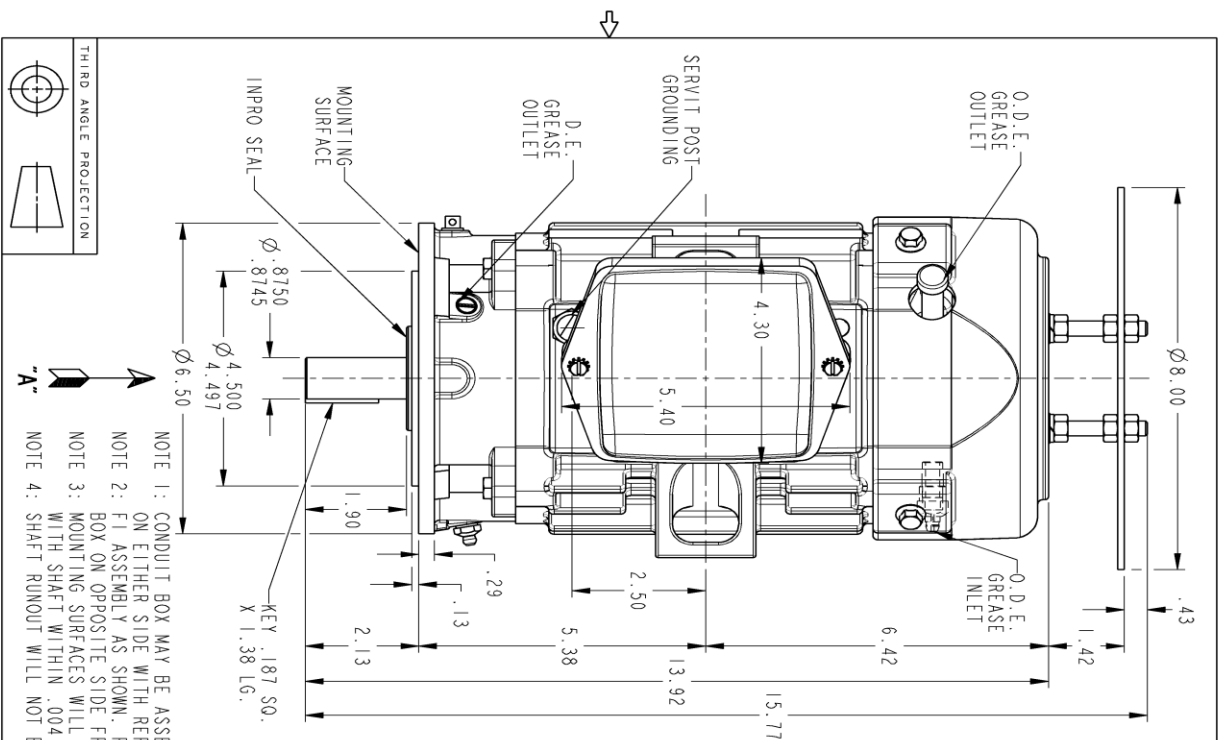

PROPRIETARY INFORMATION  
 © COPYRIGHT 2018 Wolong Electric America LLC AND/OR ITS AFFILIATES.  
 All rights reserved. This document and the information it contains is the property of  
 the Wolong Electric America LLC and/or its affiliates. It has been provided solely for  
 transmission to the recipient for the specific purpose of the information provided.  
 No other use, copying, or distribution of this document or its contents is permitted  
 without the express written consent of the sender. Any other use, copying, or  
 distribution of this document or its contents is strictly prohibited except as expressly authorized in writing by  
 the Wolong Electric America LLC.

NOTE 1: CONDUIT BOX MAY BE ASSEMBLED WITH ENTRANCE  
 ON EITHER SIDE WITH REFERENCE TO CURRENT LOCATION.  
 NOTE 2: F1 ASSEMBLY AS SHOWN. F2 ASSEMBLY CONDUIT  
 BOX ON OPPOSITE SIDE FROM SHOWN LOCATION.  
 NOTE 3: MOUNTING SURFACES WILL BE SQUARE AND CONCENTRIC  
 WITH SHAFT WITHIN .004 T.I.R.  
 NOTE 4: SHAFT RUNOUT WILL NOT EXCEED .001 T.I.R.

SIGNATURES	DATE
DESIGNER: ADINARAYANA	05/10/20
ENGINEER: N. PRASAD	05/10/20
ISSUED: N. PRASAD	05/10/20
QUALITY: B	

**GE INDUSTRIAL MOTORS**  
 a wolong company  
**INDUCTION MOTOR OUTLINE**  
 IEEE-941 SPEC WITH CONDUIT BOX & DRIP COVER  
 FAN- 140TC TERC "C" FACE (450° RABBET), FOOTLESS  
**4002B5814PDP5310**  
 SCALE: 0.450 REF. No.:  
 SHEET 1 OF 1

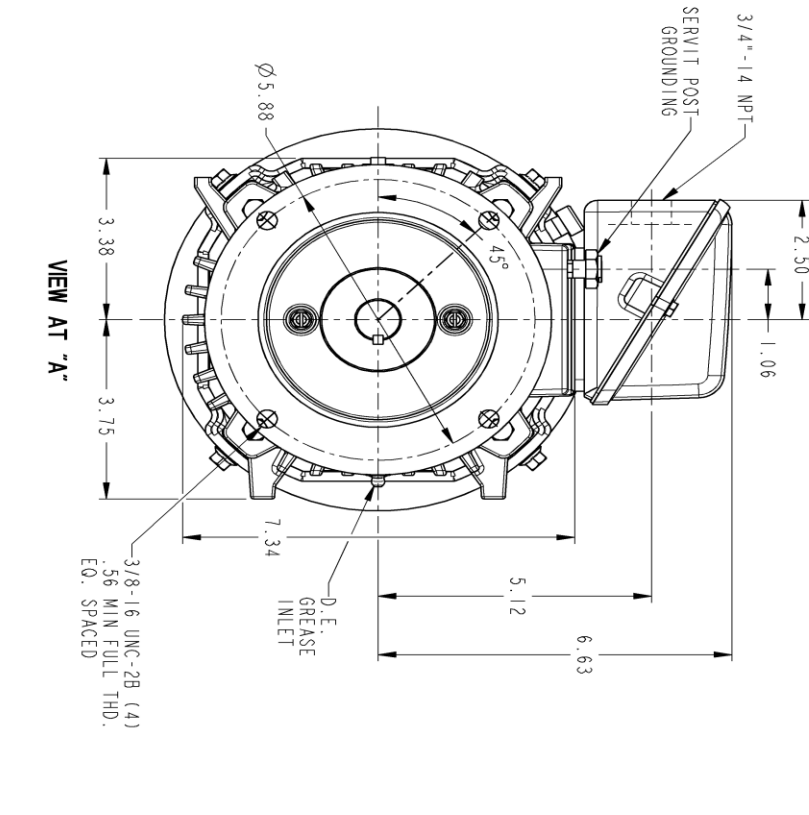

REV.	DESCRIPTION	DATE	APPROVED
1	ISAC# 12-0115	02/01/12	P1YUSH
2	ISAC# 18-0869	10/23/18	PRASHANTH

SIZE: DRAWING NO. **4002B5814PDP5310** REV. **002** SHEET **1**  
 REVISIONS

Marks:

**Connection Diagram**  
**GEM2034E-FIG7**



End shield Assembly		
Part Description	DE Side Part#	ODE Side Part#
End Shield	4004D5289PB1	4004D5280SG1
Bearing	235A2502AM01	235A2500AF01
Slinger/Inproseal	4002B5914AM1	4002B5914AG1

Fan & Fan Cover Assembly	
Part Description	Part#
Fan	4001A5914AM-G01
Fan Cover	4003C5514BN-G01

Conduit & Accessories Box Assembly	
Part Description	Part#
Conduit Box	4002B5718PA-G01

Mechanical Accessories	
Part Description	Part#
Brake	
Tachometer	

