



GE INDUSTRIAL MOTORS
a **WOLONG** company

Product Technical Information

June 23, 2020

Data shown is for the current revision model #. Ensure your nameplate model # matches.

Model Number:	5KS182XAA2004B
Catalog Number:	M9409
Instruction Manual:	GEI-56128
Connection Diagram:	GEM2034E-FIG1
Outline Drawing:	4002B5818PDP5310

Accessory Connection Diagrams

Bearing Thermocouple:	None	Heater:	None
RTD:	None	Thermistor:	None
Thermostat:	None	Winding Thermocouple:	None
Bearing RTD:	None		

Table of Contents

Specification	01
Performance Characteristics	02
Outline Drawing	03
Connection Drawing(s)	04
Spare parts	05

Marks:

MODEL NUMBER:	5KS182XAA2004B	Estimated Weight:	76 Lbs
Outline Drawing:	4002B5818PDP5310	Time Rating:	CONT
Connection Diagram:	GEM2034E-FIG1	Enclosure:	TEFC
Instruction Book:	GEI-56128	Encl Construction:	841
Design Code:	18BD1124AA	Ambient Max(°C):	40
Type:	KS	Alt Ambient Max(°C):	--
Frame:	182TC	Insulation Class:	H
Phases:	3	NEMA Design:	B
Poles:	4	Nominal Efficiency:	89.5 %
Output Power:	3HP 2.2KW	Guaranteed Efficiency:	88.5 %
RPM:	1765	3/4 Load Efficiency:	89.7 %
Voltage:	460	KVA Code:	K
Hertz:	60	Max KVAR:	1.3
Amps - FL:	4.0	Power Factor:	78.5
Service Factor:	1.15	Bearing - DE:	6307ZC3
Alt Service Factor:	--	Bearing - ODE:	6206ZC3

Enclosure is Totally Enclosed Fan-Cooled

Stamped Nameplate Notes:

IEEE-STD-841-2009
 DE BRG 35BC03JP30 ODE BRG 30BC02JP30
 STAMP NP249A5564P051 AS BELOW:
 MODEL:5KS182XAA2004B S/N: XXX
 CSA CERTIFIED CSA09.2216219 FOR EX NA IIC 200 C GC
 CL1 ZONE2 AEXNAIIC 200C FOR CL1DIV2 GRP ABCD 200C
 IN -25C <= AMB <= 40C, 1.0 SF ON SINE-WAVE PWR
 SURF TEMP 200 C AT 1.15 SF ON SINE-WAVE PWR
 OR 200 C VT OR 200 C CT OR 200 C CHP PWM CONTROL
 ALTERNATE RATING FOR PWM CONTROL 1.0 SF 40 C AMB
 VT 0-60 HZ, CT 3-60 HZ, CHP 60-90 HZ.

Additional Information:

4P - T EXTN
 C/BOX 55 CU IN-1.00 NPT
 "C" FACE AT DE ENDSHIELD ROUND FRAME
 VERTICAL MOUNT SHAFT DOWN WITH DRIPCOVER
 PAINTED FRAME ID & SHAFT,
 FAN COVER INSIDE & ODE E/S OUTSIDE
 ROUTINE AND 5 POINT VIBRATION TESTS INCL IN C/BOX
 INPRO SEAL BOTH ENDS
 BURNDY SERVIT POST ON FRAME
 SHAFT RUNOUT LIMIT .001" TIR
 COPPER WASHER UNDER HEADS OF BEARING CAP BOLTS
 APPLY TITE-SEAL (A50CD427A) ON BEARING CAP SCREWS, RABBETS,
 AND PLUG THREADS
 OIL RESISTANT SLEEVING ON LEADS





Performance Characteristics

1st Winding 1st Connection

Design: 18BD1124AA

Marks:

LOAD %	125.0	115.0	100.0	75.0	50.0	25.0	0.0
% EFF	88.75	89.13	89.75	89.66	88.36	82.35	0.00
% PF	81.25	80.3	79.69	72.28	60.86	39.83	7.34
AMPS	4.87	4.51	3.93	3.25	2.61	2.14	1.82

TORQ(FL)#FT	8.93	TORQ(LR)%FL	247.74	TORQ(BD)%FL	333.6
AMPS(LR)	26.76	PF AT START	0.52		

This motor is capable of two cold or one hot start with a maximum connected load inertia of 160 Lb-Ft Sq (6.74 Kg-meter Sq)at 100% voltage, where the load torque varies with the square of the speed. Acceleration time with maximum inertia and the above load type is 47 seconds. Safe stall time at 100% voltage is 105 seconds cold, 83 seconds hot. Rotor inertia is 0.28 Lb-Ft Sq (0.01 Kg-meter Sq).

Open Circuit A-C:	0.27	Short Circuit D-C:	0.009
Short Circuit A-C:	0.014	X/R Ratio:	3.257
Stator Slots:	36	Rotor Slots:	28

Speed Torque Current Curve (First Connection, First Speed)

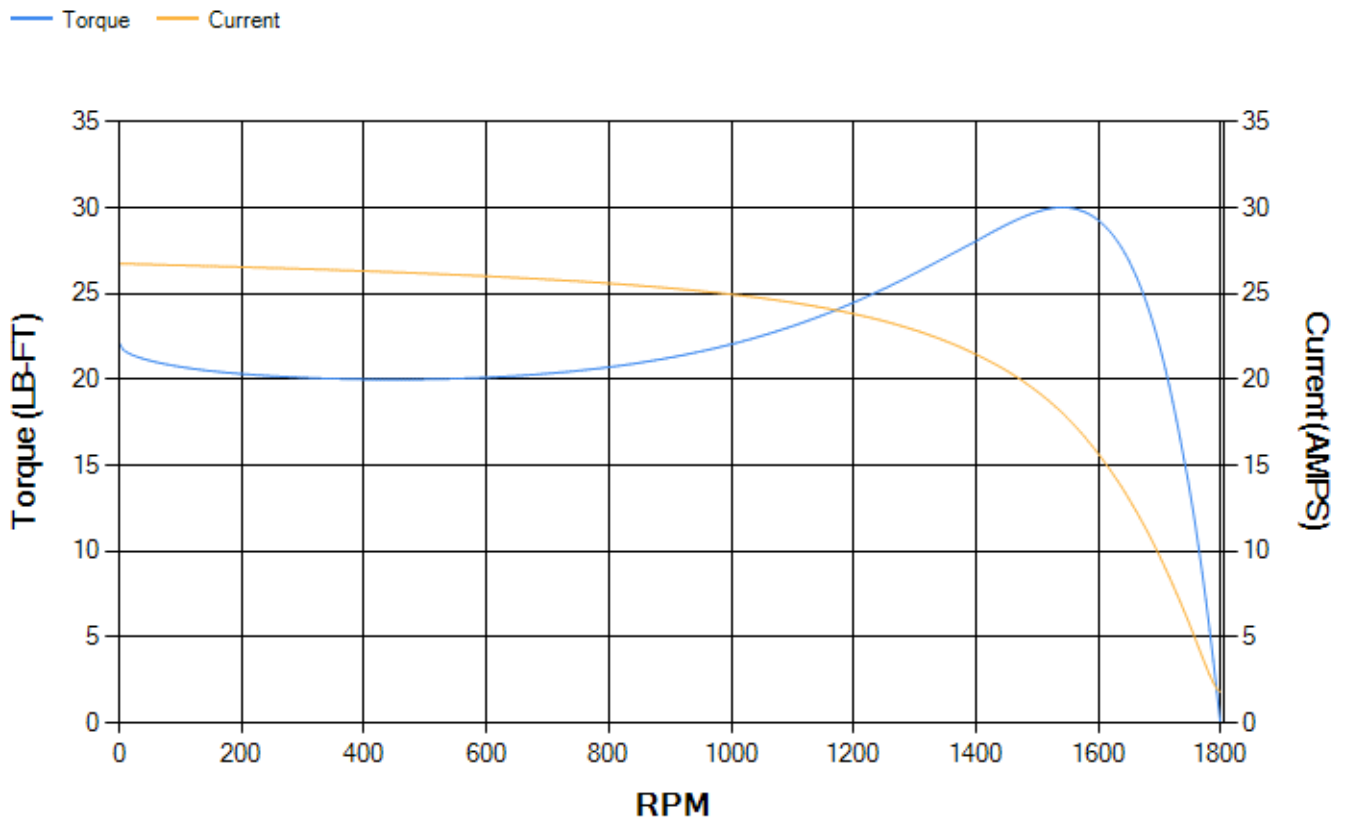

Marks:

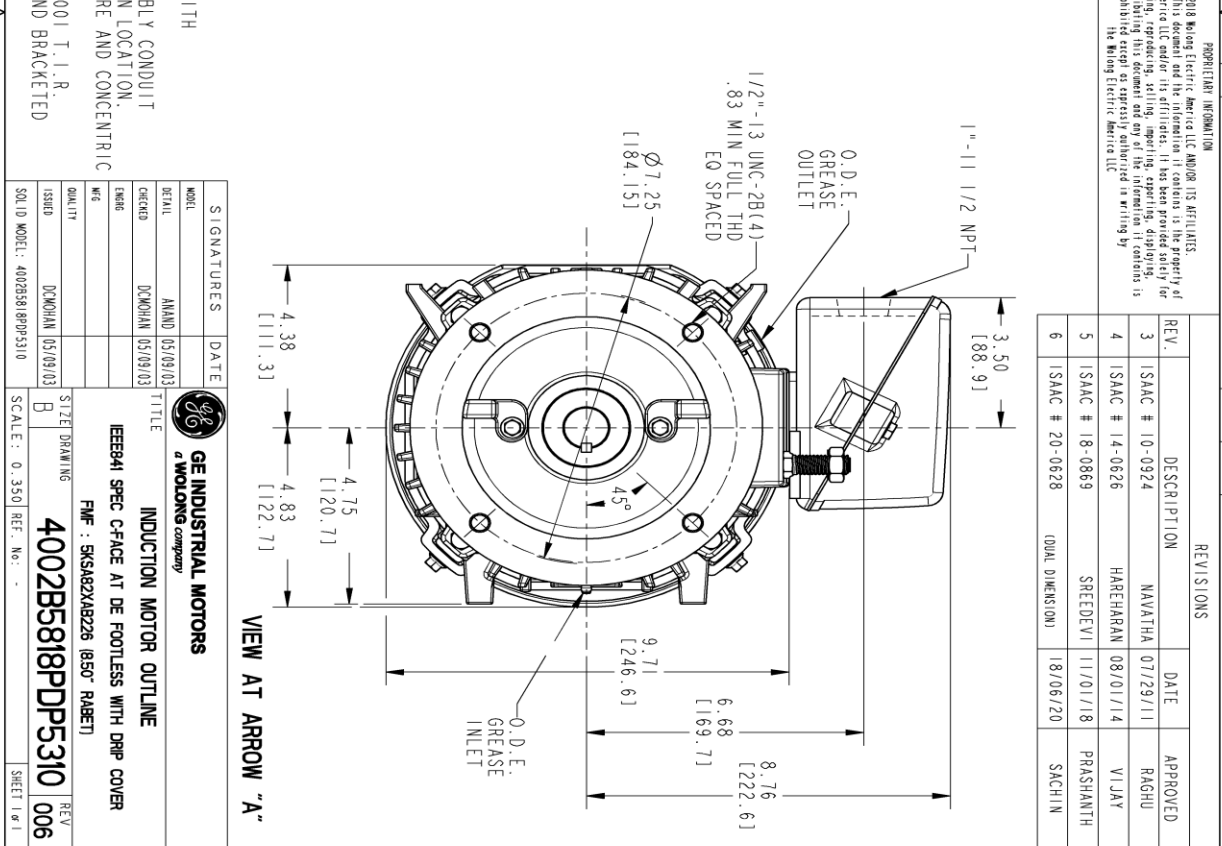
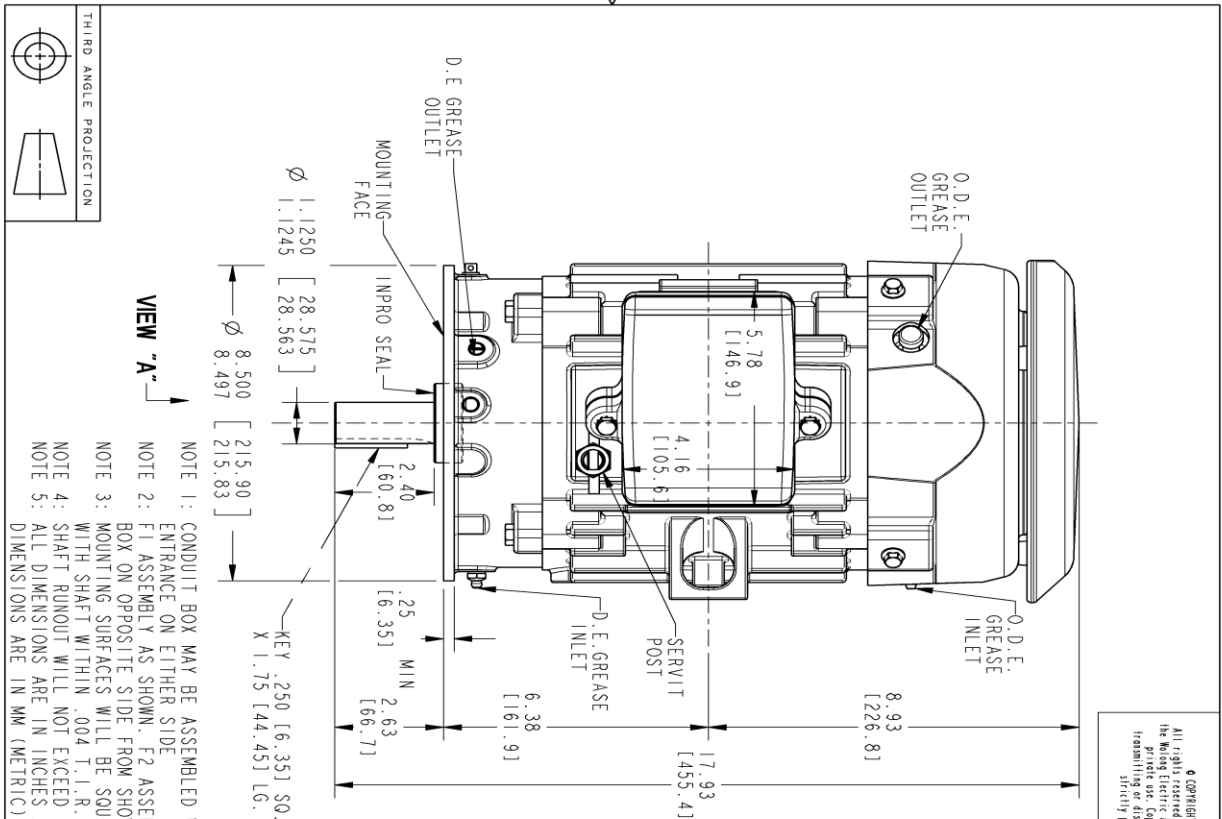

PROPRIETARY INFORMATION
 © COPYRIGHT 2018 Wolong Electric America LLC AND/OR ITS AFFILIATES
 All rights reserved. This document and the information it contains is the property of Wolong Electric America LLC and/or its affiliates. It has been provided solely for the use of the recipient and is not to be distributed, copied, or otherwise used without the express written consent of Wolong Electric America LLC. Any unauthorized use or disclosure is strictly prohibited except as expressly authorized in writing by Wolong Electric America LLC.

REV.	DESCRIPTION	DATE	APPROVED
3	ISAC # 10-0924	NAVATHA 07/29/11	RAGHU
4	ISAC # 14-0626	HAREHARAN 08/01/14	VIJAY
5	ISAC # 18-0869	SREEDevi 11/01/18	PRASHANTH
6	ISAC # 20-0628	(DUAL DIMENSION)	SACHIN

SIGNATURES	DATE
MANAD 05/09/03	
DCMOHAN 05/09/03	
DCMOHAN 05/09/03	

TITLE: INDUCTION MOTOR OUTLINE
 IEEB94 SPEC C/FACE AT DE FOOTLESS WITH DRP COVER
 FWF : 5KS182XAB226 (850° RABET)

SCALE: 0.350 REF. No. -

4002B5818PDP5310 006

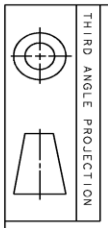

Marks:

Connection Diagram
GEM2034E-FIG1

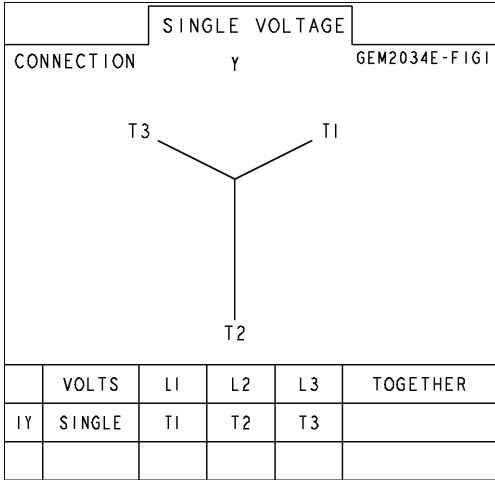

End shield Assembly		
Part Description	DE Side Part#	ODE Side Part#
End Shield	4004D5286PE1	4004D5281TG1
Bearing	235A2501AE01	235A2502AM01
Slinger/Inproseal	316A5384AJ1	4002B5914AG2

Fan & Fan Cover Assembly	
Part Description	Part#
Fan	346L620AN-G01
Fan Cover	4003C5518BN-G01

Conduit & Accessories Box Assembly	
Part Description	Part#
Conduit Box	4002B5721PA-G01

Mechanical Accessories	
Part Description	Part#
Brake	
Tachometer	

