



GE INDUSTRIAL MOTORS
a **WOLONG** company

Product Technical Information

February 19, 2021

Data shown is for the current revision model #. Ensure your nameplate model # matches.

Model Number:	5KS182XAA208D2
Catalog Number:	M9419
Instruction Manual:	GEI-56128
Connection Diagram:	GEM2034E-FIG1
Outline Drawing:	4002B5818PAP5311

Accessory Connection Diagrams

Bearing Thermocouple:	None	Heater:	None
RTD:	None	Thermistor:	None
Thermostat:	None	Winding Thermocouple:	None
Bearing RTD:	None		

Table of Contents

Specification	01
Performance Characteristics	02
Outline Drawing	03
Connection Drawing(s)	04
Spare parts	05

Marks:

MODEL NUMBER:	5KS182XAA208D2	Estimated Weight:	76 Lbs
Outline Drawing:	4002B5818PAP5311	Time Rating:	CONT
Connection Diagram:	GEM2034E-FIG1	Enclosure:	TEFC
Instruction Book:	GEI-56128	Encl Construction:	841
Design Code:	18BD1124AA	Ambient Max(°C):	40
Type:	KS	Alt Ambient Max(°C):	--
Frame:	182T	Insulation Class:	H
Phases:	3	NEMA Design:	B
Poles:	4	Nominal Efficiency:	89.5 %
Output Power:	3HP 2.2KW	Guaranteed Efficiency:	88.5 %
RPM:	1765	3/4 Load Efficiency:	--
Voltage:	460	KVA Code:	K
Hertz:	60	Max KVAR:	1.3
Amps - FL:	4.0	Power Factor:	78.5
Service Factor:	1.15	Bearing - DE:	6206ZC3
Alt Service Factor:	--	Bearing - ODE:	6206ZC3

Enclosure is Totally Enclosed Fan-Cooled

Stamped Nameplate Notes:

IEEE-STD-841-2009
 DE BRG 30BC02JP30 ODE BRG 30BC02JP30
 STAMP NP249A5564P051 AS BELOW:
 MODEL:5KS182XAA208D2 S/N: XXX
 CSA CERTIFIED CSA09.2216219 FOR EX NA IIC 200 C GC
 CL1 ZONE2 AEXNAIIC 200C FOR CL1DIV2 GRP ABCD 200C
 IN -25C <= AMB <= 40C, 1.0 SF ON SINE-WAVE PWR
 SURF TEMP 200 C AT 1.15 SF ON SINE-WAVE PWR
 OR 200 C VT OR 200 C CT OR 200 C CHP PWM CONTROL
 ALTERNATE RATING FOR PWM CONTROL 1.0 SF 40 C AMB
 VT 0-60 HZ, CT 3-60 HZ, CHP 60-90 HZ.



Additional Information:

4P - T EXTN
STANDARD FLOOR MOUNT
C/BOX 55 CU IN-1.00 NPT
F1 CONDUIT BOX MOUNTING
PAINTED FRAME ID & SHAFT,
FAN COVER INSIDE & ODE E/S OUTSIDE
ROUTINE AND 5 POINT VIBRATION TESTS INCL IN C/BOX
INPRO SEAL BOTH ENDS
GROUND SCREW ON FRAME
SHAFT RUNOUT LIMIT .001" TIR
COPPER WASHER UNDER HEADS OF BEARING CAP BOLTS
APPLY TITE-SEAL (A50CD427A) ON BEARING CAP SCREWS, RABBETS,
AND PLUG THREADS
OIL RESISTANT SLEEVING ON LEADS



Performance Characteristics

1st Winding 1st Connection

Design: 18BD1124AA

Marks:

LOAD %	125.0	115.0	100.0	75.0	50.0	25.0	0.0
% EFF	88.75	89.13	89.75	89.66	88.36	82.35	0.00
% PF	81.25	80.3	79.69	72.28	60.86	39.83	7.34
AMPS	4.87	4.51	3.93	3.25	2.61	2.14	1.82

TORQ(FL)#FT	8.93	TORQ(LR)%FL	247.74	TORQ(BD)%FL	333.6
AMPS(LR)	26.76	PF AT START	0.52		

This motor is capable of two cold or one hot start with a maximum connected load inertia of 160 Lb-Ft Sq (6.74 Kg-meter Sq)at 100% voltage, where the load torque varies with the square of the speed. Acceleration time with maximum inertia and the above load type is 47 seconds. Safe stall time at 100% voltage is 105 seconds cold, 83 seconds hot. Rotor inertia is 0.28 Lb-Ft Sq (0.01 Kg-meter Sq).

Open Circuit A-C:	0.27	Short Circuit D-C:	0.009
Short Circuit A-C:	0.014	X/R Ratio:	3.257
Stator Slots:	36	Rotor Slots:	28

Speed Torque Current Curve (First Connection, First Speed)

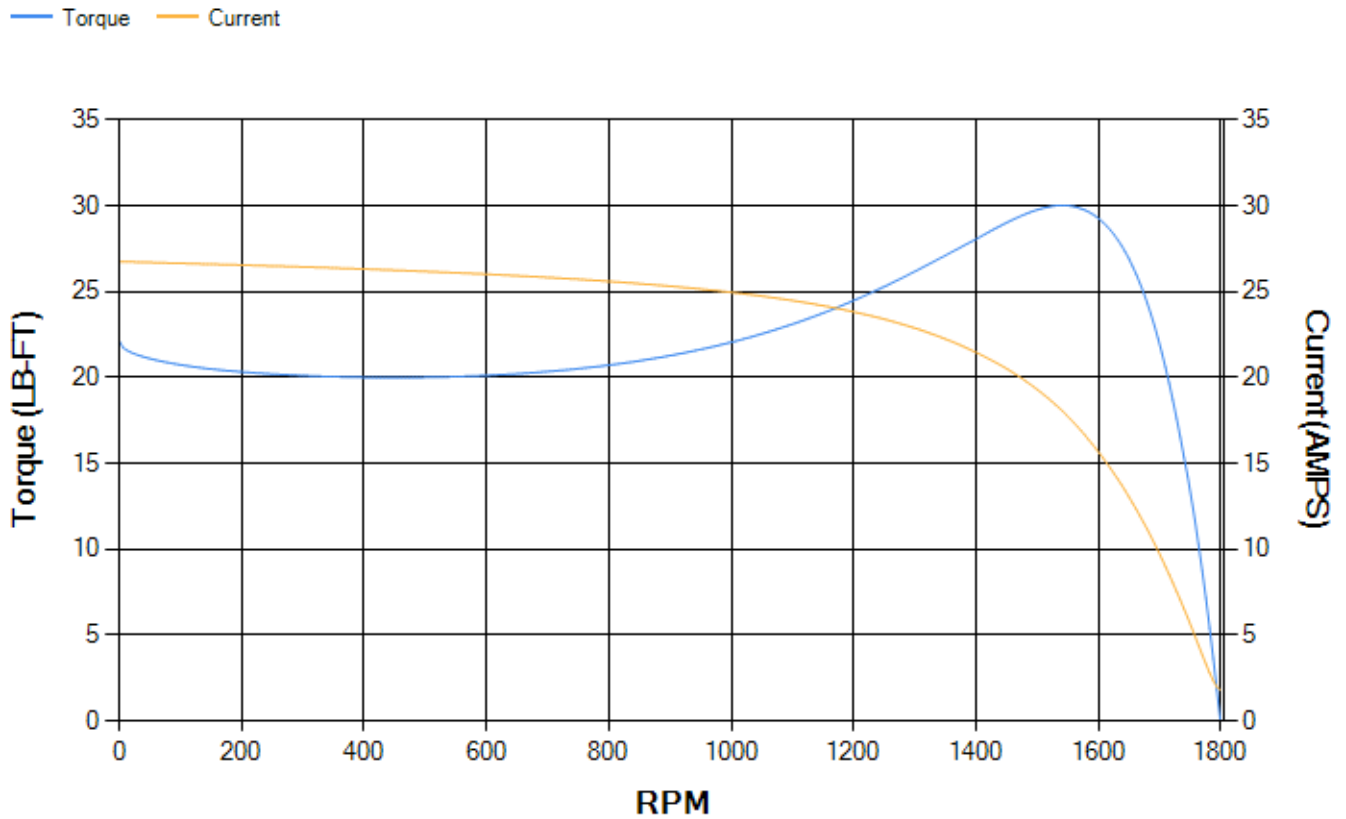

Marks:

NOTE 1: CONDUIT BOX MAY BE ASSEMBLED WITH ENTRANCE UP, DOWN OR TO EITHER SIDE.
 NOTE 2: F1 ASSEMBLY AS SHOWN. F2 ASSEMBLY CONDUIT BOX ON OPPOSITE SIDE FROM SHOWN LOCATION.
 NOTE 3: SHAFT RUNOUT WILL NOT EXCEED .001 T.I.R.
 NOTE 4: ALL DIMENSIONS ARE IN INCHES, BRACKETED DIMENSIONS ARE IN METRIC (MILLIMETERS).

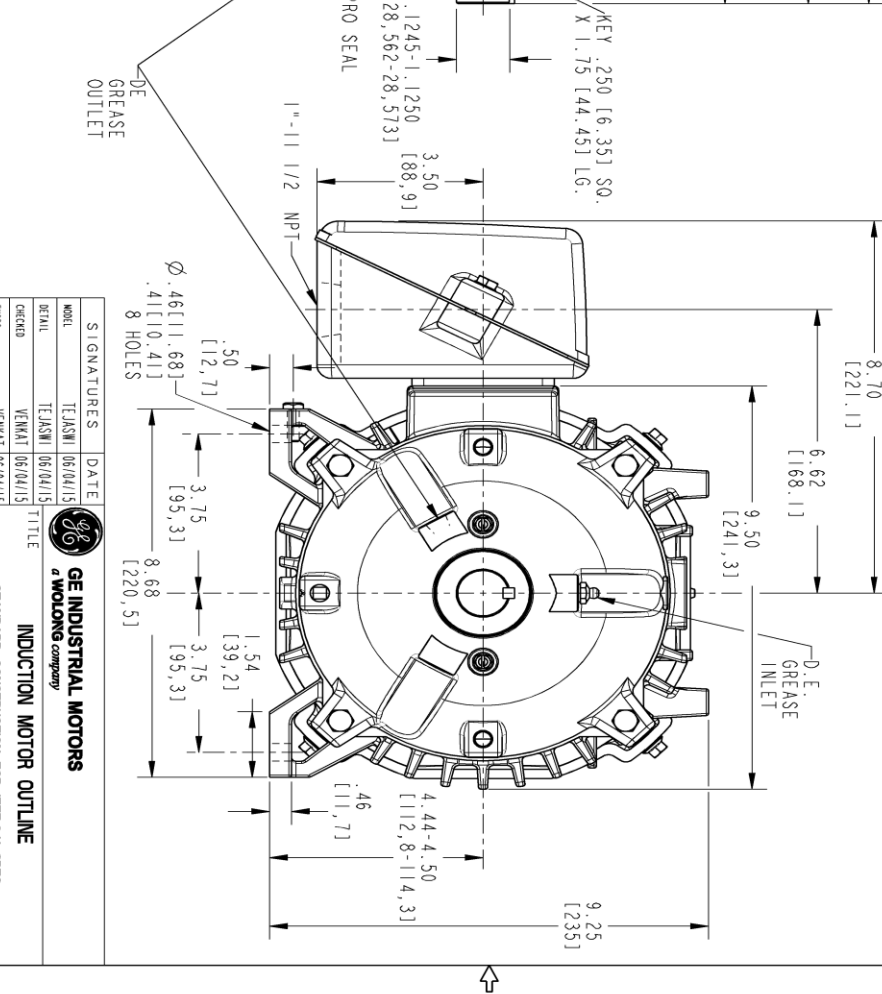
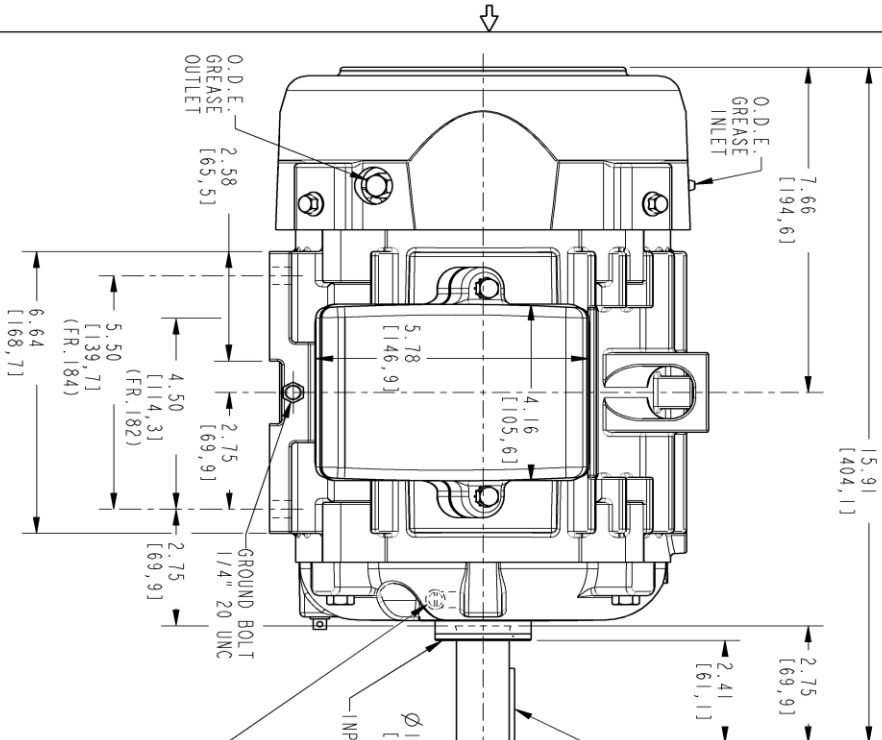

PROPRIETARY INFORMATION
 © COPYRIGHT 2018 Wolog Electric America LLC AND/OR ITS AFFILIATES.
 All rights reserved. This document and the information it contains is the property of Wolog Electric America LLC and/or its affiliates. It has been provided solely for transmission to the applicable recipient and any other use, reproduction, or disclosure is strictly prohibited except as expressly authorized in writing by Wolog Electric America LLC.

REV.	DESCRIPTION	DATE	APPROVED
1	ISAC #15-0731	07/17/15	KARTHIK
2	ISAC #16-0079	01/28/16	SRAVANTHI D
3	ISAC# 18-0869	10/28/18	PRAASHANTH

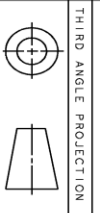

SIGNATURES	DATE	TITLE
TEJASNI	06/04/15	INDUCTION MOTOR OUTLINE STANDARD CONSTRUCTION FOR IEEE-941 SPEC FR182/94 T TERC
TEJASNI	06/04/15	
VENKAT	06/04/15	
VENKAT	06/04/15	
TEJASNI	06/04/15	

QUALITY CONTROL: TEJASNI 06/04/15
 ISSUED: B
 SCALE: 0.400 REF. No.: 4002B5818PAP5311
 SOLID MODEL: 4002B5818PAP5311



4002B5818PAP5311 003
 REV 1

Marks:

Connection Diagram
GEM2034E-FIG1



End shield Assembly		
Part Description	DE Side Part#	ODE Side Part#
End Shield	4004D5281PB1	4004D5281TG1
Bearing	235A2502AM01	235A2502AM01
Slinger/Inproseal	4002B5914AF2	4002B5914AG2

Fan & Fan Cover Assembly	
Part Description	Part#
Fan	346L620AN-G01
Fan Cover	4003C5786PA1

Conduit & Accessories Box Assembly	
Part Description	Part#
Conduit Box	4002B5721PA-G01

Mechanical Accessories	
Part Description	Part#
Brake	
Tachometer	

