



GE INDUSTRIAL MOTORS
a **WOLONG** company

Product Technical Information

June 24, 2020

Data shown is for the current revision model #. Ensure your nameplate model # matches.

Model Number:	5KS254XAA408D2
Catalog Number:	M9425
Instruction Manual:	GEI-56128
Connection Diagram:	GEM2034E-FIG7
Outline Drawing:	4002B5825PAP5311

Accessory Connection Diagrams

Bearing Thermocouple:	None	Heater:	None
RTD:	None	Thermistor:	None
Thermostat:	None	Winding Thermocouple:	None
Bearing RTD:	None		

Table of Contents

Specification	01
Performance Characteristics	02
Outline Drawing	03
Connection Drawing(s)	04
Spare parts	05

Marks:

MODEL NUMBER:	5KS254XAA408D2	Estimated Weight:	315 Lbs
Outline Drawing:	4002B5825PAP5311	Time Rating:	CONT
Connection Diagram:	GEM2034E-FIG7	Enclosure:	TEFC
Instruction Book:	GEI-56128	Encl Construction:	841
Design Code:	25BD4028A	Ambient Max(°C):	40
Type:	KS	Alt Ambient Max(°C):	--
Frame:	254T	Insulation Class:	H
Phases:	3	NEMA Design:	B
Poles:	8	Nominal Efficiency:	86.5 %
Output Power:	5HP 3.7KW	Guaranteed Efficiency:	85.5 %
RPM:	880	3/4 Load Efficiency:	87.9 %
Voltage:	460	KVA Code:	J
Hertz:	60	Max KVAR:	3.4
Amps - FL:	7.9	Power Factor:	68.5
Service Factor:	1.15	Bearing - DE:	6309ZC3
Alt Service Factor:	--	Bearing - ODE:	6309ZC3

Enclosure is Totally Enclosed Fan-Cooled

Stamped Nameplate Notes:

IEEE-STD-841-2009
 DE BRG 45BC03JP30 ODE BRG 45BC03JP30
 STAMP NP249A5564P051 AS BELOW:
 MODEL:5KS254XAA408D2 S/N: XXX
 CSA CERTIFIED CSA09.2216219 FOR EX NA IIC 200C GC
 CL 1 ZONE2 AEX NA IIC 200C;CL 1 DIV2 GRP ABCD 200C
 IN -25C <= AMB <= 40C, 1.0 SF ON SINE-WAVE PWR
 SURF TEMP 215C AT 1.15SF ON SINE-WAVE PWR
 OR 200 C VT OR 200 C CT OR 200 C CHP PWM CONTROL
 ALTERNATE RATING FOR PWM CONTROL 1.0SF 40C AMB
 VT 0-60 HZ, CT 3-60 HZ, CHP 60-90 HZ.



Additional Information:

8P - T EXTN
STANDARD FLOOR MOUNT
C/BOX 137 CU IN-1.25 NPT
F1 CONDUIT BOX MOUNTING
PAINTED FRAME ID & SHAFT,
FAN COVER INSIDE & ODE E/S OUTSIDE
ROUTINE AND 5 POINT VIBRATION TESTS INCL IN C/BOX
INPRO SEAL BOTH ENDS
GROUND SCREW ON FRAME
SHAFT RUNOUT LIMIT .001" TIR
COPPER WASHER UNDER HEADS OF BEARING CAP BOLTS
APPLY TITE-SEAL (A50CD427A) ON BEARING CAP SCREWS, RABBETS,
AND PLUG THREADS
OIL RESISTANT SLEEVING ON LEADS



Performance Characteristics

1st Winding 1st Connection

Design: 25BD4028A

Marks:

LOAD %	125.0	115.0	100.0	75.0	50.0	25.0	0.0
% EFF	86.6	87.12	87.89	87.94	86.56	79.93	0.00
% PF	73.32	71.72	68.55	60.57	47.91	29.3	5.25
AMPS	9.21	8.61	7.77	6.59	5.64	4.99	4.69

TORQ(FL)#FT	29.86	TORQ(LR)%FL	167.01	TORQ(BD)%FL	270.21
AMPS(LR)	40.56	PF AT START	0.36		

This motor is capable of two cold or one hot start with a maximum connected load inertia of 874 Lb-Ft Sq (36.8 Kg-meter Sq)at 100% voltage, where the load torque varies with the square of the speed. Acceleration time with maximum inertia and the above load type is 57 seconds. Safe stall time at 100% voltage is 127 seconds cold, 82 seconds hot. Rotor inertia is 1.57 Lb-Ft Sq (0.07 Kg-meter Sq).

Open Circuit A-C:	0.166	Short Circuit D-C:	0.01
Short Circuit A-C:	0.018	X/R Ratio:	3.9
Stator Slots:	54	Rotor Slots:	70

Speed Torque Current Curve (First Connection, First Speed)

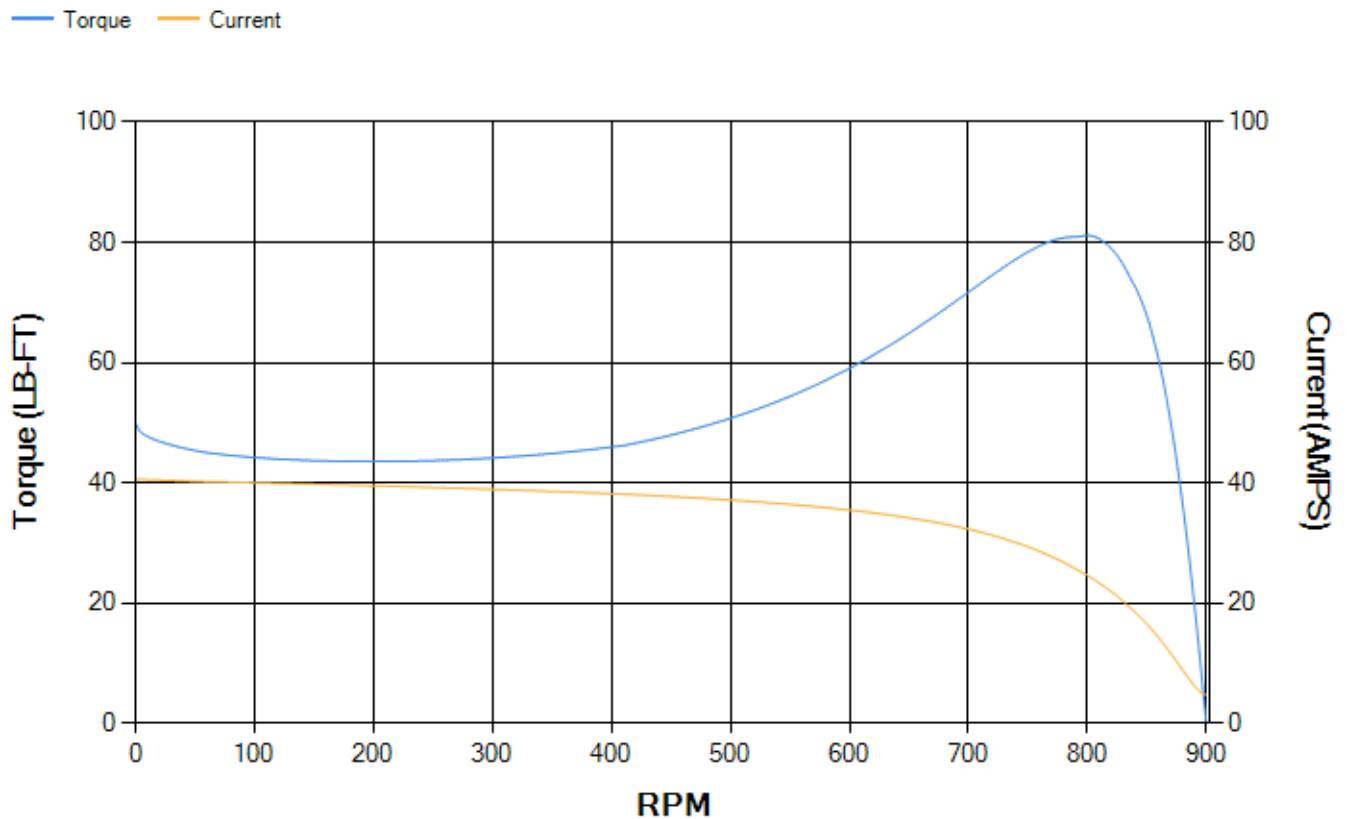

Marks:

NOTE 1: CONDUIT BOX MAY BE ASSEMBLED WITH ENTRANCE UP, DOWN OR TO EITHER SIDE.
 NOTE 2: F1 ASSEMBLY AS SHOWN. F2 ASSEMBLY CONDUIT BOX ON OPPOSITE SIDE FROM SHOWN LOCATION.
 NOTE 3: SHAFT RUNOUT WILL NOT EXCEED .001 T. I. R.

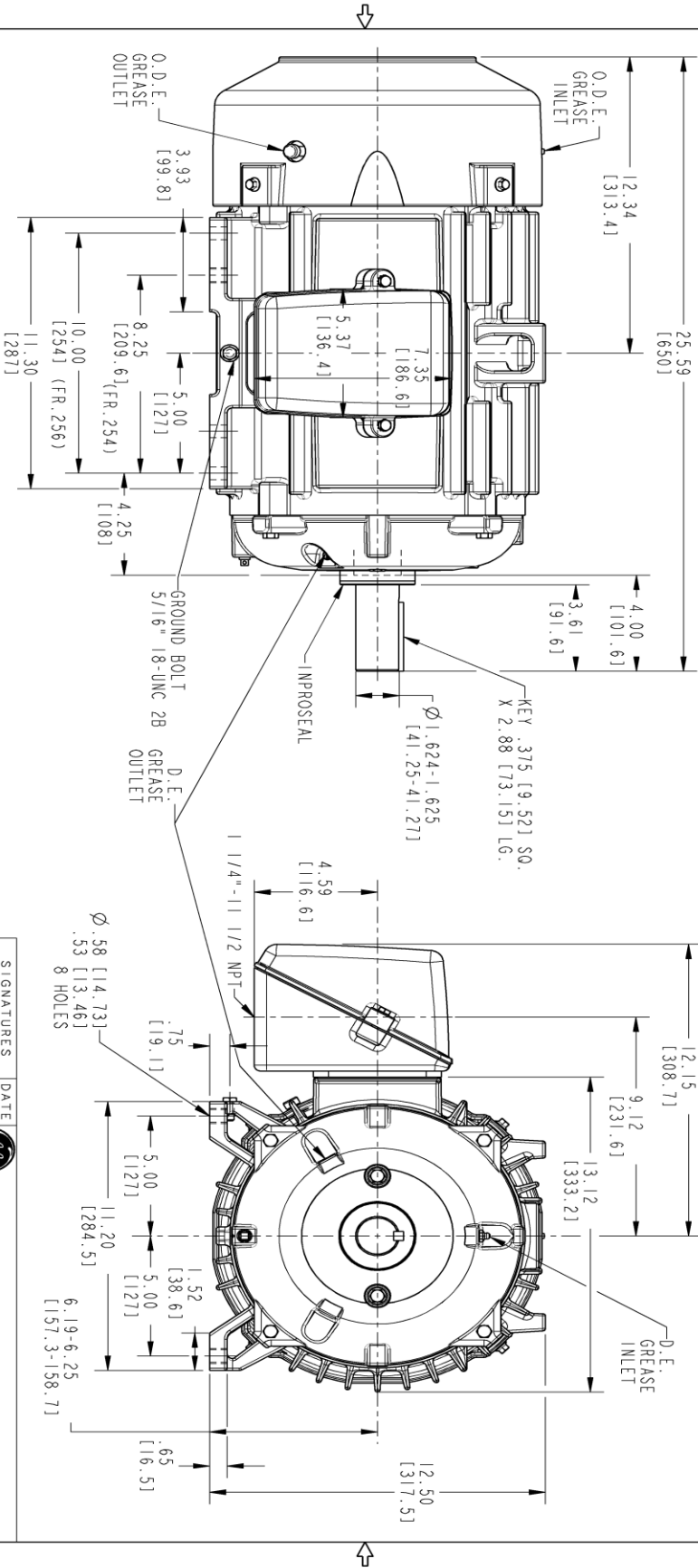

PROPRIETARY INFORMATION
 © COPYRIGHT 2018 Wolog Electric America LLC AND/OR ITS AFFILIATES.
 All rights reserved. This document and the information it contains is the property of Wolog Electric America LLC and/or its affiliates. It has been provided solely for transmission to the recipient for their use only. No other use, reproduction, or distribution is strictly prohibited except as expressly authorized in writing by Wolog Electric America LLC.

REV.	DESCRIPTION	DATE	APPROVED
1	ISAC# 18-0869	11/05/18	PRASHANTH

SIZE	DRAWING NO.	REV	SHEET
B	4002B5825PAP5311	001	1

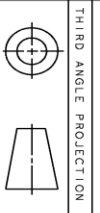

THIRD ANGLE PROJECTION

SIGNATURES	DATE	TITLE
TEJASNI	05/18/15	INDUCTION MOTOR OUTLINE
TEJASNI	05/18/15	STANDARD CONSTRUCTION FOR IEEE-941 SPEC.
KARTHIK	05/18/15	FMR FR250T TERC X8D ULTRA
SRIVANTHI	05/18/15	
TEJASNI	05/18/15	

GE INDUSTRIAL MOTORS
 a Wolog company

SCALE: 0.250 REF. No.: 4002B5825PAP301

4002B5825PAP5311

Marks:

Connection Diagram
GEM2034E-FIG7



End shield Assembly		
Part Description	DE Side Part#	ODE Side Part#
End Shield	4004D5283PB1	4004D5283SE1
Bearing	235A2507EB01	235A2507EB01
Slinger/Inproseal	4002B5914AF4	4002B5914AG4

Fan & Fan Cover Assembly	
Part Description	Part#
Fan	159C6800G01
Fan Cover	4003C5788PA1

Conduit & Accessories Box Assembly	
Part Description	Part#
Conduit Box	4002B5728PA-G04

Mechanical Accessories	
Part Description	Part#
Brake	
Tachometer	

