



GE INDUSTRIAL MOTORS
a **WOLONG** company

Product Technical Information

June 24, 2020

Data shown is for the current revision model #. Ensure your nameplate model # matches.

| | |
|----------------------------|-----------------------|
| Model Number: | 5KS256XAA408D2 |
| Catalog Number: | M9429 |
| Instruction Manual: | GEI-56128 |
| Connection Diagram: | GEM2034E-FIG7 |
| Outline Drawing: | 4002B5825PAP5311 |

Accessory Connection Diagrams

| | | | |
|------------------------------|------|------------------------------|------|
| Bearing Thermocouple: | None | Heater: | None |
| RTD: | None | Thermistor: | None |
| Thermostat: | None | Winding Thermocouple: | None |
| Bearing RTD: | None | | |

Table of Contents

| | |
|-----------------------------|----|
| Specification | 01 |
| Performance Characteristics | 02 |
| Outline Drawing | 03 |
| Connection Drawing(s) | 04 |
| Spare parts | 05 |

Marks:

| | | | |
|----------------------------|-----------------------|-------------------------------|---------|
| MODEL NUMBER: | 5KS256XAA408D2 | Estimated Weight: | 350 Lbs |
| Outline Drawing: | 4002B5825PAP5311 | Time Rating: | CONT |
| Connection Diagram: | GEM2034E-FIG7 | Enclosure: | TEFC |
| Instruction Book: | GEI-56128 | Encl Construction: | 841 |
| Design Code: | 25BD4020A | Ambient Max(°C): | 40 |
| Type: | KS | Alt Ambient Max(°C): | -- |
| Frame: | 256T | Insulation Class: | H |
| Phases: | 3 | NEMA Design: | B |
| Poles: | 8 | Nominal Efficiency: | 87.5 % |
| Output Power: | 7.5HP 5.6KW | Guaranteed Efficiency: | 86.5 % |
| RPM: | 875 | 3/4 Load Efficiency: | 89.2 % |
| Voltage: | 460 | KVA Code: | H |
| Hertz: | 60 | Max KVAR: | 4.3 |
| Amps - FL: | 11.1 | Power Factor: | 72.0 |
| Service Factor: | 1.15 | Bearing - DE: | 6309ZC3 |
| Alt Service Factor: | -- | Bearing - ODE: | 6309ZC3 |

Enclosure is Totally Enclosed Fan-Cooled

Stamped Nameplate Notes:

IEEE-STD-841-2009
 DE BRG 45BC03JP30 ODE BRG 45BC03JP30
 STAMP NP249A5564P051 AS BELOW:
 MODEL:5KS256XAA408D2 S/N: XXX
 CSA CERTIFIED CSA09.2216219 FOR EX NA IIC 200C GC
 CL 1 ZONE2 AEX NA IIC 200C;CL 1 DIV2 GRP ABCD 200C
 IN -25C <= AMB <= 40C, 1.0 SF ON SINE-WAVE PWR
 SURF TEMP 200C AT 1.15SF ON SINE-WAVE PWR
 OR 200 C VT OR 200 C CT OR 200 C CHP PWM CONTROL
 ALTERNATE RATING FOR PWM CONTROL 1.0SF 40C AMB
 VT 0-60 HZ, CT 3-60 HZ, CHP 60-90 HZ.



Additional Information:

8P - T EXTN
STANDARD FLOOR MOUNT
C/BOX 137 CU IN-1.25 NPT
F1 CONDUIT BOX MOUNTING
PAINTED FRAME ID & SHAFT,
FAN COVER INSIDE & ODE E/S OUTSIDE
ROUTINE AND 5 POINT VIBRATION TESTS INCL IN C/BOX
INPRO SEAL BOTH ENDS
GROUND SCREW ON FRAME
SHAFT RUNOUT LIMIT .001" TIR
COPPER WASHER UNDER HEADS OF BEARING CAP BOLTS
APPLY TITE-SEAL (A50CD427A) ON BEARING CAP SCREWS, RABBETS,
AND PLUG THREADS
OIL RESISTANT SLEEVING ON LEADS



Performance Characteristics

1st Winding 1st Connection

Design: 25BD4020A

Marks:

| LOAD % | 125.0 | 115.0 | 100.0 | 75.0 | 50.0 | 25.0 | 0.0 |
|--------|-------|-------|-------|-------|-------|-------|------|
| % EFF | 86.83 | 87.55 | 88.63 | 89.25 | 88.7 | 83.83 | 0.00 |
| % PF | 75.45 | 74.32 | 71.83 | 64.85 | 52.55 | 32.51 | 4.62 |
| AMPS | 13.39 | 12.41 | 11.03 | 9.1 | 7.53 | 6.44 | 5.93 |

| | | | | | |
|--------------------|-------|--------------------|-------|--------------------|--------|
| TORQ(FL)#FT | 44.98 | TORQ(LR)%FL | 154.6 | TORQ(BD)%FL | 242.96 |
| AMPS(LR) | 54.41 | PF AT START | 0.34 | | |

This motor is capable of two cold or one hot start with a maximum connected load inertia of 1233 Lb-Ft Sq (51.91 Kg-meter Sq) at 100% voltage, where the load torque varies with the square of the speed. Acceleration time with maximum inertia and the above load type is 59 seconds. Safe stall time at 100% voltage is 142 seconds cold, 86 seconds hot. Rotor inertia is 2.09 Lb-Ft Sq (0.09 Kg-meter Sq).

| | | | |
|---------------------------|-------|---------------------------|-------|
| Open Circuit A-C: | 0.166 | Short Circuit D-C: | 0.012 |
| Short Circuit A-C: | 0.017 | X/R Ratio: | 4.461 |
| Stator Slots: | 54 | Rotor Slots: | 70 |

Speed Torque Current Curve (First Connection, First Speed)

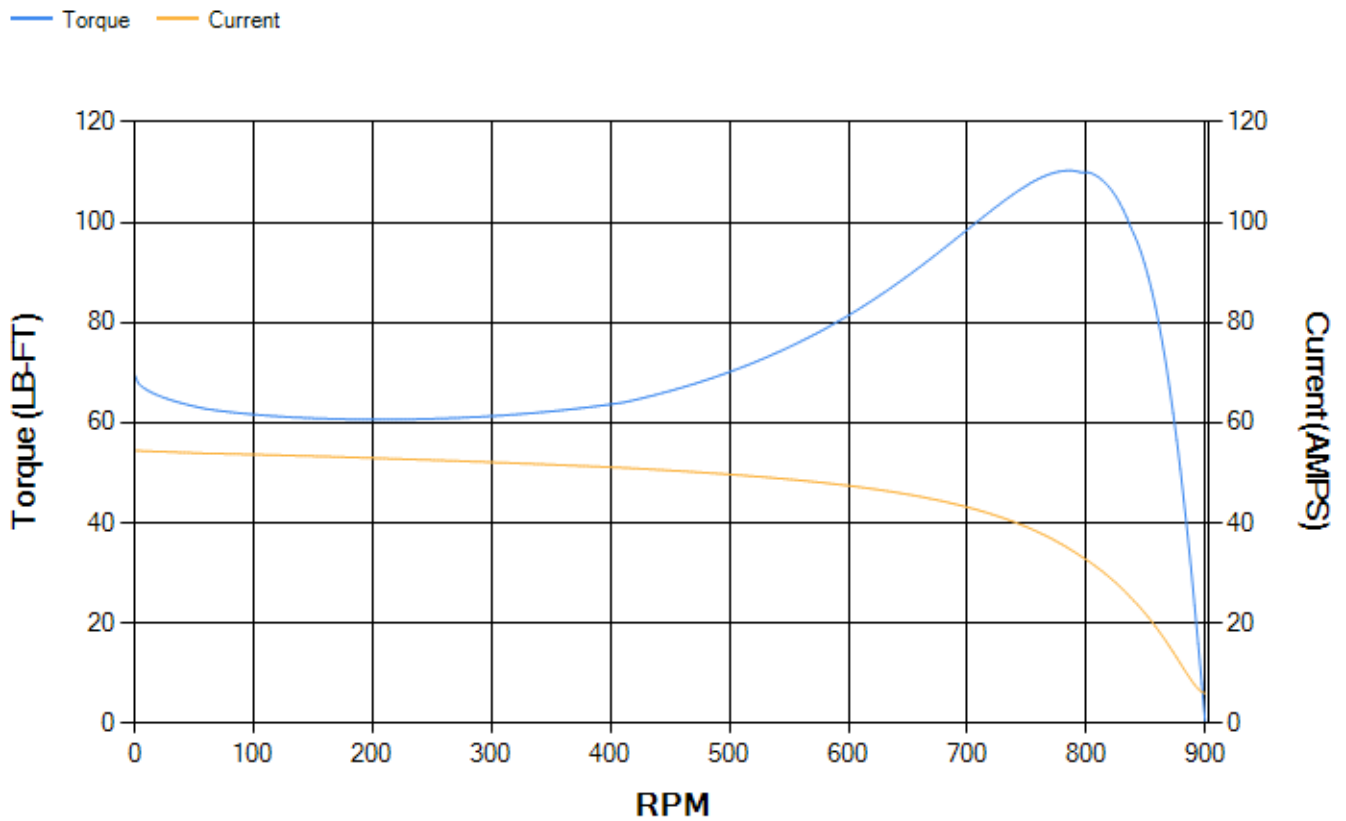

Marks:

NOTE 1: CONDUIT BOX MAY BE ASSEMBLED WITH ENTRANCE UP, DOWN OR TO EITHER SIDE.
 NOTE 2: F1 ASSEMBLY AS SHOWN. F2 ASSEMBLY CONDUIT BOX ON OPPOSITE SIDE FROM SHOWN LOCATION.
 NOTE 3: SHAFT RUNOUT WILL NOT EXCEED .001 T. I. R.

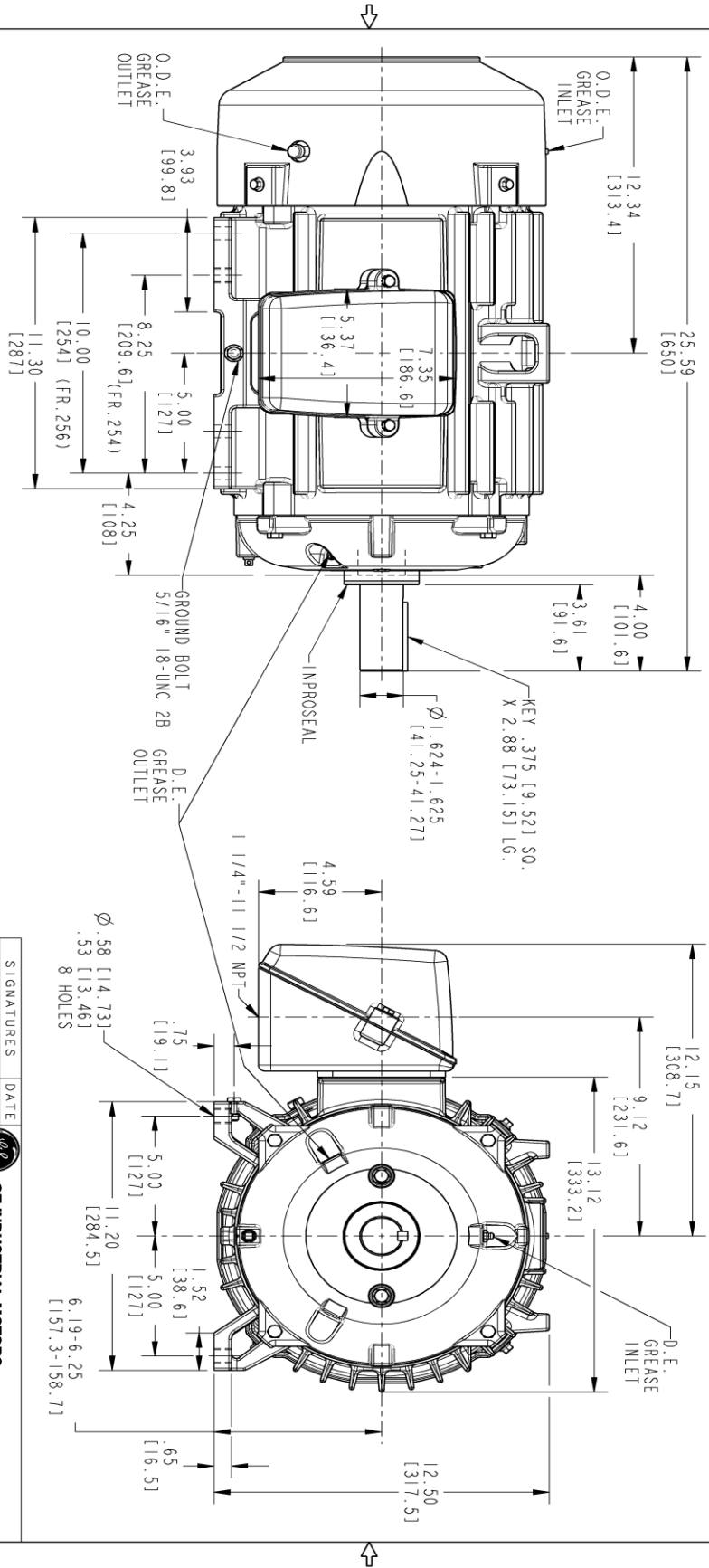

PROPRIETARY INFORMATION
 © COPYRIGHT 2018 Wolog Electric America LLC AND/OR ITS AFFILIATES.
 All rights reserved. This document and the information it contains is the property of the Wolog Electric America LLC and/or its affiliates. It has been provided solely for transmission to the applicable recipient for the sole and exclusive use of the recipient. It is strictly prohibited to copy, reproduce, or disseminate this information in any form or by any means without the express written authorization of the Wolog Electric America LLC.

| REV. | DESCRIPTION | DATE | APPROVED |
|------|---------------|----------|-----------|
| 1 | ISAC# 18-0869 | 11/05/18 | PRASHANTH |

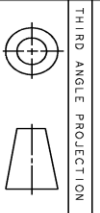

THIRD ANGLE PROJECTION

| SIGNATURES | DATE |
|------------|----------|
| TEJASNI | 05/18/15 |
| TEJASNI | 05/18/15 |
| KARTHIK | 05/18/15 |
| SRIVANTHI | 05/18/15 |

GE INDUSTRIAL MOTORS
 a Wolog company

TITLE
INDUCTION MOTOR OUTLINE
 STANDARD CONSTRUCTION FOR IEEE-941 SPEC.
 FMR FR250T TERC X8D ULTRA

SCALE: 0.250 REF. No.: 4002B5825PAP5311

4002B5825PAP5311

Marks:

Connection Diagram
GEM2034E-FIG7



| End shield Assembly | | |
|---------------------|---------------|----------------|
| Part Description | DE Side Part# | ODE Side Part# |
| End Shield | 4004D5283PB1 | 4004D5283SE1 |
| Bearing | 235A2507EB01 | 235A2507EB01 |
| Slinger/Inproseal | 4002B5914AF4 | 4002B5914AG4 |

| Fan & Fan Cover Assembly | |
|--------------------------|--------------|
| Part Description | Part# |
| Fan | 159C6800G01 |
| Fan Cover | 4003C5788PA1 |

| Conduit & Accessories Box Assembly | |
|------------------------------------|-----------------|
| Part Description | Part# |
| Conduit Box | 4002B5728PA-G04 |

| Mechanical Accessories | |
|------------------------|-------|
| Part Description | Part# |
| Brake | |
| Tachometer | |

