



GE INDUSTRIAL MOTORS
a **WOLONG** company

Product Technical Information

June 24, 2020

Data shown is for the current revision model #. Ensure your nameplate model # matches.

Model Number:	5KS286XAA208D2
Catalog Number:	M9447
Instruction Manual:	GEI-56128
Connection Diagram:	GEM2034E-FIG7
Outline Drawing:	4002B5828PAP5311

Accessory Connection Diagrams

Bearing Thermocouple:	None	Heater:	None
RTD:	None	Thermistor:	None
Thermostat:	None	Winding Thermocouple:	None
Bearing RTD:	None		

Table of Contents

Specification	01
Performance Characteristics	02
Outline Drawing	03
Connection Drawing(s)	04
Spare parts	05

Marks:

MODEL NUMBER:	5KS286XAA208D2	Estimated Weight:	510 Lbs
Outline Drawing:	4002B5828PAP5311	Time Rating:	CONT
Connection Diagram:	GEM2034E-FIG7	Enclosure:	TEFC
Instruction Book:	GEI-56128	Encl Construction:	841
Design Code:	28BD1157A	Ambient Max(°C):	40
Type:	KS	Alt Ambient Max(°C):	--
Frame:	286T	Insulation Class:	H
Phases:	3	NEMA Design:	B
Poles:	4	Nominal Efficiency:	93.6 %
Output Power:	30HP 22.2KW	Guaranteed Efficiency:	93.0 %
RPM:	1775	3/4 Load Efficiency:	94.1 %
Voltage:	460	KVA Code:	G
Hertz:	60	Max KVAR:	8.2
Amps - FL:	34.9	Power Factor:	86.0
Service Factor:	1.15	Bearing - DE:	6310ZC3
Alt Service Factor:	--	Bearing - ODE:	6310ZC3

Enclosure is Totally Enclosed Fan-Cooled

Stamped Nameplate Notes:

IEEE-STD-841-2009
 DE BRG 50BC03JP30 ODE BRG 50BC03JP30
 STAMP NP249A5564P051 AS BELOW:
 MODEL:5KS286XAA208D2 S/N: XXX
 CSA CERTIFIED CSA09.2216219 FOR EX NA IIC 200 C GC
 CL1ZONE2 AEXNAIIC 200 C; CL1DIV2 GRP ABCD 200 C
 IN -25C <= AMB <= 40C, 1.0 SF ON SINE-WAVE PWR
 SURF TEMP 200 C AT 1.15 SF ON SINE-WAVE PWR
 OR 200 C VT OR 200 C CT OR 200 C CHP PWM CONTROL
 ALTERNATE RATING FOR PWM CONTROL 1.0 SF 40 C AMB
 VT 0-60 HZ, CT 6-60 HZ, CHP 60-90 HZ.



Additional Information:

4P - T EXTN
STANDARD FLOOR MOUNT
C/BOX 137 CU IN-1.50 NPT
F1 CONDUIT BOX MOUNTING
PAINTED FRAME ID & SHAFT,
FAN COVER INSIDE & ODE E/S OUTSIDE
ROUTINE AND 5 POINT VIBRATION TESTS INCL IN C/BOX
INPRO SEAL BOTH ENDS
GROUND SCREW ON FRAME
SHAFT RUNOUT LIMIT .0015" TIR
COPPER WASHER UNDER HEADS OF BEARING CAP BOLTS
APPLY TITE-SEAL (A50CD427A) ON BEARING CAP SCREWS, RABBETS,
AND PLUG THREADS
OIL RESISTANT SLEEVING ON LEADS



Performance Characteristics

1st Winding 1st Connection

Design: 28BD1157A

Marks:

LOAD %	125.0	115.0	100.0	75.0	50.0	25.0	0.0
% EFF	92.5	92.93	93.68	94.1	94.05	91.74	0.00
% PF	86.91	86.73	86.02	82.95	74.96	53.68	4.49
AMPS	43.66	40.06	34.83	26.98	19.91	14.25	11.5

TORQ(FL)#FT	88.62	TORQ(LR)%FL	184.77	TORQ(BD)%FL	281.74
AMPS(LR)	216.09	PF AT START	0.38		

This motor is capable of two cold or one hot start with a maximum connected load inertia of 969 Lb-Ft Sq (40.79 Kg-meter Sq)at 100% voltage, where the load torque varies with the square of the speed. Acceleration time with maximum inertia and the above load type is 51 seconds. Safe stall time at 100% voltage is 90 seconds cold, 61 seconds hot. Rotor inertia is 5.39 Lb-Ft Sq (0.23 Kg-meter Sq).

Open Circuit A-C:	0.634	Short Circuit D-C:	0.016
Short Circuit A-C:	0.027	X/R Ratio:	5.921
Stator Slots:	48	Rotor Slots:	40

Speed Torque Current Curve (First Connection, First Speed)

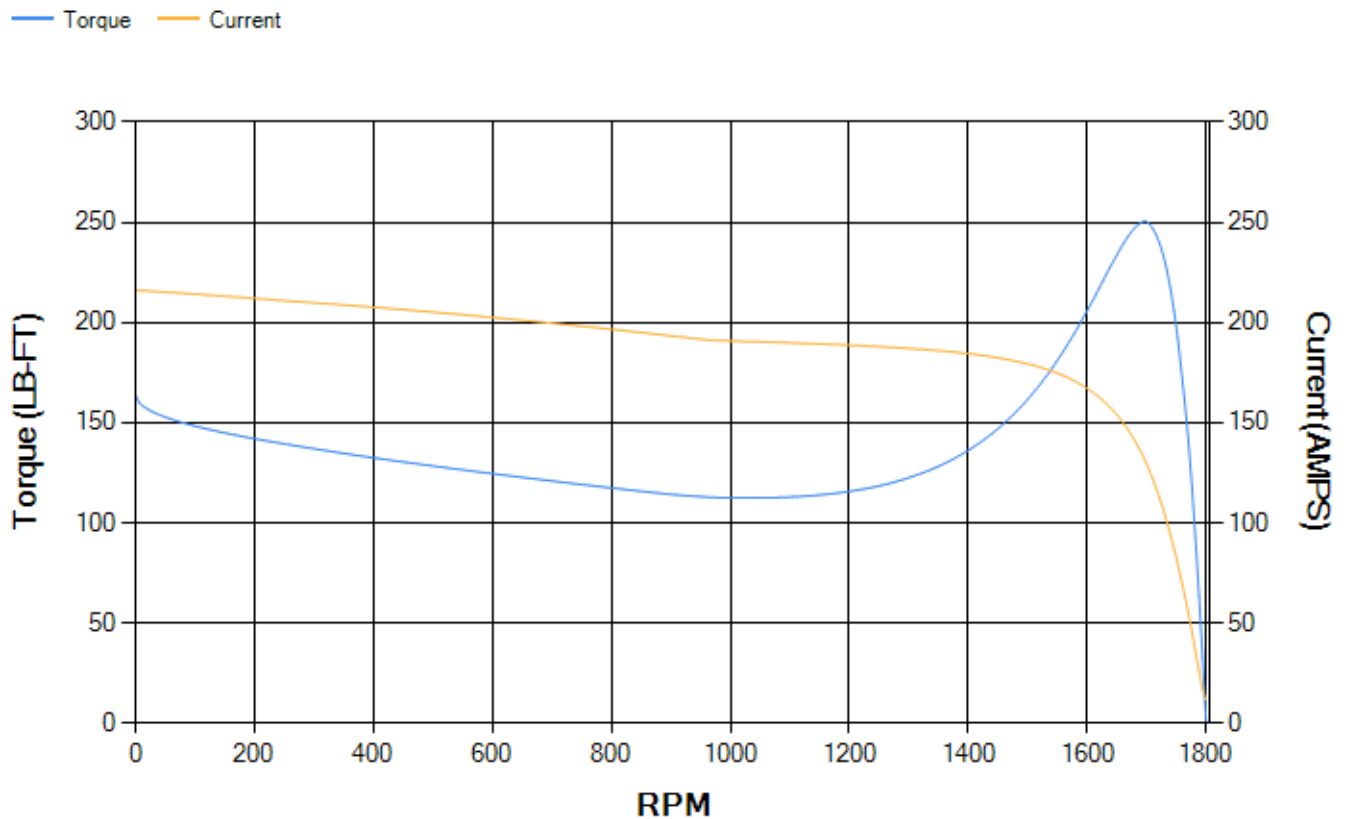

Marks:

NOTE 1: CONDUIT BOX MAY BE ASSEMBLED WITH ENTRANCE UP, DOWN OR TO EITHER SIDE.
 NOTE 2: F1 ASSEMBLY AS SHOWN. F2 ASSEMBLY CONDUIT BOX ON OPPOSITE SIDE FROM SHOWN LOCATION.
 NOTE 3: SHAFT RUNOUT WILL NOT EXCEED .0015 T.I.R.
 NOTE 4: ALL DIMENSIONS ARE IN INCHES. BRACKETED DIMENSIONS ARE IN METRIC (MILLIMETERS).

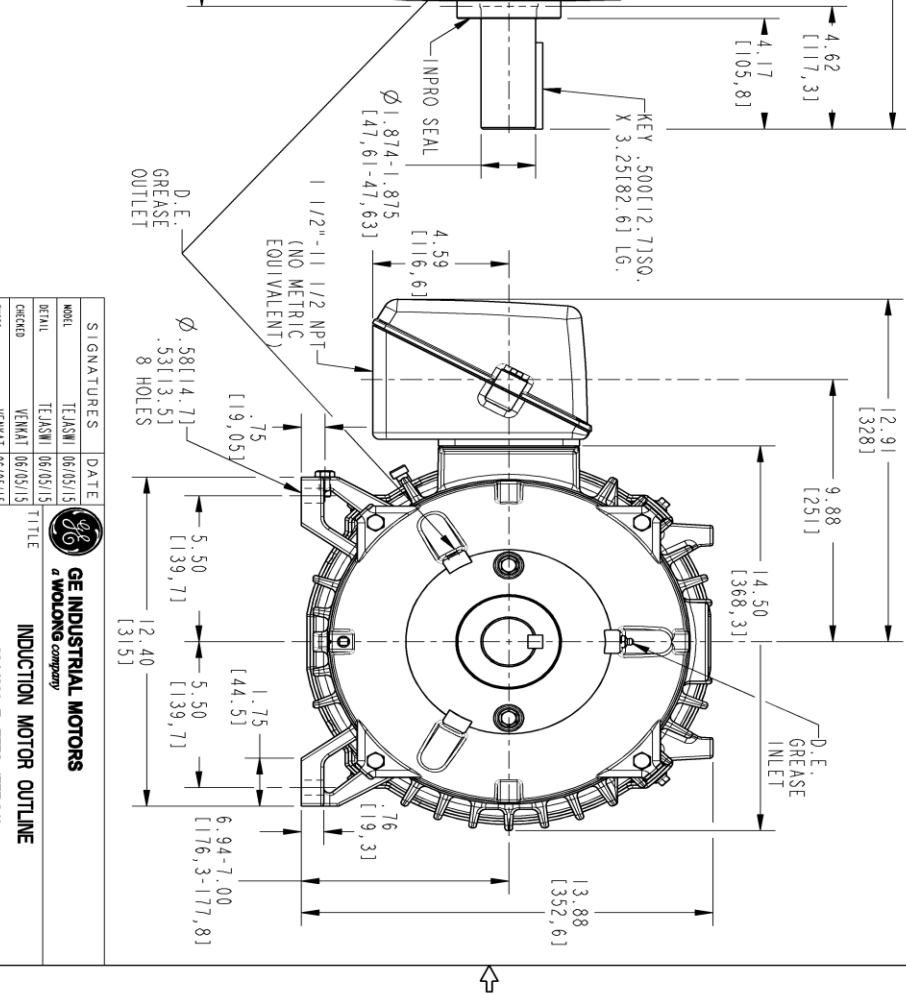
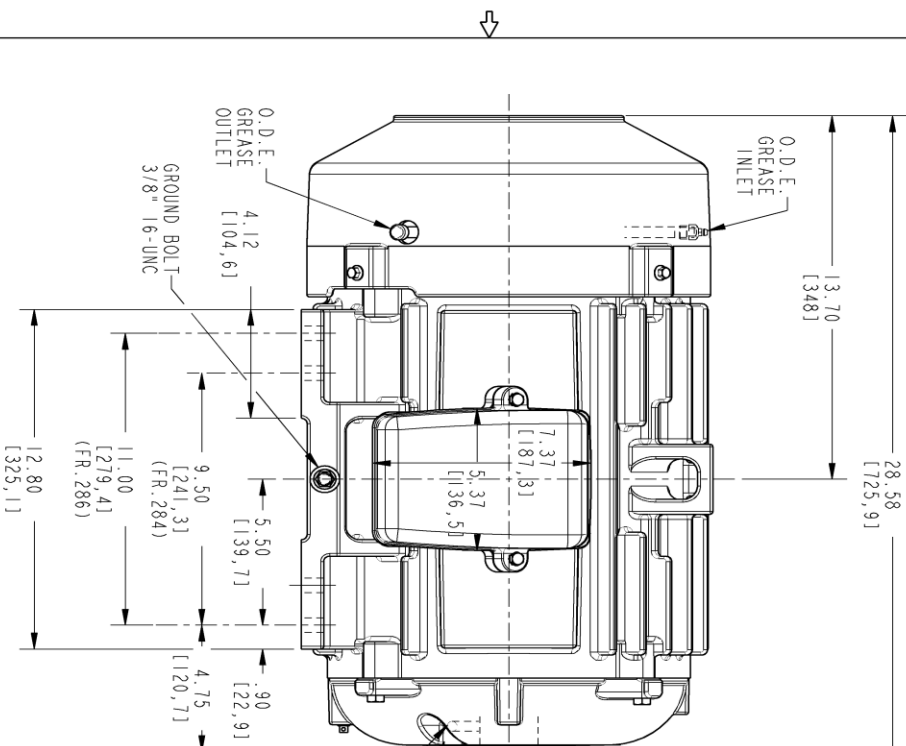

PROPRIETARY INFORMATION
 © COPYRIGHT 2018 Wolog Electric America LLC AND/OR ITS AFFILIATES
 All rights reserved. This document and the information it contains is the property of Wolog Electric America LLC and/or its affiliates. It has been provided solely for transmission to the recipient for their use only. No part of this document or information is to be reproduced, stored in a retrieval system, or transmitted in any form or by any means, electronic, mechanical, photocopying, recording, or by any information storage and retrieval system, without the prior written permission of Wolog Electric America LLC. This document is strictly prohibited from being used for any other purpose without the prior written permission of Wolog Electric America LLC.

REV.	DESCRIPTION	DATE	APPROVED
1	ISAC# 18-0869	11/08/18	PRASHANTH

REV	SHEET	REV	SHEET
B	1	001	1

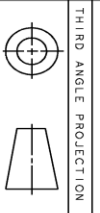

SIGNATURES	DATE
MODEL: TEJASNI	06/05/19
DETAIL: TEJASNI	06/05/19
CHECKED: VENKAT	06/05/19
ENG: VENKAT	06/05/19
QC: VENKAT	06/05/19
ISSUED: TEJASNI	06/05/19



TITLE
INDUCTION MOTOR OUTLINE
 284/286 T, TFC, IEE-94I
 CBOX 137 CUL - 150 NPT, IMPRO SEAL, GROUND PAD
4002B5828PAP5311

SCALE: 0.250 REF. No.: 4002B5828PAP5301

SHEET 1 OF 1

Marks:

Connection Diagram
GEM2034E-FIG7



End shield Assembly		
Part Description	DE Side Part#	ODE Side Part#
End Shield	4004D5284PB1	4004D5284SE1
Bearing	235A2508EC01	235A2508EC01
Slinger/Inproseal	4002B5914AF5	4002B5914AG5

Fan & Fan Cover Assembly	
Part Description	Part#
Fan	159C6900G01
Fan Cover	4003C5789PA1

Conduit & Accessories Box Assembly	
Part Description	Part#
Conduit Box	4002B5728PA-G01

Mechanical Accessories	
Part Description	Part#
Brake	
Tachometer	

