



**GE INDUSTRIAL MOTORS**  
a **WOLONG** company

# Product Technical Information

June 24, 2020

Data shown is for the current revision model #. Ensure your nameplate model # matches.

<b>Model Number:</b>	<b>5KS184XAA104D4</b>
<b>Catalog Number:</b>	<b>M9492</b>
<b>Instruction Manual:</b>	GEI-56128
<b>Connection Diagram:</b>	GEM2034E-FIG1
<b>Outline Drawing:</b>	4002B5818PAP5311

## Accessory Connection Diagrams

<b>Bearing Thermocouple:</b>	None	<b>Heater:</b>	None
<b>RTD:</b>	None	<b>Thermistor:</b>	None
<b>Thermostat:</b>	None	<b>Winding Thermocouple:</b>	None
<b>Bearing RTD:</b>	None		

## Table of Contents

Specification	01
Performance Characteristics	02
Outline Drawing	03
Connection Drawing(s)	04
Spare parts	05

Marks:

<b>MODEL NUMBER:</b>	<b>5KS184XAA104D4</b>	<b>Estimated Weight:</b>	101 Lbs
<b>Outline Drawing:</b>	4002B5818PAP5311	<b>Time Rating:</b>	CONT
<b>Connection Diagram:</b>	GEM2034E-FIG1	<b>Enclosure:</b>	TEFC
<b>Instruction Book:</b>	GEI-56128	<b>Encl Construction:</b>	841
<b>Design Code:</b>	18BD0103B	<b>Ambient Max(°C):</b>	40
<b>Type:</b>	KS	<b>Alt Ambient Max(°C):</b>	--
<b>Frame:</b>	184T	<b>Insulation Class:</b>	H
<b>Phases:</b>	3	<b>NEMA Design:</b>	B
<b>Poles:</b>	2	<b>Nominal Efficiency:</b>	88.5 %
<b>Output Power:</b>	5HP 3.7KW	<b>Guaranteed Efficiency:</b>	87.5 %
<b>RPM:</b>	3530	<b>3/4 Load Efficiency:</b>	89.2 %
<b>Voltage:</b>	575	<b>KVA Code:</b>	J
<b>Hertz:</b>	60	<b>Max KVAR:</b>	1.9
<b>Amps - FL:</b>	5.3	<b>Power Factor:</b>	80.5
<b>Service Factor:</b>	1.15	<b>Bearing - DE:</b>	6206ZC3
<b>Alt Service Factor:</b>	--	<b>Bearing - ODE:</b>	6206ZC3

Enclosure is Totally Enclosed Fan-Cooled

---

Stamped Nameplate Notes:

IEEE-STD-841-2009  
 DE BRG 30BC02JP30 ODE BRG 30BC02JP30  
 STAMP NP249A5564P051 AS BELOW:  
 MODEL:5KS184XAA104D4 S/N: XXX  
 CSA CERTIFIED CSA09.2216219 FOR EX NA IIC 200 C GC  
 CL1 ZONE2 AEXNAIIC 200C FOR CL1DIV2 GRP ABCD 200C  
 IN -25C <= AMB <= 40C, 1.0 SF ON SINE-WAVE PWR  
 SURF TEMP 200 C AT 1.15 SF ON SINE-WAVE PWR  
 OR 200 C VT OR 215 C CT OR 200 C CHP PWM CONTROL  
 ALTERNATE RATING FOR PWM CONTROL 1.0 SF 40 C AMB  
 VT 0-60 HZ, CT 3-60 HZ, CHP 60-90 HZ.



**Additional Information:**

2P - T EXTN  
STANDARD FLOOR MOUNT  
C/BOX 55 CU IN-1.00 NPT  
F1 CONDUIT BOX MOUNTING  
PAINTED FRAME ID & SHAFT,  
FAN COVER INSIDE & ODE E/S OUTSIDE  
ROUTINE AND 5 POINT VIBRATION TESTS INCL IN C/BOX  
INPRO SEAL BOTH ENDS  
GROUND SCREW ON FRAME  
SHAFT RUNOUT LIMIT .001" TIR  
COPPER WASHER UNDER HEADS OF BEARING CAP BOLTS  
APPLY TITE-SEAL (A50CD427A) ON BEARING CAP SCREWS, RABBETS,  
AND PLUG THREADS  
OIL RESISTANT SLEEVING ON LEADS



**Performance Characteristics**

1st Winding 1st Connection

**Design: 18BD0103B**

**Marks:**

LOAD %	125.0	115.0	100.0	75.0	50.0	25.0	0.0
% EFF	88.48	88.83	89.39	89.19	87.72	81.32	0.00
% PF	82.98	82.02	83.74	74.07	62.7	41.42	8.87
AMPS	6.37	5.91	5	4.25	3.4	2.78	2.15

<b>TORQ(FL)#FT</b>	7.44	<b>TORQ(LR)%FL</b>	213.64	<b>TORQ(BD)%FL</b>	337.23
<b>AMPS(LR)</b>	34.69	<b>PF AT START</b>	0.41		

This motor is capable of two cold or one hot start with a maximum connected load inertia of 44 Lb-Ft Sq (1.85 Kg-meter Sq)at 100% voltage, where the load torque varies with the square of the speed. Acceleration time with maximum inertia and the above load type is 37 seconds. Safe stall time at 100% voltage is 78 seconds cold, 55 seconds hot. Rotor inertia is 0.15 Lb-Ft Sq (0.01 Kg-meter Sq).

<b>Open Circuit A-C:</b>	0.297	<b>Short Circuit D-C:</b>	0.01
<b>Short Circuit A-C:</b>	0.017	<b>X/R Ratio:</b>	3.892
<b>Stator Slots:</b>	36	<b>Rotor Slots:</b>	28

**Speed Torque Current Curve (First Connection, First Speed)**

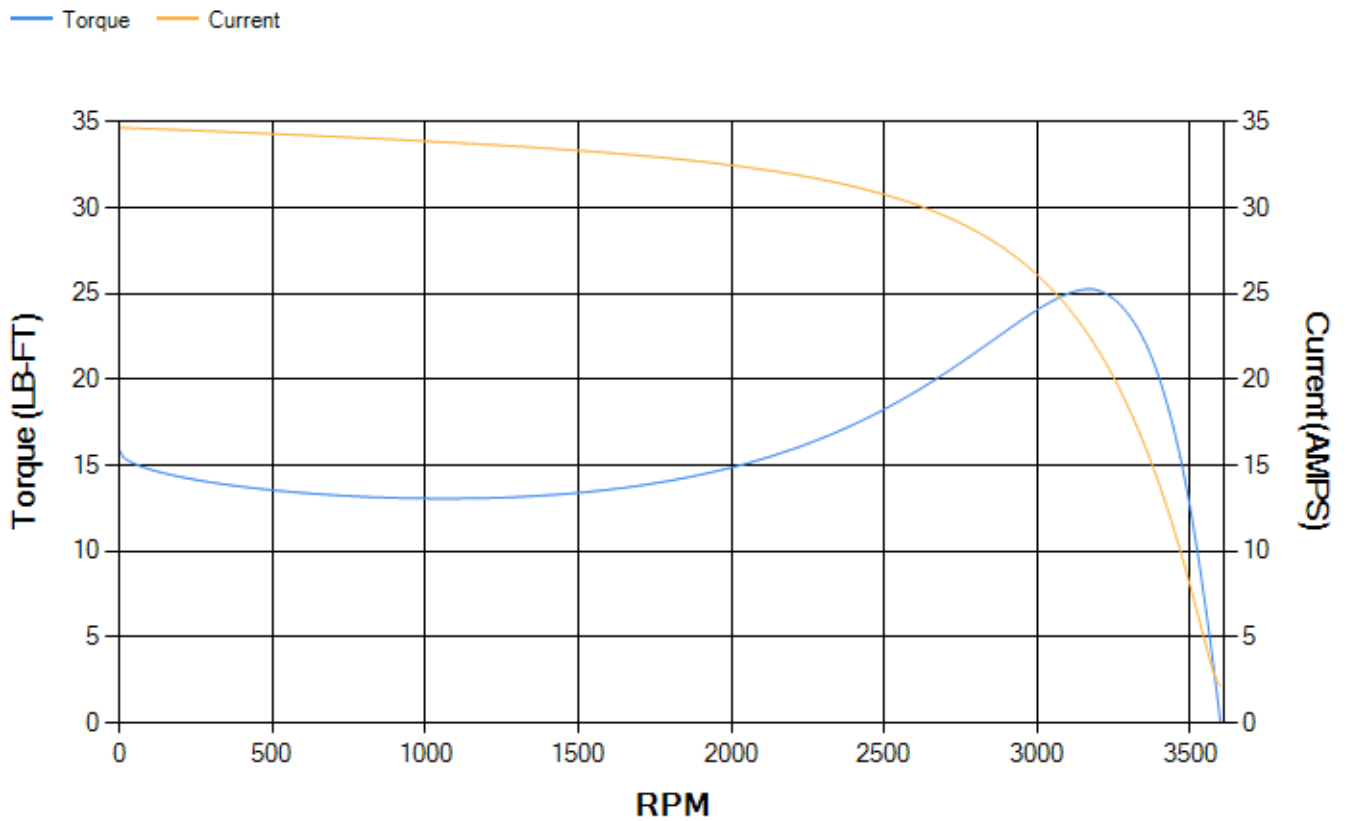

Marks:

NOTE 1: CONDUIT BOX MAY BE ASSEMBLED WITH ENTRANCE UP, DOWN OR TO EITHER SIDE.  
 NOTE 2: F1 ASSEMBLY AS SHOWN. F2 ASSEMBLY CONDUIT BOX ON OPPOSITE SIDE FROM SHOWN LOCATION.  
 NOTE 3: SHAFT RUNOUT WILL NOT EXCEED .001 T.I.R.  
 NOTE 4: ALL DIMENSIONS ARE IN INCHES, BRACKETED DIMENSIONS ARE IN METRIC (MILLIMETERS).

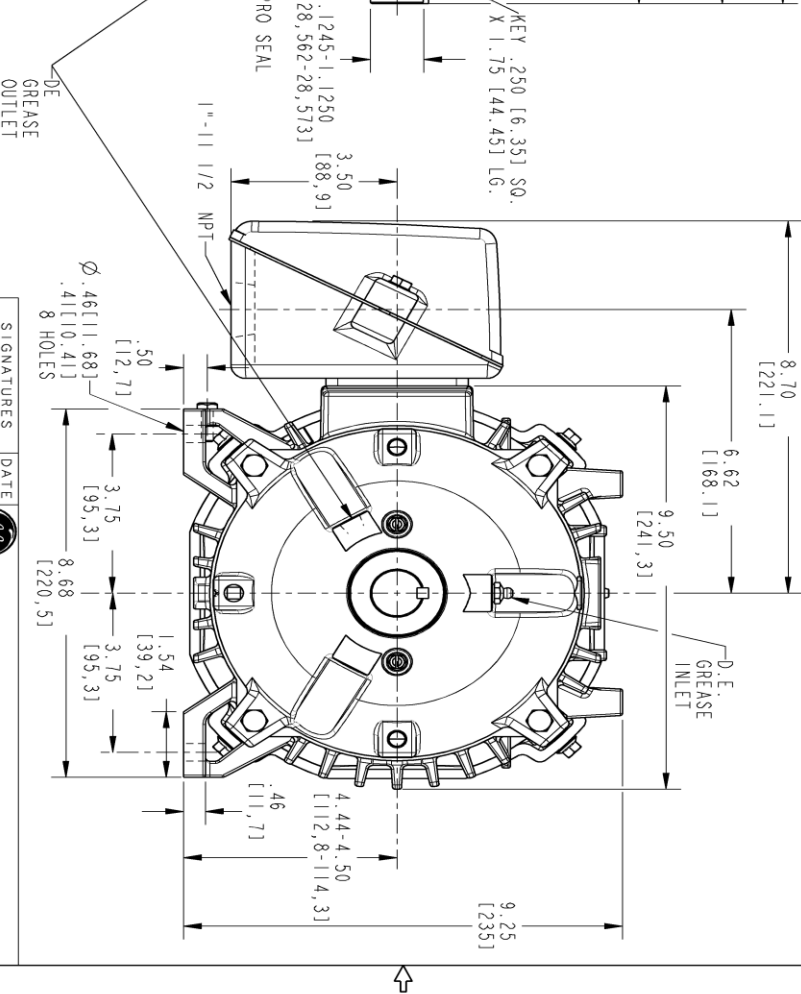
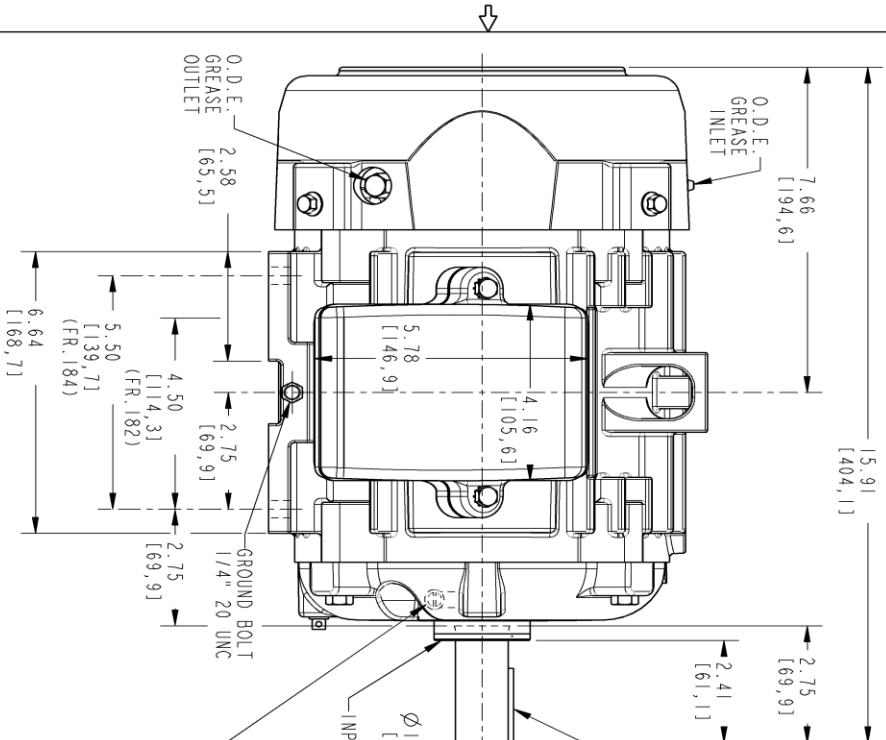

**PROPRIETARY INFORMATION**  
 © COPYRIGHT 2018 Wolog Electric America LLC AND/OR ITS AFFILIATES. All rights reserved. This document and the information it contains is the property of the Wolog Electric America LLC and/or its affiliates. It has been provided solely for transmission for design and manufacturing purposes and is not to be distributed, copied, or used in any other way without the express written consent of Wolog Electric America LLC.

REVISIONS			
REV.	DESCRIPTION	DATE	APPROVED
1	ISAC #15-0731	07/17/15	KARTHIK
2	ISAC #16-0079	01/28/16	SRAVANTHI D
3	ISAC# 18-0869	10/28/18	PRAASHANTH

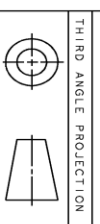

MODEL	TEJASNI	06/04/15
DETAIL	TEJASNI	06/04/15
CREATED	VENKAT	06/04/15
CHKD	VENKAT	06/04/15
QUALITY	TEJASNI	06/04/15
ISSUED	B	
SOLID MODEL:	4002B5818PAP5311	
SCALE:	0.400 [REF. No.: 4002B5818PAP5301]	
TITLE	INDUCTION MOTOR OUTLINE	
STANDARD CONSTRUCTION FOR IEEE-941 SPEC		
FR18Z/94 T TERC		
REV	4002B5818PAP5311	
SHEET	1 OF 1	

SIZE DRAWING NO. **4002B5818PAP5311 003**

**Marks:**

**Connection Diagram**  
**GEM2034E-FIG1**

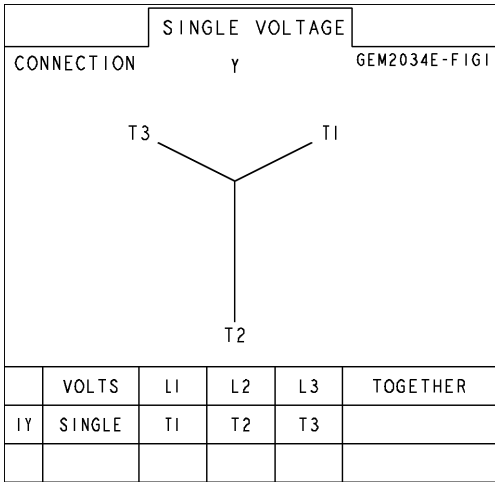

End shield Assembly		
Part Description	DE Side Part#	ODE Side Part#
End Shield	4004D5281PB1	4004D5281SG1
Bearing	235A2502AM01	235A2502AM01
Slinger/Inproseal	4002B5914AF2	4002B5914AG2

Fan & Fan Cover Assembly	
Part Description	Part#
Fan	4001A5914AM-G01
Fan Cover	4003C5786PA1

Conduit & Accessories Box Assembly	
Part Description	Part#
Conduit Box	4002B5721PA-G01

Mechanical Accessories	
Part Description	Part#
Brake	
Tachometer	

