



GE INDUSTRIAL MOTORS
a **WOLONG** company

Product Technical Information

June 24, 2020

Data shown is for the current revision model #. Ensure your nameplate model # matches.

Model Number:	5KS215XAA304D2
Catalog Number:	M9494
Instruction Manual:	GEI-56128
Connection Diagram:	GEM2034E-FIG1
Outline Drawing:	4002B5821PAP5311

Accessory Connection Diagrams

Bearing Thermocouple:	None	Heater:	None
RTD:	None	Thermistor:	None
Thermostat:	None	Winding Thermocouple:	None
Bearing RTD:	None		

Table of Contents

Specification	01
Performance Characteristics	02
Outline Drawing	03
Connection Drawing(s)	04
Spare parts	05

Marks:

MODEL NUMBER:	5KS215XAA304D2	Estimated Weight:	220 Lbs
Outline Drawing:	4002B5821PAP5311	Time Rating:	CONT
Connection Diagram:	GEM2034E-FIG1	Enclosure:	TEFC
Instruction Book:	GEI-56128	Encl Construction:	841
Design Code:	21BD3000B	Ambient Max(°C):	40
Type:	KS	Alt Ambient Max(°C):	--
Frame:	215T	Insulation Class:	H
Phases:	3	NEMA Design:	B
Poles:	6	Nominal Efficiency:	89.5 %
Output Power:	5HP 3.7KW	Guaranteed Efficiency:	88.5 %
RPM:	1170	3/4 Load Efficiency:	90.5 %
Voltage:	575	KVA Code:	J
Hertz:	60	Max KVAR:	2.2
Amps - FL:	5.5	Power Factor:	76.5
Service Factor:	1.15	Bearing - DE:	6208ZC3
Alt Service Factor:	--	Bearing - ODE:	6208ZC3

Enclosure is Totally Enclosed Fan-Cooled

Stamped Nameplate Notes:

IEEE-STD-841-2009
 DE BRG 40BC02JP30 ODE BRG 40BC02JP30
 STAMP NP249A5564P051 AS BELOW:
 MODEL:5KS215XAA304D2 S/N: XXX
 CSA CERTIFIED CSA09.2216219 FOR EX NA IIC 200C GC
 CL 1 ZONE2 AEX NA IIC 200C;CL 1 DIV2 GRP ABCD 200C
 IN -25C <= AMB <= 40C, 1.0 SF ON SINE-WAVE PWR
 SURF TEMP 200C AT 1.15SF ON SINE-WAVE PWR
 OR 200 C VT OR 200 C CT OR 200 C CHP PWM CONTROL
 ALTERNATE RATING FOR PWM CONTROL 1.0SF 40C AMB
 VT 0-60 HZ, CT 3-60 HZ, CHP 60-90 HZ.



Additional Information:

6P - T EXTN
STANDARD FLOOR MOUNT
C/BOX 55 CU IN-1.00 NPT
F1 CONDUIT BOX MOUNTING
PAINTED FRAME ID & SHAFT,
FAN COVER INSIDE & ODE E/S OUTSIDE
ROUTINE AND 5 POINT VIBRATION TESTS INCL IN C/BOX
INPRO SEAL BOTH ENDS
GROUND SCREW ON FRAME
SHAFT RUNOUT LIMIT .001" TIR
COPPER WASHER UNDER HEADS OF BEARING CAP BOLTS
APPLY TITE-SEAL (A50CD427A) ON BEARING CAP SCREWS, RABBETS,
AND PLUG THREADS
OIL RESISTANT SLEEVING ON LEADS



Performance Characteristics

1st Winding 1st Connection

Design: 21BD300B

Marks:

LOAD %	125.0	115.0	100.0	75.0	50.0	25.0	0.0
% EFF	88.1	88.79	89.84	90.48	90.15	86.04	0.00
% PF	79.05	78.36	76.62	71.06	59.88	38.7	5.07
AMPS	6.72	6.19	5.44	4.37	3.47	2.81	2.5

TORQ(FL)#FT	22.4	TORQ(LR)%FL	191.85	TORQ(BD)%FL	289.97
AMPS(LR)	35.04	PF AT START	0.46		

This motor is capable of two cold or one hot start with a maximum connected load inertia of 541 Lb-Ft Sq (22.78 Kg-meter Sq) at 100% voltage, where the load torque varies with the square of the speed. Acceleration time with maximum inertia and the above load type is 51 seconds. Safe stall time at 100% voltage is 114 seconds cold, 82 seconds hot. Rotor inertia is 0.9 Lb-Ft Sq (0.04 Kg-meter Sq).

Open Circuit A-C:	0.237	Short Circuit D-C:	0.009
Short Circuit A-C:	0.014	X/R Ratio:	3.578
Stator Slots:	36	Rotor Slots:	44

Speed Torque Current Curve (First Connection, First Speed)

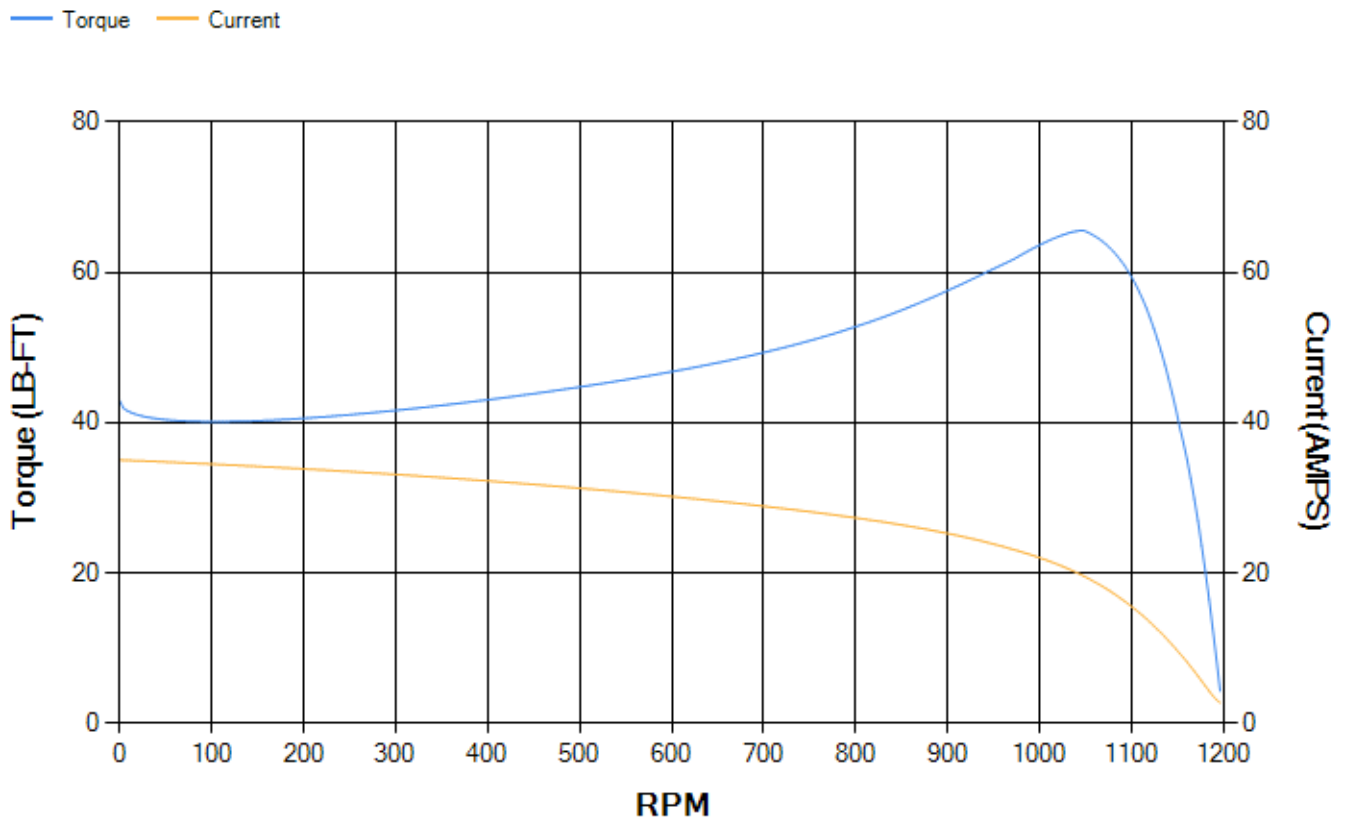

Marks:

NOTE 1: CONDUIT BOX MAY BE ASSEMBLED WITH ENTRANCE UP, DOWN OR TO EITHER SIDE.
 NOTE 2: F1 ASSEMBLY AS SHOWN. F2 ASSEMBLY CONDUIT BOX ON OPPOSITE SIDE FROM SHOWN LOCATION.
 NOTE 3: SHAFT RUNOUT WILL NOT EXCEED .001 T.I.R.
 NOTE 4: ALL DIMENSIONS ARE IN INCHES. BRACKETED DIMENSIONS ARE IN METRIC (MILLIMETERS).

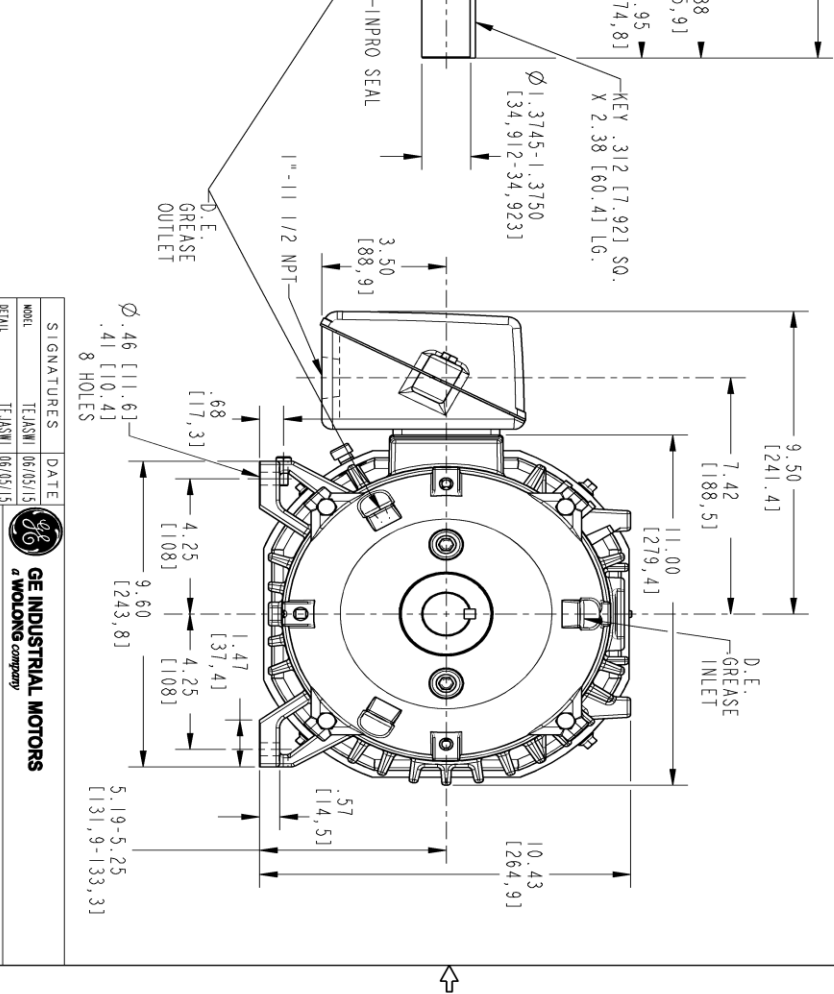
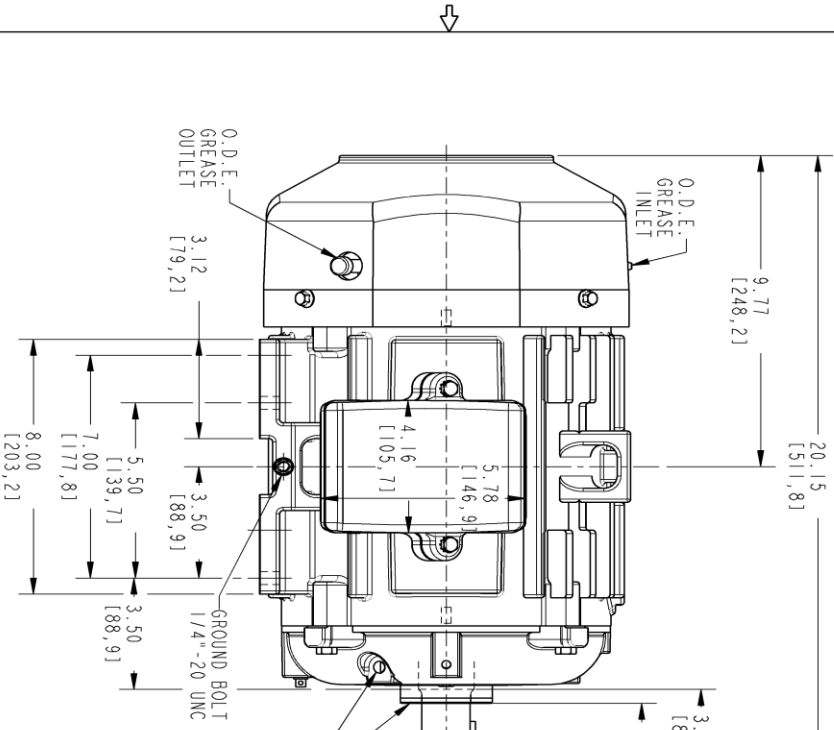

PROPRIETARY INFORMATION
 All rights reserved. This document and the information it contains is the property of the Moting Electric America LLC and/or its affiliates. It has been provided solely for transmission to the applicable recipient and any other transmission or disclosure is strictly prohibited except as expressly authorized in writing by the Moting Electric America LLC.

REV.	DESCRIPTION	DATE	APPROVED
1	AS PER ISAAC #17-0343	04/20/2017	DEEPMANI
2	REMOVED CENTER OF GRAVITY	04/27/2017	DEEPMANI
3	ISAAC# 18-0869	11/01/2018	PRAASHANTH

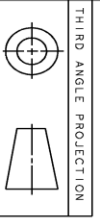

SIGNATURES	DATE
MOEL TEJASNI	06/05/19
DETAIL TEJASNI	06/05/19
CHECKED VENKAT	06/05/19
ENG'G VENKAT	06/05/19
QC	
QUALITY	
ISSUED	TEJASNI 06/05/19
SOLID MODEL: 4002B5821PAP5311	SCALE: 0.300 REF. No.: 4002B5821PAP5301

GE INDUSTRIAL MOTORS
 a WOLONG company
INDUCTION MOTOR OUTLINE
 STANDARD CONSTRUCTION FOR IEEE-941 SPEC
 FME: R219/216 T TERC
4002B5821PAP5311
 SHEET 1 OF 1

Marks:

Connection Diagram
GEM2034E-FIG1



End shield Assembly		
Part Description	DE Side Part#	ODE Side Part#
End Shield	4004D5282PB1	4004D5282SJ1
Bearing	235A2503AE01	235A2503AE01
Slinger/Inproseal	4002B5914AF3	4002B5914AG3

Fan & Fan Cover Assembly	
Part Description	Part#
Fan	159C6700G01
Fan Cover	4003C5787PA1

Conduit & Accessories Box Assembly	
Part Description	Part#
Conduit Box	4002B5721PA-G01

Mechanical Accessories	
Part Description	Part#
Brake	
Tachometer	

