



**GE INDUSTRIAL MOTORS**  
*a WOLONG company*

# Product Technical Information

June 24, 2020

Data shown is for the current revision model #. Ensure your nameplate model # matches.

<b>Model Number:</b>	<b>5KS256XAA2041C</b>
<b>Catalog Number:</b>	<b>M9515</b>
<b>Instruction Manual:</b>	GEI-56128
<b>Connection Diagram:</b>	GEM2034E-FIG1
<b>Outline Drawing:</b>	4002B5825PDP5459

Accessory Connection Diagrams			
<b>Bearing Thermocouple:</b>	None	<b>Heater:</b>	None
<b>RTD:</b>	None	<b>Thermistor:</b>	None
<b>Thermostat:</b>	None	<b>Winding Thermocouple:</b>	None
<b>Bearing RTD:</b>	None		

## Table of Contents

Specification	01
Performance Characteristics	02
Outline Drawing	03
Connection Drawing(s)	04
Spare parts	05

Marks:

<b>MODEL NUMBER:</b>	<b>5KS256XAA2041C</b>	<b>Estimated Weight:</b>	350 Lbs
<b>Outline Drawing:</b>	4002B5825PDP5459	<b>Time Rating:</b>	CONT
<b>Connection Diagram:</b>	GEM2034E-FIG1	<b>Enclosure:</b>	TEFC
<b>Instruction Book:</b>	GEI-56128	<b>Encl Construction:</b>	841
<b>Design Code:</b>	25BD1231A	<b>Ambient Max(°C):</b>	40
<b>Type:</b>	KS	<b>Alt Ambient Max(°C):</b>	--
<b>Frame:</b>	256TC	<b>Insulation Class:</b>	H
<b>Phases:</b>	3	<b>NEMA Design:</b>	B
<b>Poles:</b>	4	<b>Nominal Efficiency:</b>	93 %
<b>Output Power:</b>	20HP 14.8KW	<b>Guaranteed Efficiency:</b>	92.4 %
<b>RPM:</b>	1775	<b>3/4 Load Efficiency:</b>	93.9 %
<b>Voltage:</b>	460	<b>KVA Code:</b>	G
<b>Hertz:</b>	60	<b>Max KVAR:</b>	6.6
<b>Amps - FL:</b>	24.0	<b>Power Factor:</b>	84.0
<b>Service Factor:</b>	1.15	<b>Bearing - DE:</b>	6310ZC3
<b>Alt Service Factor:</b>	--	<b>Bearing - ODE:</b>	6309ZC3

Enclosure is Totally Enclosed Fan-Cooled

---

Stamped Nameplate Notes:

IEEE-STD-841-2009  
 DE BRG 50BC03JP30 ODE BRG 45BC03JP30  
 STAMP NP249A5564P051 AS BELOW:  
 MODEL:5KS256XAA2041C S/N: XXX  
 CSA CERTIFIED CSA09.2216219 FOR EX NA IIC 200C GC  
 CL 1 ZONE2 AEX NA IIC 200C;CL 1 DIV2 GRP ABCD 200C  
 IN -25C <= AMB <= 40C, 1.0 SF ON SINE-WAVE PWR  
 SURF TEMP 200C AT 1.15SF ON SINE-WAVE PWR  
 OR 200C VT OR 200C CT OR 200C CHP PWM CONTROL  
 ALTERNATE RATING FOR PWM CONTROL 1.0SF 40C AMB  
 VT 0 - 60 HZ, CT 6-60HZ, CHP 60-90HZ.



**Additional Information:**

4P - T EXTN  
C/BOX 137 CU IN-1.25 NPT  
"C" FACE AT DE ENDSHIELD ROUND FRAME  
VERTICAL MOUNT SHAFT DOWN WITH DRIPCOVER  
PAINTED FRAME ID & SHAFT,  
FAN COVER INSIDE & ODE E/S OUTSIDE  
ROUTINE AND 5 POINT VIBRATION TESTS INCL IN C/BOX  
INPRO SEAL BOTH ENDS  
E/SHLD GROUND STUD MTD ON DE C/BOX SIDE NEAR FOOT  
ROTATE D.E. E/SHIELD 90 DEG. PER OUTLINE  
SHAFT RUNOUT LIMIT .001" TIR  
COPPER WASHER UNDER HEADS OF BEARING CAP BOLTS  
APPLY TITE-SEAL (A50CD427A) ON BEARING CAP SCREWS, RABBETS,  
AND PLUG THREADS  
OIL RESISTANT SLEEVING ON LEADS



**Performance Characteristics**

1st Winding 1st Connection

**Design: 25BD1231A**

**Marks:**

LOAD %	125.0	115.0	100.0	75.0	50.0	25.0	0.0
% EFF	92.54	92.92	93.59	93.87	93.62	90.86	0.00
% PF	85.7	85.21	83.96	79.72	70.03	47.68	4.28
AMPS	29.5	27.19	23.82	18.76	14.27	10.8	9.18

<b>TORQ(FL)#FT</b>	59.15	<b>TORQ(LR)%FL</b>	215.43	<b>TORQ(BD)%FL</b>	269.28
<b>AMPS(LR)</b>	142.25	<b>PF AT START</b>	0.45		

This motor is capable of two cold or one hot start with a maximum connected load inertia of 726 Lb-Ft Sq (30.56 Kg-meter Sq)at 100% voltage, where the load torque varies with the square of the speed. Acceleration time with maximum inertia and the above load type is 45 seconds. Safe stall time at 100% voltage is 98 seconds cold, 64 seconds hot. Rotor inertia is 3.01 Lb-Ft Sq (0.13 Kg-meter Sq).

<b>Open Circuit A-C:</b>	0.48	<b>Short Circuit D-C:</b>	0.014
<b>Short Circuit A-C:</b>	0.024	<b>X/R Ratio:</b>	5.314
<b>Stator Slots:</b>	48	<b>Rotor Slots:</b>	40

**Speed Torque Current Curve (First Connection, First Speed)**

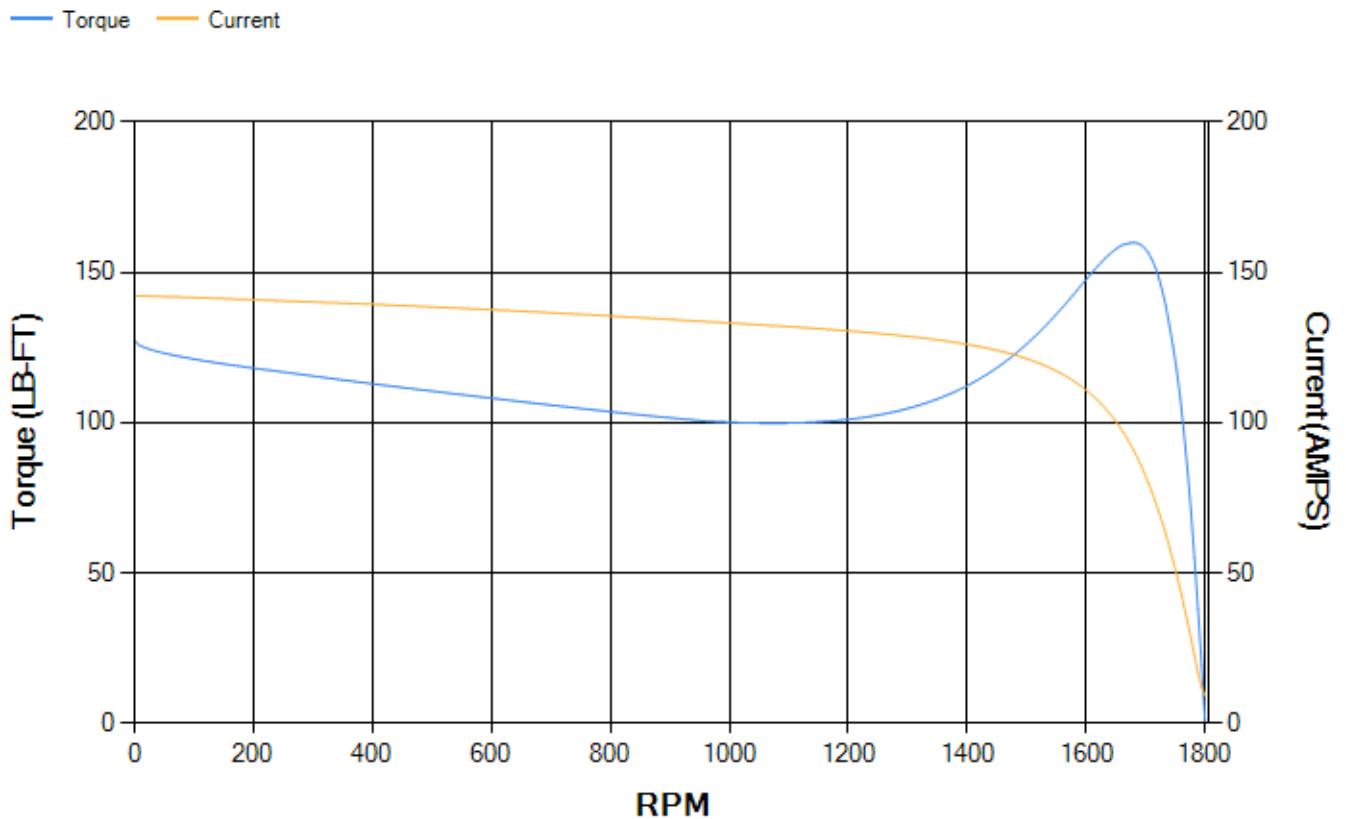

Marks:

NOTE 1: CONDUIT BOX MAY BE ASSEMBLED WITH ENTRANCE UP, DOWN OR TO EITHER SIDE.  
 NOTE 2: F1 ASSEMBLY AS SHOWN. F2 ASSEMBLY CONDUIT BOX ON OPPOSITE SIDE FROM SHOWN LOCATION.  
 NOTE 3: MOUNTING SURFACES TO BE SQUARE AND CONCENTRIC WITH SHAFT WITHIN .004 T.I.R.  
 NOTE 4: SHAFT RUNOUT WILL NOT EXCEED .001 T.I.R.  
 NOTE 5: DE ENDSHIELD ROTATED 90° COUNTER CLOCKWISE  
 NOTE 6: ALL DIMENSIONS ARE IN INCHES, BRACKETED DIMENSIONS ARE IN METRIC (MILLIMETERS)

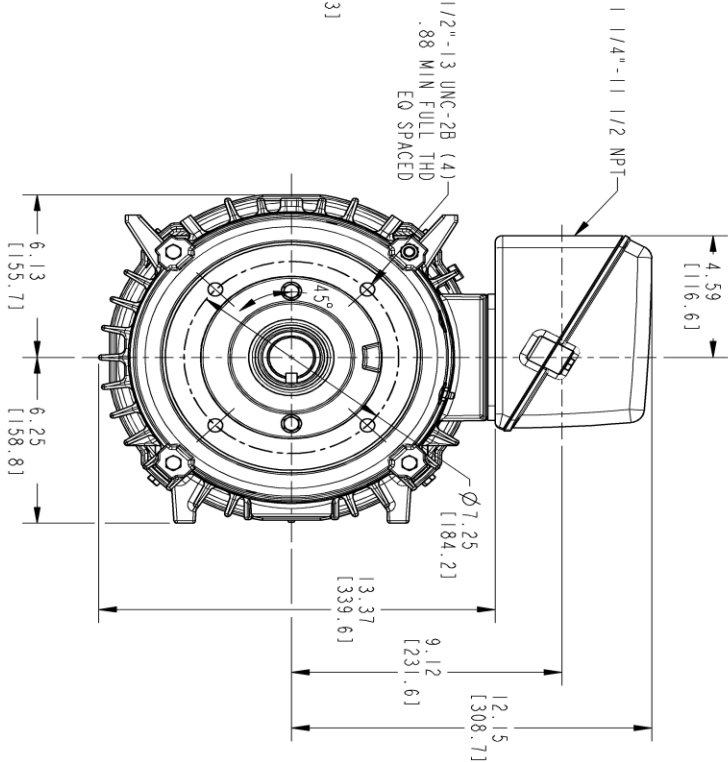
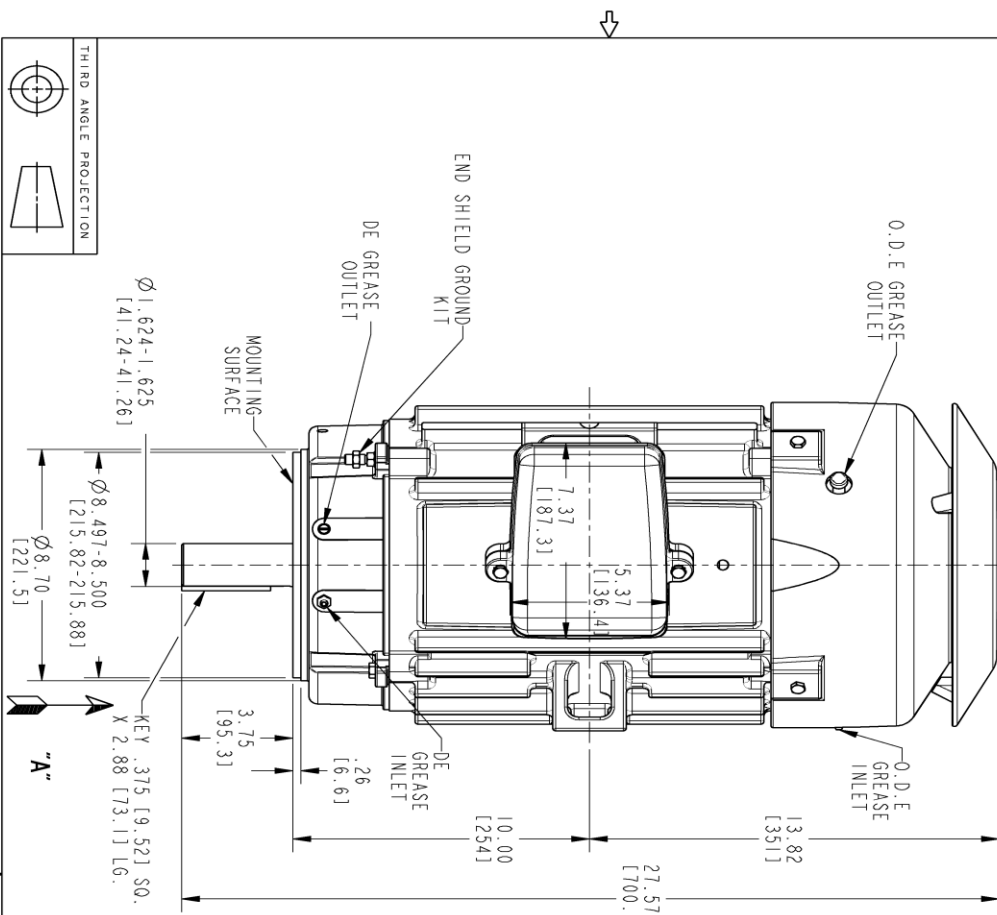

VIEW AT "A"

PROPRIETARY INFORMATION  
 © COPYRIGHT 2018 Wolog Electric America LLC AND/OR ITS AFFILIATES  
 All rights reserved. This document and the information it contains is the property of Wolog Electric America LLC and/or its affiliates. It has been provided solely for the use of the recipient for the specific project and for the specific application. No other use, reproduction, distribution, or disclosure of this information is strictly prohibited except as expressly authorized in writing by Wolog Electric America LLC.

REV.	DESCRIPTION	DATE	APPROVED
1	ISAC# 18-0869	11/05/18	PRASHANTH

SIGNATURES	DATE	<p><b>GE INDUSTRIAL MOTORS</b>                  a Wolog company</p>
MODEL	03/03/2017	
DETAIL	03/03/2017	
CREATED	03/03/2017	
DATE	03/03/2017	TITLE
ENG	03/03/2017	INDUCTION MOTOR OUTLINE
ISSUED	03/03/2017	137 CU. IN. DRP COVER, EXT
SOLID MODEL	4002B5825PDP5459	SCALE: 0.250
		REF. No.: 4002B5825PDP5310
		REV
		001

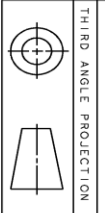

**Marks:**

**Connection Diagram**  
**GEM2034E-FIG1**



End shield Assembly		
Part Description	DE Side Part#	ODE Side Part#
End Shield	128D6106RF1	4004D5283SE1
Bearing	235A2508EC01	235A2507EB01
Slinger/Inproseal	4002B5914GF4	4002B5914AG4

Fan & Fan Cover Assembly	
Part Description	Part#
Fan	159C6700G02
Fan Cover	4003C5525BN-G01

Conduit & Accessories Box Assembly	
Part Description	Part#
Conduit Box	4002B5728PA-G04

Mechanical Accessories	
Part Description	Part#
Brake	
Tachometer	

