



GE INDUSTRIAL MOTORS
a **WOLONG** company

Product Technical Information

June 24, 2020

Data shown is for the current revision model #. Ensure your nameplate model # matches.

Model Number:	5KS284XAA2002D1
Catalog Number:	M9519
Instruction Manual:	GEI-56128
Connection Diagram:	GEM2034E-FIG7
Outline Drawing:	4002B5828PDP5389

Accessory Connection Diagrams

Bearing Thermocouple:	None	Heater:	None
RTD:	None	Thermistor:	None
Thermostat:	None	Winding Thermocouple:	None
Bearing RTD:	None		

Table of Contents

Specification	01
Performance Characteristics	02
Outline Drawing	03
Connection Drawing(s)	04
Spare parts	05

Marks:

MODEL NUMBER:	5KS284XAA2002D1	Estimated Weight:	460 Lbs
Outline Drawing:	4002B5828PDP5389	Time Rating:	CONT
Connection Diagram:	GEM2034E-FIG7	Enclosure:	TEFC
Instruction Book:	GEI-56128	Encl Construction:	841
Design Code:	28BD1162A	Ambient Max(°C):	40
Type:	KS	Alt Ambient Max(°C):	--
Frame:	284TC	Insulation Class:	H
Phases:	3	NEMA Design:	B
Poles:	4	Nominal Efficiency:	93.6 %
Output Power:	25HP 18.5KW	Guaranteed Efficiency:	93.0 %
RPM:	1780	3/4 Load Efficiency:	94.1 %
Voltage:	460	KVA Code:	G
Hertz:	60	Max KVAR:	7.0
Amps - FL:	29.1	Power Factor:	86.0
Service Factor:	1.15	Bearing - DE:	6310ZC3
Alt Service Factor:	--	Bearing - ODE:	6310ZC3

Enclosure is Totally Enclosed Fan-Cooled

Stamped Nameplate Notes:

IEEE-STD-841-2009
 DE BRG 50BC03JP30 ODE BRG 50BC03JP30
 STAMP NP249A5564P051 AS BELOW:
 MODEL:5KS284XAA2002D1 S/N: XXX
 CSA CERTIFIED CSA09.2216219 FOR EX NA IIC 200C GC
 CL 1 ZONE2 AEX NA IIC 200C;CL 1 DIV2 GRP ABCD 200C
 IN -25C <= AMB <= 40C, 1.0 SF ON SINE-WAVE PWR
 SURF TEMP 200C AT 1.15SF ON SINE-WAVE PWR
 OR 200C VT OR 200C CT OR 200C CHP PWM CONTROL
 ALTERNATE RATING FOR PWM CONTROL 1.0SF 40C AMB
 VT 0 - 60 HZ, CT 3-60HZ, CHP 60-90HZ.



Additional Information:

4P - T EXTN
C/BOX 137 CU IN-1.50 NPT
"C" FACE AT DE ENDSHIELD ROUND FRAME
VERTICAL MOUNT SHAFT DOWN WITH DRIPCOVER
PAINTED FRAME ID & SHAFT,
FAN COVER INSIDE & ODE E/S OUTSIDE
ROUTINE AND 5 POINT VIBRATION TESTS INCL IN C/BOX
INPRO SEAL BOTH ENDS
E/SHLD GROUND STUD MTD ON DE C/BOX SIDE NEAR FOOT
ROTATE D.E. E/SHIELD 90 DEG. PER OUTLINE
SHAFT RUNOUT LIMIT .0015" TIR
COPPER WASHER UNDER HEADS OF BEARING CAP BOLTS
APPLY TITE-SEAL (A50CD427A) ON BEARING CAP SCREWS, RABBETS,
AND PLUG THREADS
OIL RESISTANT SLEEVING ON LEADS



Performance Characteristics

1st Winding 1st Connection

Design: 28BD1162A

Marks:

LOAD %	125.0	115.0	100.0	75.0	50.0	25.0	0.0
% EFF	92.51	92.93	93.67	94.08	94.02	91.68	0.00
% PF	86.95	86.71	85.9	82.65	74.39	52.87	4.42
AMPS	36.36	33.39	29.06	22.57	16.73	12.07	9.81

TORQ(FL)#FT	73.83	TORQ(LR)%FL	181.27	TORQ(BD)%FL	286.95
AMPS(LR)	178.14	PF AT START	0.38		

This motor is capable of two cold or one hot start with a maximum connected load inertia of 887 Lb-Ft Sq (37.34 Kg-meter Sq)at 100% voltage, where the load torque varies with the square of the speed. Acceleration time with maximum inertia and the above load type is 56 seconds. Safe stall time at 100% voltage is 100 seconds cold, 67 seconds hot. Rotor inertia is 4.88 Lb-Ft Sq (0.21 Kg-meter Sq).

Open Circuit A-C:	0.626	Short Circuit D-C:	0.016
Short Circuit A-C:	0.028	X/R Ratio:	5.887
Stator Slots:	48	Rotor Slots:	40

Speed Torque Current Curve (First Connection, First Speed)

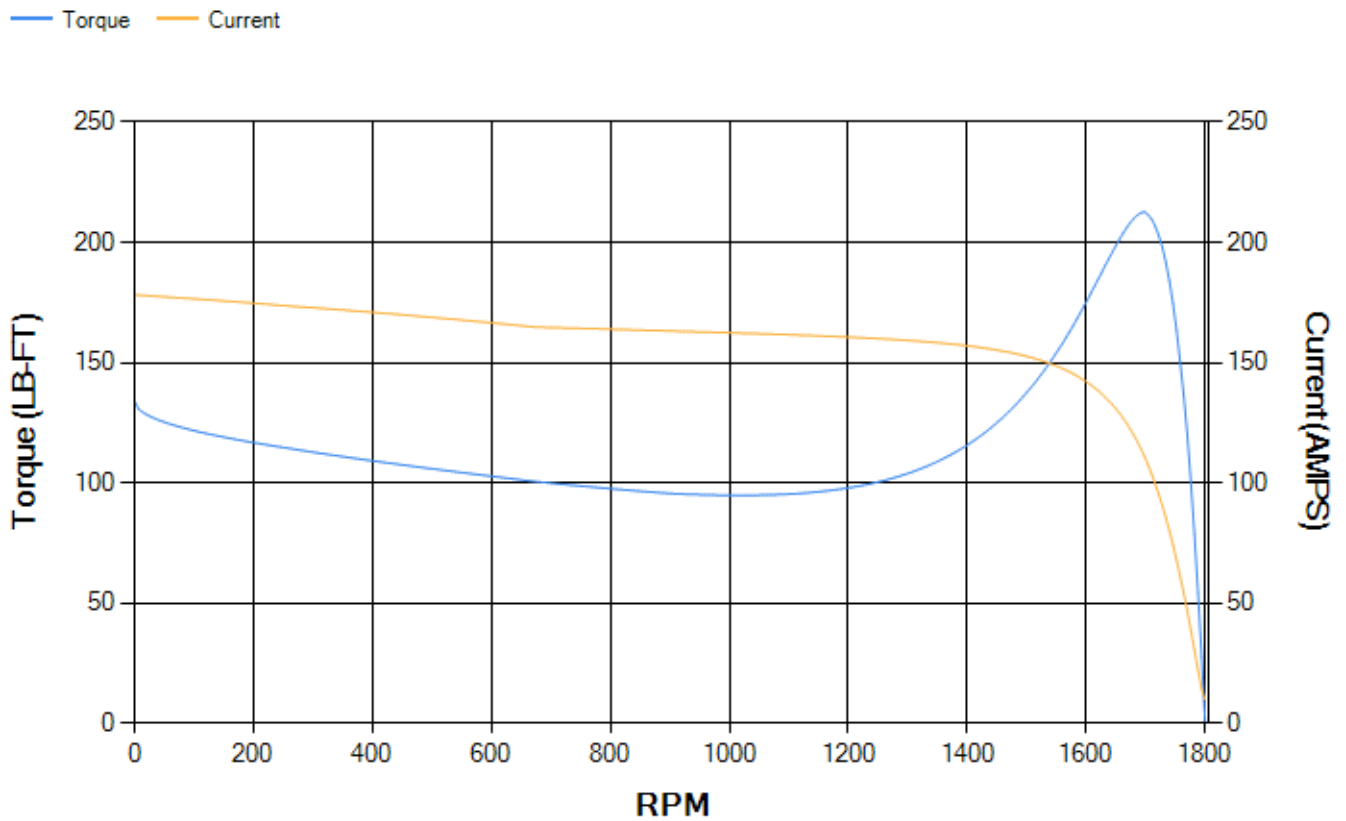

Marks:

- NOTE 1: CONDUIT BOX MAY BE ASSEMBLED WITH ENTRANCE UP, DOWN OR TO EITHER SIDE.
- NOTE 2: F1 ASSEMBLY AS SHOWN, F2 ASSEMBLY CONDUIT BOX ON OPPOSITE SIDE FROM SHOWN LOCATION.
- NOTE 3: MOUNTING SURFACES TO BE SQUARE AND CONCENTRIC WITH SHAFT WITHIN .004 T.I.R.
- NOTE 4: SHAFT RUNOUT WILL NOT EXCEED .0015 T.I.R.
- NOTE 5: DE ENDSHIELD ROTATED 90° COUNTER CLOCKWISE.

PROPRIETARY INFORMATION
 © COPYRIGHT 2018 Wolog Electric America LLC AND/OR ITS AFFILIATES
 All rights reserved. This document and the information it contains is the property of the Wolog Electric America LLC and/or its affiliates. It has been provided solely for transmission for design and engineering purposes. No other use, reproduction, or distribution is strictly prohibited except as expressly authorized in writing by the Wolog Electric America LLC.

REVISIONS			
REV.	DESCRIPTION	DATE	APPROVED
1	ISAAC# 18-0869	SNEDEVI 11/08/18	PRASHANTH

SIZE DRAWING NO. **4002B5828PDP5389** REV. **001** SHEET **1**

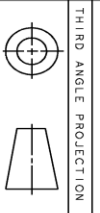
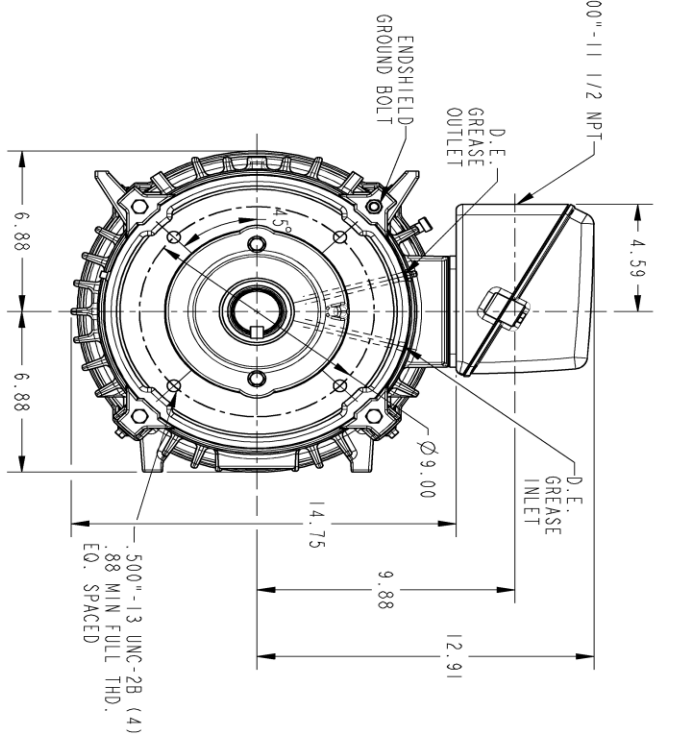
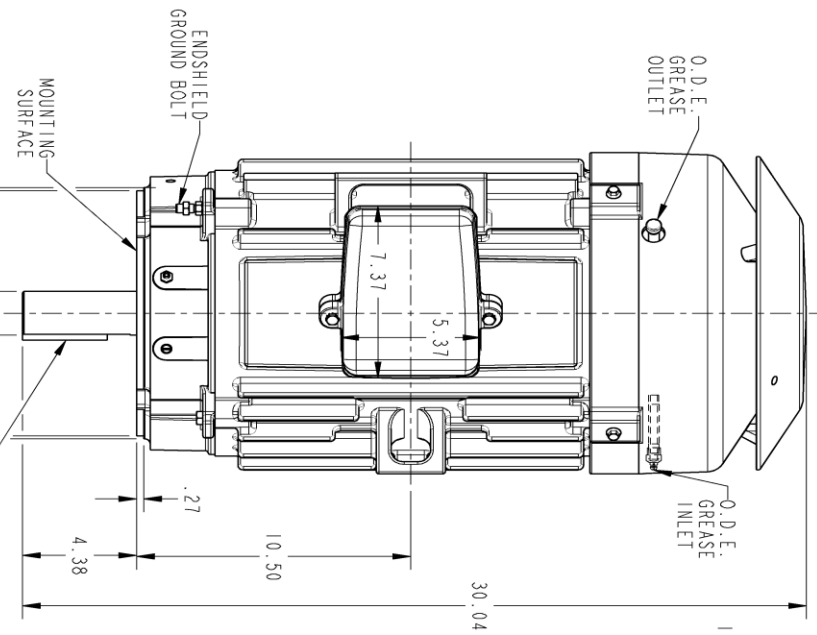

SIGNATURES	DATE	TITLE
LAXMIKANTH	03/06/2017	INDUCTION MOTOR OUTLINE
LAXMIKANTH	03/06/2017	IEEE-841 SPEC AND DRIP COVER (0.50\"/>

QUALITY: LAXMIKANTH 03/06/2017
 ISSUE: LAXMIKANTH 03/06/2017
 SCALE: 0.220 REF. No.: 4002B5828PDP5310



4002B5828PDP5389 REV. **001**

Marks:

Connection Diagram
GEM2034E-FIG7



End shield Assembly		
Part Description	DE Side Part#	ODE Side Part#
End Shield	128D6206RF1	4004D5284SE1
Bearing	235A2508EC01	235A2508EC01
Slinger/Inproseal	4002B5914GF4	4002B5914AG5

Fan & Fan Cover Assembly	
Part Description	Part#
Fan	159C6700G02
Fan Cover	4003C5528BN-G01

Conduit & Accessories Box Assembly	
Part Description	Part#
Conduit Box	4002B5728PA-G01

Mechanical Accessories	
Part Description	Part#
Brake	
Tachometer	

