



GE INDUSTRIAL MOTORS
a **WOLONG** company

Product Technical Information

February 15, 2021

Data shown is for the current revision model #. Ensure your nameplate model # matches.

Model Number:	5KS444SAA114D11
Catalog Number:	M9538
Instruction Manual:	GEI-56128
Connection Diagram:	GEM2034E-FIG7
Outline Drawing:	239C6H00AH

Accessory Connection Diagrams

Bearing Thermocouple:	None	Heater:	None
RTD:	None	Thermistor:	None
Thermostat:	None	Winding Thermocouple:	None
Bearing RTD:	None		

Table of Contents

Specification	01
Performance Characteristics	02
Outline Drawing	03
Connection Drawing(s)	04
Spare parts	05

Marks:

MODEL NUMBER:	5KS444SAA114D11	Estimated Weight:	2020 Lbs
Outline Drawing:	239C6H00AH	Time Rating:	CONT
Connection Diagram:	GEM2034E-FIG7	Enclosure:	TEFC
Instruction Book:	GEI-56128	Encl Construction:	841
Design Code:	44BD0197B	Ambient Max(°C):	40
Type:	KS	Alt Ambient Max(°C):	--
Frame:	444TS	Insulation Class:	H
Phases:	3	NEMA Design:	B
Poles:	2	Nominal Efficiency:	95.0 %
Output Power:	125HP 92.5KW	Guaranteed Efficiency:	94.5 %
RPM:	3580	3/4 Load Efficiency:	--
Voltage:	575	KVA Code:	G
Hertz:	60	Max KVAR:	20.5
Amps - FL:	108.0	Power Factor:	91.5
Service Factor:	1.15	Bearing - DE:	6314ZC3
Alt Service Factor:	--	Bearing - ODE:	6314ZC3

Enclosure is Totally Enclosed Fan-Cooled

Stamped Nameplate Notes:

EXCEPTION TO IEEE-STD-841-2009: SOUND POWER 92 DBA
 DE BRG 70BC03JP30, ODE BRG 70BC03JP30
 STAMP NP249A5564P051 AS BELOW:
 MODEL:5KS444SAA114D11 S/N: XXX
 CSA CERTIFIED CSA09.2216219 FOR EX NA IIC 200 C GC
 CL 1 ZONE2 AEX NA IIC 200C;CL 1 DIV2 GRP ABCD 200C
 IN -40C <= AMB <= 40C, 1.0 SF ON SINE-WAVE PWR
 SURF TEMP 200C AT 1.15SF ON SINE-WAVE PWR
 OR 200C VT OR 200C CT OR ---C CHP PWM CONTROL
 ALTERNATE RATING FOR PWM CONTROL 1.0SF 40C AMB
 VT 0 - 60 HZ, CT 3 - 60 HZ, CHP -- HZ.



Additional Information:

2P - TS EXTN
PAINTED FRAME ID & SHAFT,
FAN COVER INSIDE & ODE E/S OUTSIDE
C/BOX 700 CU IN - 3.00" NPT
OIL RESISTANT SLEEVING ON LEADS
.0015" TIR SHAFT RUNOUT
ROUTINE TEST REPORT AND 5 POINT VIBRATION TEST
REPORT INCLUDED IN C/B
GROUND PAD
F1 MOUNTING



Performance Characteristics

1st Winding 1st Connection

Design: 44BD0197B

Marks:

LOAD %	125.0	115.0	100.0	75.0	50.0	25.0	0.0
% EFF	94.75	94.89	95.22	94.94	94.11	90.59	0.00
% PF	90.99	91.22	91.29	90.4	86.69	72.34	9.65
AMPS	135.7	124.36	107.68	81.78	57.36	35.71	22.84

TORQ(FL)#FT	183.41	TORQ(LR)%FL	147.97	TORQ(BD)%FL	254
AMPS(LR)	665.64	PF AT START	0.22		

This motor is capable of two cold or one hot start with a maximum connected load inertia of 566 Lb-Ft Sq (23.83 Kg-meter Sq)at 100% voltage, where the load torque varies with the square of the speed. Acceleration time with maximum inertia and the above load type is 47 seconds. Safe stall time at 100% voltage is 93 seconds cold, 57 seconds hot. Rotor inertia is 31.01 Lb-Ft Sq (1.31 Kg-meter Sq).

Open Circuit A-C:	2.086	Short Circuit D-C:	0.039
Short Circuit A-C:	0.075	X/R Ratio:	14.812
Stator Slots:	48	Rotor Slots:	38

Speed Torque Current Curve (First Connection, First Speed)

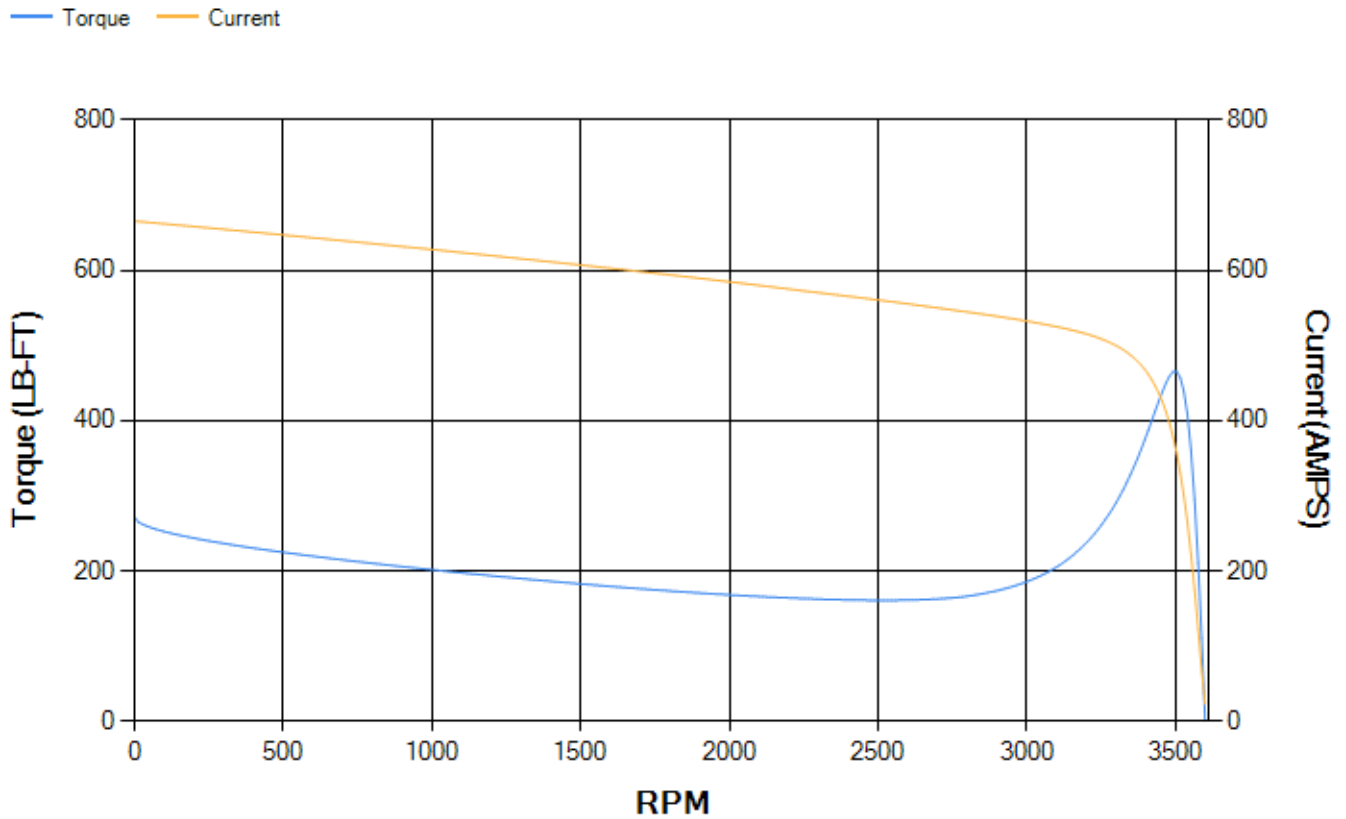

Marks:

SOLID MODEL: 239C6H00AH



THIRD ANGLE PROJECTION

A

B

C

D

NOTES:

1. CONDUIT BOX MAY BE PLACED WITH THE ENTRANCE DOWN, UP OR ON EITHER SIDE.
2. F-1 ASSEMBLY AS SHOWN.
3. F-2 ASSEMBLY HAS CONDUIT BOX ON OPPOSITE SIDE.
4. BRACKETED DIMENSIONS ARE METRIC (MILLIMETERS).

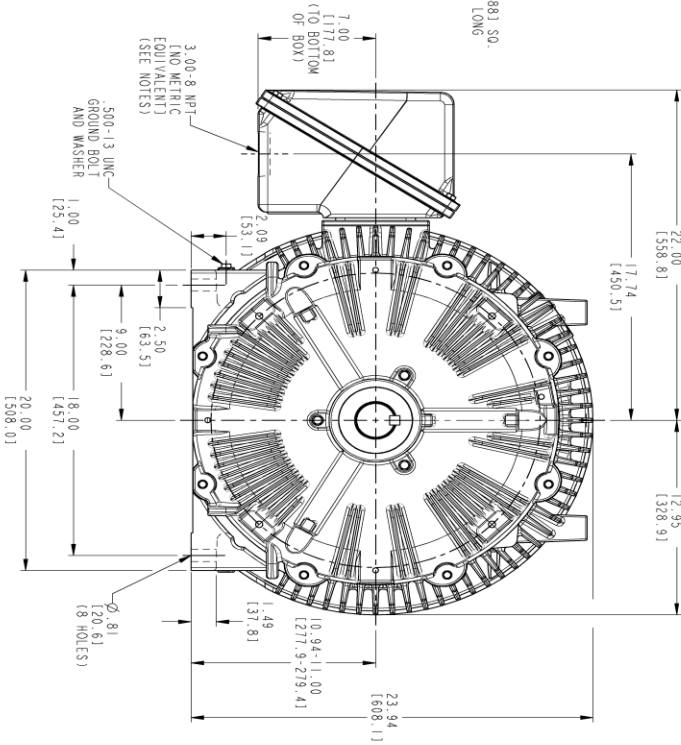
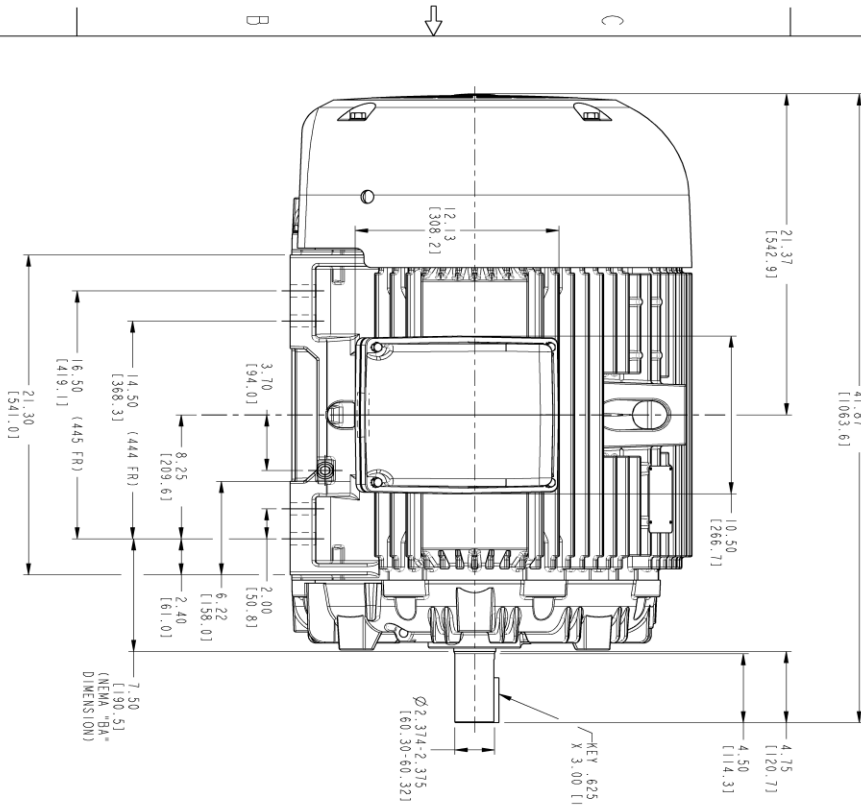

© COPYRIGHT 2021 GEORGE A. ERICKSON, ELECTRIC COMPANY, ALL RIGHTS RESERVED. ALL OTHER PATENTS, TRADEMARKS AND SERVICE MARKS ARE THE PROPERTY OF THEIR RESPECTIVE OWNERS. GEORGE A. ERICKSON, ELECTRIC COMPANY, 10000 W. 10TH AVENUE, DENVER, CO 80231. THIS DRAWING IS THE PROPERTY OF GEORGE A. ERICKSON, ELECTRIC COMPANY. IT IS TO BE USED ONLY FOR THE PROJECT AND QUANTITY SPECIFIED IN THE ORDER. IT IS NOT TO BE REPRODUCED OR TRANSMITTED IN ANY FORM OR BY ANY MEANS, ELECTRONIC OR MECHANICAL, INCLUDING PHOTOCOPYING, RECORDING, OR BY ANY INFORMATION STORAGE AND RETRIEVAL SYSTEM, WITHOUT THE WRITTEN PERMISSION OF GEORGE A. ERICKSON, ELECTRIC COMPANY.

REV.	DESCRIPTION	DATE	APPROVED

SIGNATURES	DATE	DATE	DATE
MODEL: BHARTH 07/18/18	07/18/18	07/18/18	07/18/18
CHECKED: VIJAY 07/18/18	07/18/18	07/18/18	07/18/18
DESIGN: SUDHAR 07/18/18	07/18/18	07/18/18	07/18/18
QUALITY: BHARTH 07/18/18	07/18/18	07/18/18	07/18/18

GE POWER CONVERSION

OUTLINE

444/445TS TEFC

700 CU IN CONDUIT BOX, GROUND PAD

239C6H00AH

SCALE: 0.200

REF: 239C6H00AA

DISTRIBUTION: MMP

SHEET 1 OF 1

Marks:

Connection Diagram
GEM2034E-FIG7



End shield Assembly		
Part Description	DE Side Part#	ODE Side Part#
End Shield	115E4354AA1	115E4354LL1
Bearing	235A2516AC01	235A2516AC01
Slinger/Inproseal	149C4399G05	149C4399G05

Fan & Fan Cover Assembly	
Part Description	Part#
Fan	159C7100AA1
Fan Cover	128D6841AA1

Conduit & Accessories Box Assembly	
Part Description	Part#
Conduit Box	118D4408AD2

Mechanical Accessories	
Part Description	Part#
Brake	
Tachometer	

