



GE INDUSTRIAL MOTORS
a **WOLONG** company

Product Technical Information

June 24, 2020

Data shown is for the current revision model #. Ensure your nameplate model # matches.

Model Number:	5KS254XAA2102C
Catalog Number:	M9552
Instruction Manual:	GEI-56128
Connection Diagram:	GEM2034E-FIG7
Outline Drawing:	4002B5825PBP5477

Accessory Connection Diagrams

Bearing Thermocouple:	None	Heater:	None
RTD:	None	Thermistor:	None
Thermostat:	None	Winding Thermocouple:	None
Bearing RTD:	None		

Table of Contents

Specification	01
Performance Characteristics	02
Outline Drawing	03
Connection Drawing(s)	04
Spare parts	05

Marks:

MODEL NUMBER:	5KS254XAA2102C	Estimated Weight:	315 Lbs
Outline Drawing:	4002B5825PBP5477	Time Rating:	CONT
Connection Diagram:	GEM2034E-FIG7	Enclosure:	TEFC
Instruction Book:	GEI-56128	Encl Construction:	841
Design Code:	25BD1258B	Ambient Max(°C):	40
Type:	KS	Alt Ambient Max(°C):	--
Frame:	254TC	Insulation Class:	H
Phases:	3	NEMA Design:	B
Poles:	4	Nominal Efficiency:	92.4 %
Output Power:	15HP 11.1KW	Guaranteed Efficiency:	91.7 %
RPM:	1775	3/4 Load Efficiency:	93.3 %
Voltage:	575	KVA Code:	G
Hertz:	60	Max KVAR:	5.3
Amps - FL:	14.6	Power Factor:	83.0
Service Factor:	1.15	Bearing - DE:	6310ZC3
Alt Service Factor:	--	Bearing - ODE:	6309ZC3

Enclosure is Totally Enclosed Fan-Cooled

Stamped Nameplate Notes:

IEEE-STD-841-2009
 DE BRG 50BC03JP30 ODE BRG 45BC03JP30
 STAMP NP249A5564P051 AS BELOW:
 MODEL:5KS254XAA2102C S/N: XXX
 CSA CERTIFIED CSA09.2216219 FOR EX NA IIC 200C GC
 CL 1 ZONE2 AEX NA IIC 200C;CL 1 DIV2 GRP ABCD 200C
 IN -25C <= AMB <= 40C, 1.0 SF ON SINE-WAVE PWR
 SURF TEMP 200C AT 1.15SF ON SINE-WAVE PWR
 OR 200C VT OR 200C CT OR 200C CHP PWM CONTROL
 ALTERNATE RATING FOR PWM CONTROL 1.0SF 40C AMB
 VT 0 - 60 HZ, CT 3-60HZ, CHP 60-90HZ.



Additional Information:

4P - T EXTN
STANDARD FLOOR MOUNT
C/BOX 137 CU IN-1.25 NPT
F1 CONDUIT BOX MOUNTING
"C" FACE AT DE ENDSHIELD
PAINTED FRAME ID & SHAFT,
FAN COVER INSIDE & ODE E/S OUTSIDE
ROUTINE AND 5 POINT VIBRATION TESTS INCL IN C/BOX
INPRO SEAL BOTH ENDS
GROUND SCREW ON FRAME
ROTATE D.E. E/SHIELD 90 DEG. PER OUTLINE
SHAFT RUNOUT LIMIT .001" TIR
COPPER WASHER UNDER HEADS OF BEARING CAP BOLTS
APPLY TITE-SEAL (A50CD427A) ON BEARING CAP SCREWS, RABBETS,
AND PLUG THREADS
OIL RESISTANT SLEEVING ON LEADS



Performance Characteristics

1st Winding 1st Connection

Design: 25BD1258B

Marks:

LOAD %	125.0	115.0	100.0	75.0	50.0	25.0	0.0
% EFF	92.1	92.46	93.12	93.33	92.92	89.66	0.00
% PF	85.01	84.41	82.97	78.27	68.01	45.58	4.61
AMPS	17.93	16.55	14.54	11.53	8.89	6.87	5.94

TORQ(FL)#FT	44.36	TORQ(LR)%FL	206.93	TORQ(BD)%FL	269.81
AMPS(LR)	85.62	PF AT START	0.45		

This motor is capable of two cold or one hot start with a maximum connected load inertia of 567 Lb-Ft Sq (23.87 Kg-meter Sq) at 100% voltage, where the load torque varies with the square of the speed. Acceleration time with maximum inertia and the above load type is 48 seconds. Safe stall time at 100% voltage is 106 seconds cold, 72 seconds hot. Rotor inertia is 2.29 Lb-Ft Sq (0.1 Kg-meter Sq).

Open Circuit A-C:	0.456	Short Circuit D-C:	0.013
Short Circuit A-C:	0.025	X/R Ratio:	4.97
Stator Slots:	48	Rotor Slots:	40

Speed Torque Current Curve (First Connection, First Speed)

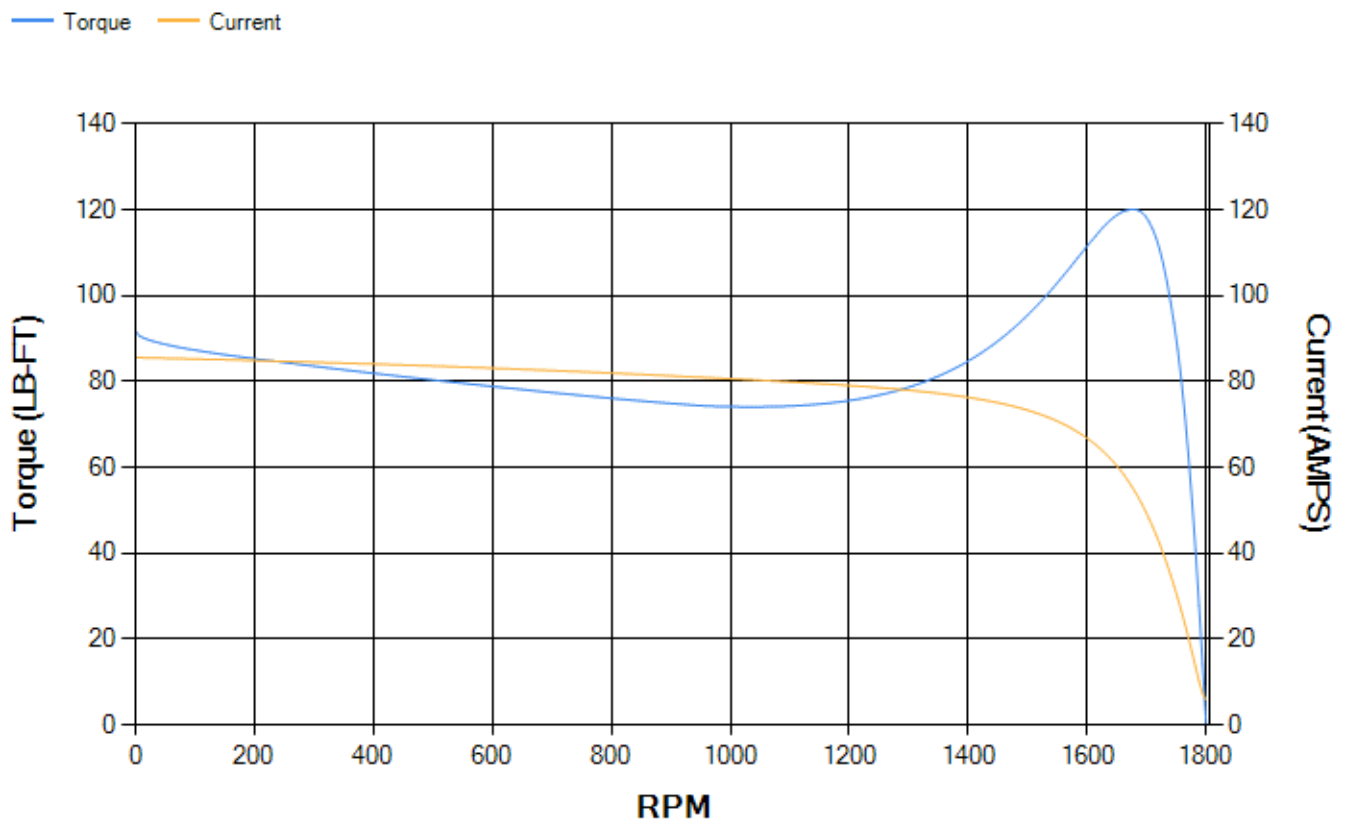

Marks:

- NOTE 1: CONDUIT BOX MAY BE ASSEMBLED WITH ENTRANCE UP, DOWN OR TO EITHER SIDE.
- NOTE 2: F1 ASSEMBLY AS SHOWN. F2 ASSEMBLY CONDUIT BOX ON OPPOSITE SIDE FROM SHOWN LOCATION.
- NOTE 3: MOUNTING SURFACES WILL BE SQUARE AND CONCENTRIC WITH SHAFT WITHIN .004 T.I.R.
- NOTE 4: SHAFT RUNOUT WILL NOT EXCEED .001 T.I.R.
- NOTE 5: DE ENDSHIELD ROTATED 90° COUNTER CLOCKWISE
- NOTE 6: ALL DIMENSIONS ARE IN INCHES, BRACKETED DIMENSIONS ARE IN METRIC (MILLIMETERS)

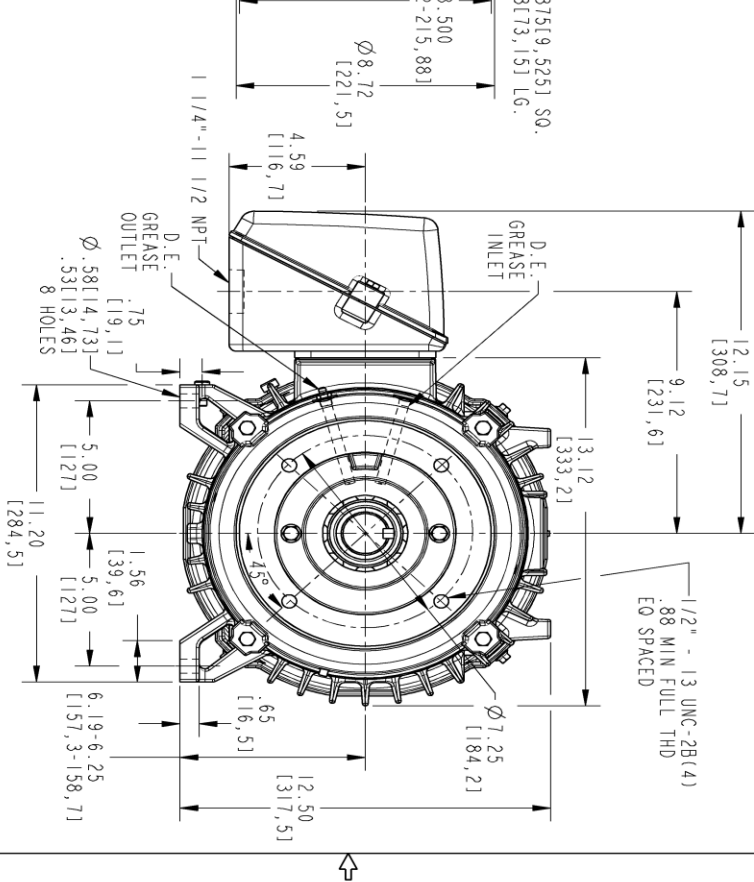
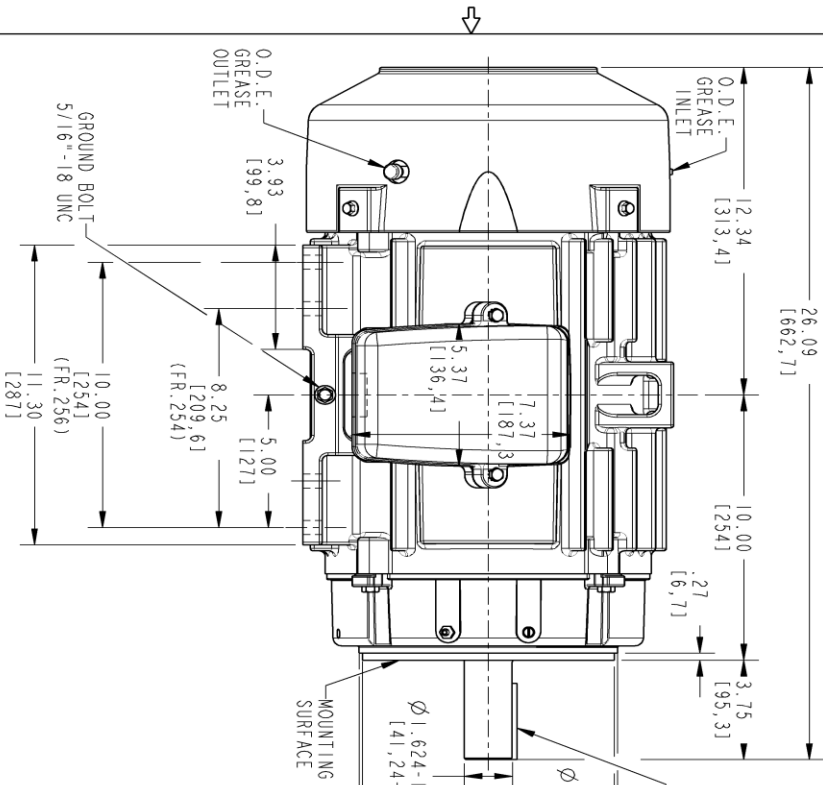

PROPRIETARY INFORMATION
 © COPYRIGHT 2018 Wolog Electric America LLC AND/OR ITS AFFILIATES
 All rights reserved. This document and the information it contains is the property of Wolog Electric America LLC and/or its affiliates. It has been provided solely for transmission to the recipient for the specific project identified in the drawing. It is not to be distributed, copied, or used for any other project without the express written consent of Wolog Electric America LLC. Any other use is strictly prohibited except as expressly authorized in writing by Wolog Electric America LLC.

REV.	DESCRIPTION	DATE	APPROVED
1	ISAAC# 18-0869	11/05/18	PRASHANTH
2	ISAAC# 18-1086	12/26/18	KARTHIK

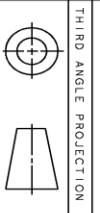

THIRD ANGLE PROJECTION

SIGNATURES	DATE	TITLE
LAKHAKANTH	03/03/2017	INDUCTION MOTOR OUTLINE
LAKHAKANTH	03/03/2017	INDUCTION MOTOR OUTLINE
PYUSH	03/03/2017	INDUCTION MOTOR OUTLINE
PYUSH	03/03/2017	INDUCTION MOTOR OUTLINE
LAKHAKANTH	03/03/2017	INDUCTION MOTOR OUTLINE

GE INDUSTRIAL MOTORS
 a Wolog company

IEEE941 SPEC. "C" FACE AT DRIVE END (850° HABBET)
 137 CUIN. FR. 254/256TC TFFC

SCALE: 0.250 REF. No.: 4002B5825PBP5477

4002B5825PBP5477

SIZE DRAWING NO. 4002B5825PBP5477 002

SHEET 1

Marks:

Connection Diagram
GEM2034E-FIG7



End shield Assembly		
Part Description	DE Side Part#	ODE Side Part#
End Shield	128D6106RF1	4004D5283SE1
Bearing	235A2508EC01	235A2507EB01
Slinger/Inproseal	4002B5914GF4	4002B5914AG4

Fan & Fan Cover Assembly	
Part Description	Part#
Fan	159C6700G02
Fan Cover	4003C5788PA1

Conduit & Accessories Box Assembly	
Part Description	Part#
Conduit Box	4002B5728PA-G04

Mechanical Accessories	
Part Description	Part#
Brake	
Tachometer	

