



GE INDUSTRIAL MOTORS
a **WOLONG** company

Product Technical Information

June 24, 2020

Data shown is for the current revision model #. Ensure your nameplate model # matches.

Model Number:	5KS286XAA181C
Catalog Number:	M9557
Instruction Manual:	GEI-56128
Connection Diagram:	GEM2034E-FIG7
Outline Drawing:	4002B5828PBP5471

Accessory Connection Diagrams

Bearing Thermocouple:	None	Heater:	None
RTD:	None	Thermistor:	None
Thermostat:	None	Winding Thermocouple:	None
Bearing RTD:	None		

Table of Contents

Specification	01
Performance Characteristics	02
Outline Drawing	03
Connection Drawing(s)	04
Spare parts	05

Marks:

MODEL NUMBER:	5KS286XAA181C	Estimated Weight:	510 Lbs
Outline Drawing:	4002B5828PBP5471	Time Rating:	CONT
Connection Diagram:	GEM2034E-FIG7	Enclosure:	TEFC
Instruction Book:	GEI-56128	Encl Construction:	841
Design Code:	28BD0153B	Ambient Max(°C):	40
Type:	KS	Alt Ambient Max(°C):	--
Frame:	286TSC	Insulation Class:	H
Phases:	3	NEMA Design:	B
Poles:	2	Nominal Efficiency:	92.4 %
Output Power:	30HP 22.2KW	Guaranteed Efficiency:	91.7 %
RPM:	3545	3/4 Load Efficiency:	93.4 %
Voltage:	575	KVA Code:	G
Hertz:	60	Max KVAR:	4.2
Amps - FL:	26.1	Power Factor:	93.0
Service Factor:	1.15	Bearing - DE:	6310ZC3
Alt Service Factor:	--	Bearing - ODE:	6310ZC3

Enclosure is Totally Enclosed Fan-Cooled

Stamped Nameplate Notes:

IEEE-STD-841-2009
 DE BRG 50BC03JP30 ODE BRG 50BC03JP30
 STAMP NP249A5564P051 AS BELOW:
 MODEL:5KS286XAA181C S/N: XXX
 CSA CERTIFIED CSA09.2216219 FOR EX NA IIC 200C GC
 CL 1 ZONE2 AEX NA IIC 200C;CL 1 DIV2 GRP ABCD 200C
 IN -25C <= AMB <= 40C, 1.0 SF ON SINE-WAVE PWR
 SURF TEMP 260C AT 1.15SF ON SINE-WAVE PWR
 OR 200C VT OR 215C CT OR 215C CHP PWM CONTROL
 ALTERNATE RATING FOR PWM CONTROL 1.0SF 40C AMB
 VT 0 - 60 HZ, CT 15-60HZ, CHP 60-90HZ.



Additional Information:

2P - TS EXTN
STANDARD FLOOR MOUNT
C/BOX 137 CU IN-1.50 NPT
F1 CONDUIT BOX MOUNTING
"C" FACE AT DE ENDSHIELD
PAINTED FRAME ID & SHAFT,
FAN COVER INSIDE & ODE E/S OUTSIDE
ROUTINE AND 5 POINT VIBRATION TESTS INCL IN C/BOX
INPRO SEAL BOTH ENDS
GROUND SCREW ON FRAME
ROTATE D.E. E/SHIELD 90 DEG. PER OUTLINE
SHAFT RUNOUT LIMIT .001" TIR
COPPER WASHER UNDER HEADS OF BEARING CAP BOLTS
APPLY TITE-SEAL (A50CD427A) ON BEARING CAP SCREWS, RABBETS,
AND PLUG THREADS
OIL RESISTANT SLEEVING ON LEADS



Performance Characteristics

1st Winding 1st Connection

Design: 28BD0153B

Marks:

LOAD %	125.0	115.0	100.0	75.0	50.0	25.0	0.0
% EFF	91.41	91.92	92.79	93.37	93.42	91.04	0.00
% PF	92.38	92.67	92.86	92.32	89.42	76.97	9.67
AMPS	33.25	30.32	26.07	19.54	13.44	8.01	4.72

TORQ(FL)#FT	44.4	TORQ(LR)%FL	283.23	TORQ(BD)%FL	272.48
AMPS(LR)	173.68	PF AT START	0.43		

This motor is capable of two cold or one hot start with a maximum connected load inertia of 111 Lb-Ft Sq (4.67 Kg-meter Sq)at 100% voltage, where the load torque varies with the square of the speed. Acceleration time with maximum inertia and the above load type is 18 seconds. Safe stall time at 100% voltage is 38 seconds cold, 21 seconds hot. Rotor inertia is 3.21 Lb-Ft Sq (0.14 Kg-meter Sq).

Open Circuit A-C:	1.035	Short Circuit D-C:	0.013
Short Circuit A-C:	0.025	X/R Ratio:	5.016
Stator Slots:	48	Rotor Slots:	38

Speed Torque Current Curve (First Connection, First Speed)

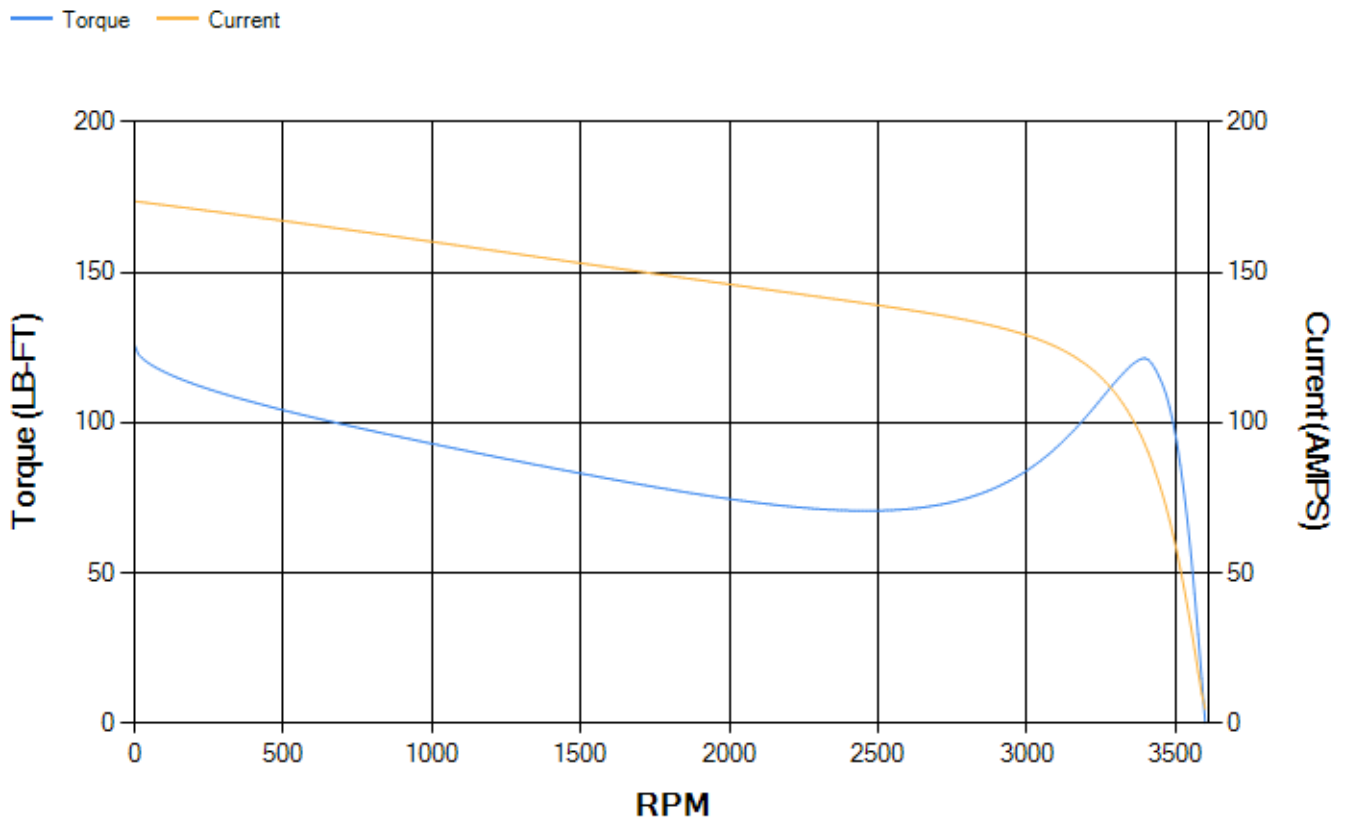

Marks:

- NOTE 1: CONDUIT BOX MAY BE ASSEMBLED WITH ENTRANCE UP, DOWN OR TO EITHER SIDE.
- NOTE 2: F1 ASSEMBLY AS SHOWN. F2 ASSEMBLY CONDUIT BOX ON OPPOSITE SIDE FROM SHOWN LOCATION.
- NOTE 3: MOUNTING SURFACES WILL BE SQUARE AND CONCENTRIC WITH SHAFT WITHIN .004 T. I. R.
- NOTE 4: SHAFT RUNOUT WILL NOT EXCEED .001 T. I. R.
- NOTE 5: DE ENDSHIELD ROTATED 90° COUNTER CLOCKWISE.
- NOTE 6: ALL DIMENSIONS ARE IN INCHES, BRACKETED DIMENSIONS ARE IN METRIC (MILLIMETERS)

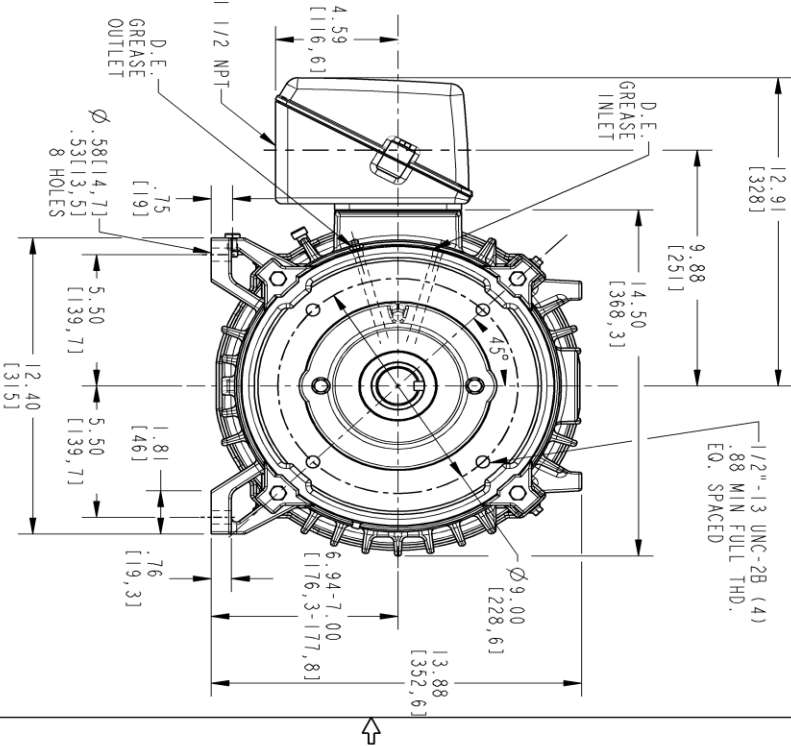
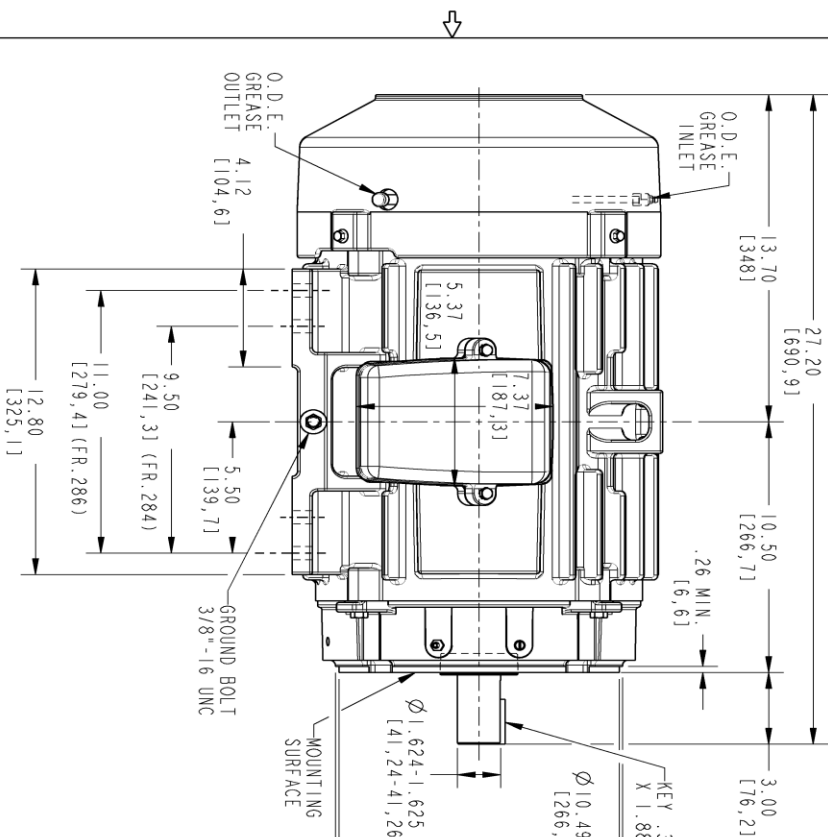

PROPRIETARY INFORMATION		REV. SHEET	
All rights reserved. This document and the information it contains is the property of the Molog Electric America LLC and/or its affiliates. It has been provided solely for transmission for design and engineering use and any of its reproduction or distribution is strictly prohibited except as expressly authorized in writing by the Molog Electric America LLC.		SIZE DRAWING NO. 4002B5828PBP5471 001	
REV.	DESCRIPTION	DATE	APPROVED
1	ISAC# 18-0869	11/12/18	PRASHANTH
REVISIONS			



SIGNATURES		DATE	
MODEL	LAKSHIKANTH	03/10/17	
DETAIL	LAKSHIKANTH	03/10/17	
CREATOR	PYUSH	03/10/17	
CHK	PYUSH	03/10/17	
QUALITY	LAKSHIKANTH	03/10/17	
ISSUED			
SOLID MODEL:	4002B5828PBP5471	SCALE:	0.225 REF. No.: 4002B5828PBP5313
TITLE		REV.	
INDUCTION MOTOR OUTLINE		B	
IEEE-941 SPECIFICATION (N507 RABERT)		4002B5828PBP5471 001	
FR. 284/286TSC TFC		SHEET 1 of 1	



Marks:

Connection Diagram
GEM2034E-FIG7



End shield Assembly		
Part Description	DE Side Part#	ODE Side Part#
End Shield	128D6206RF1	4004D5284SE1
Bearing	235A2508EC01	235A2508EC01
Slinger/Inproseal	4002B5914GF4	4002B5914AG5

Fan & Fan Cover Assembly	
Part Description	Part#
Fan	159C6704G02
Fan Cover	4003C5789PA1

Conduit & Accessories Box Assembly	
Part Description	Part#
Conduit Box	4002B5728PA-G01

Mechanical Accessories	
Part Description	Part#
Brake	
Tachometer	

