



GE INDUSTRIAL MOTORS
a **WOLONG** company

Product Technical Information

June 24, 2020

Data shown is for the current revision model #. Ensure your nameplate model # matches.

Model Number:	5KS284XAA114D3
Catalog Number:	M9575
Instruction Manual:	GEI-56128
Connection Diagram:	GEM2034E-FIG7
Outline Drawing:	4002B5828PAP5313

Accessory Connection Diagrams

Bearing Thermocouple:	None	Heater:	None
RTD:	None	Thermistor:	None
Thermostat:	None	Winding Thermocouple:	None
Bearing RTD:	None		

Table of Contents

Specification	01
Performance Characteristics	02
Outline Drawing	03
Connection Drawing(s)	04
Spare parts	05

Marks:

MODEL NUMBER:	5KS284XAA114D3	Estimated Weight:	460 Lbs
Outline Drawing:	4002B5828PAP5313	Time Rating:	CONT
Connection Diagram:	GEM2034E-FIG7	Enclosure:	TEFC
Instruction Book:	GEI-56128	Encl Construction:	841
Design Code:	28BD0159B	Ambient Max(°C):	40
Type:	KS	Alt Ambient Max(°C):	--
Frame:	284TS	Insulation Class:	H
Phases:	3	NEMA Design:	B
Poles:	2	Nominal Efficiency:	91.7 %
Output Power:	25HP 18.5KW	Guaranteed Efficiency:	91.0 %
RPM:	3550	3/4 Load Efficiency:	92.6 %
Voltage:	575	KVA Code:	G
Hertz:	60	Max KVAR:	4.8
Amps - FL:	22.4	Power Factor:	91.0
Service Factor:	1.15	Bearing - DE:	6310ZC3
Alt Service Factor:	--	Bearing - ODE:	6310ZC3

Enclosure is Totally Enclosed Fan-Cooled

Stamped Nameplate Notes:

IEEE-STD-841-2009
 DE BRG 50BC03JP30 ODE BRG 50BC03JP30
 STAMP NP249A5564P051 AS BELOW:
 MODEL:5KS284XAA114D3 S/N: XXX
 CSA CERTIFIED CSA09.2216219 FOR EX NA IIC 200 C GC
 CL1 ZONE2 AEX NA IIC 200 C; CL1 DIV2 GRP ABCD 200C
 IN -25C <= AMB <= 40C, 1.0 SF ON SINE-WAVE PWR
 SURF TEMP 260 C AT 1.15 SF ON SINE-WAVE PWR
 OR 200 C VT OR 215 C CT OR 215 C CHP PWM CONTROL
 ALTERNATE RATING FOR PWM CONTROL 1.0 SF 40 C AMB
 VT 0-60 HZ, CT 12-60 HZ, CHP 60-90 HZ.



Additional Information:

2P - TS EXTN
STANDARD FLOOR MOUNT
C/BOX 137 CU IN-1.50 NPT
F1 CONDUIT BOX MOUNTING
PAINTED FRAME ID & SHAFT,
FAN COVER INSIDE & ODE E/S OUTSIDE
ROUTINE AND 5 POINT VIBRATION TESTS INCL IN C/BOX
INPRO SEAL BOTH ENDS
GROUND SCREW ON FRAME
SHAFT RUNOUT LIMIT .001" TIR
COPPER WASHER UNDER HEADS OF BEARING CAP BOLTS
APPLY TITE-SEAL (A50CD427A) ON BEARING CAP SCREWS, RABBETS,
AND PLUG THREADS
OIL RESISTANT SLEEVING ON LEADS



Performance Characteristics

1st Winding 1st Connection

Design: 28BD0159B

Marks:

LOAD %	125.0	115.0	100.0	75.0	50.0	25.0	0.0
% EFF	90.61	91.14	92.02	92.55	92.42	89.4	0.00
% PF	90.84	90.97	90.86	89.44	84.6	67.84	8.65
AMPS	28.42	25.96	22.39	16.96	11.97	7.72	5.38

TORQ(FL)#FT	36.99	TORQ(LR)%FL	228.14	TORQ(BD)%FL	270.35
AMPS(LR)	139.8	PF AT START	0.39		

This motor is capable of two cold or one hot start with a maximum connected load inertia of 80 Lb-Ft Sq (3.37 Kg-meter Sq)at 100% voltage, where the load torque varies with the square of the speed. Acceleration time with maximum inertia and the above load type is 18 seconds. Safe stall time at 100% voltage is 39 seconds cold, 22 seconds hot. Rotor inertia is 2.11 Lb-Ft Sq (0.09 Kg-meter Sq).

Open Circuit A-C:	0.79	Short Circuit D-C:	0.013
Short Circuit A-C:	0.027	X/R Ratio:	4.784
Stator Slots:	48	Rotor Slots:	38

Speed Torque Current Curve (First Connection, First Speed)

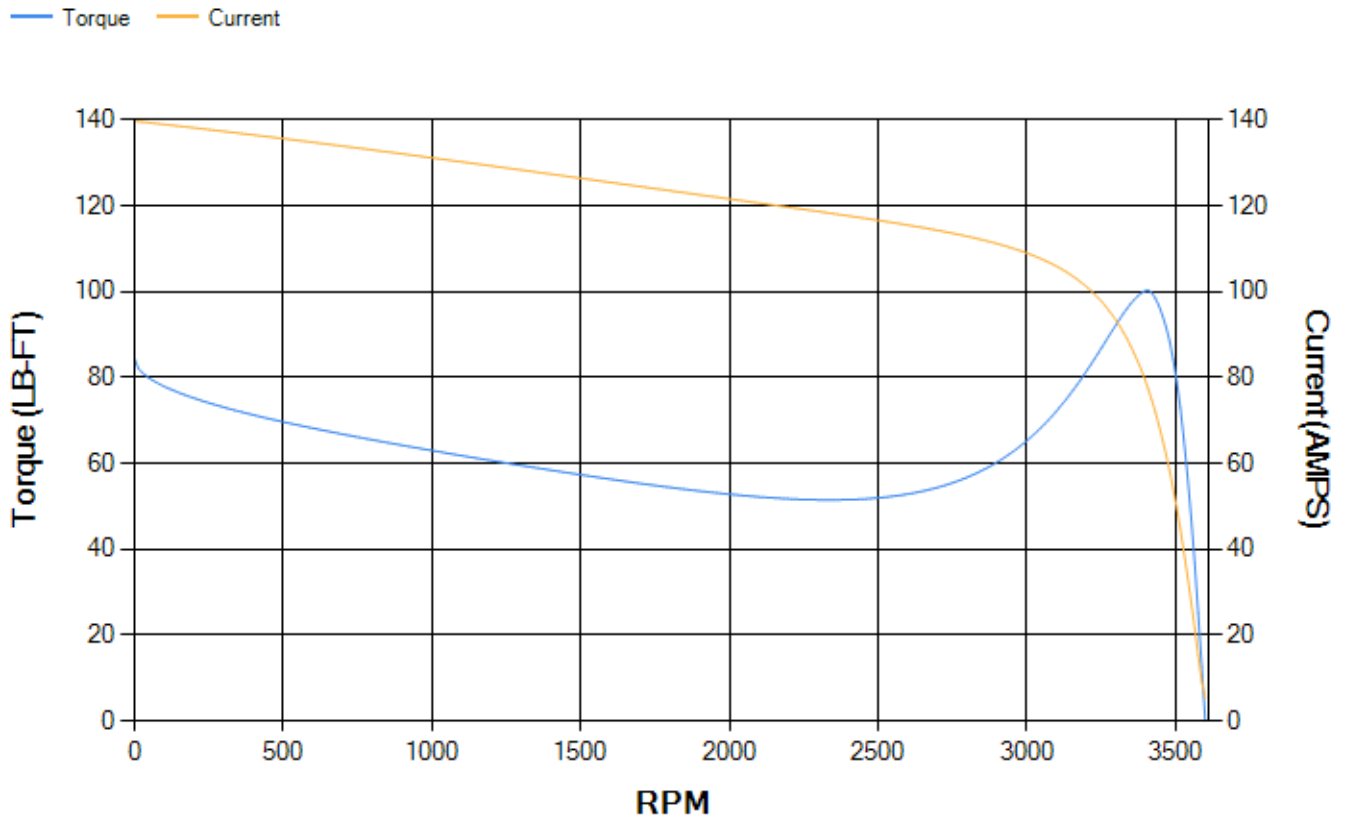

Marks:

NOTE 1: CONDUIT BOX MAY BE ASSEMBLED WITH ENTRANCE UP, DOWN OR TO EITHER SIDE.
 NOTE 2: F1 ASSEMBLY AS SHOWN, F2 ASSEMBLY CONDUIT BOX ON OPPOSITE SIDE FROM SHOWN LOCATION.
 NOTE 3: SHAFT RUNOUT WILL NOT EXCEED .001 T.I.R.
 NOTE 4: ALL DIMENSIONS ARE IN INCHES & BRACKETED DIMENSIONS ARE IN METRIC (MILLIMETERS)

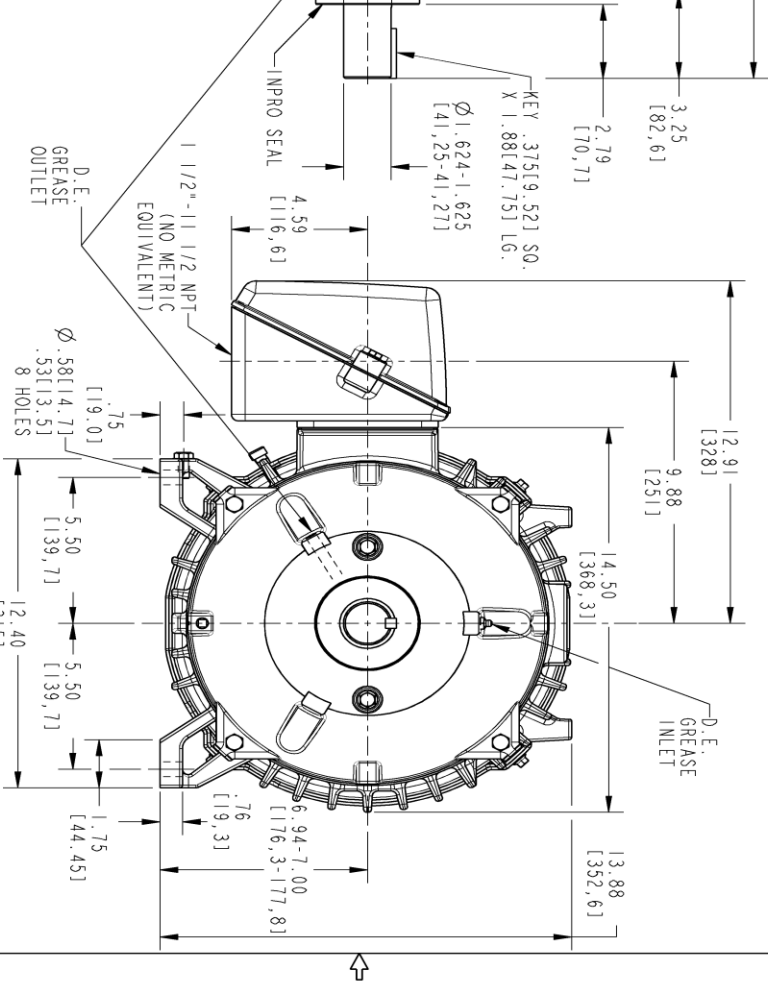
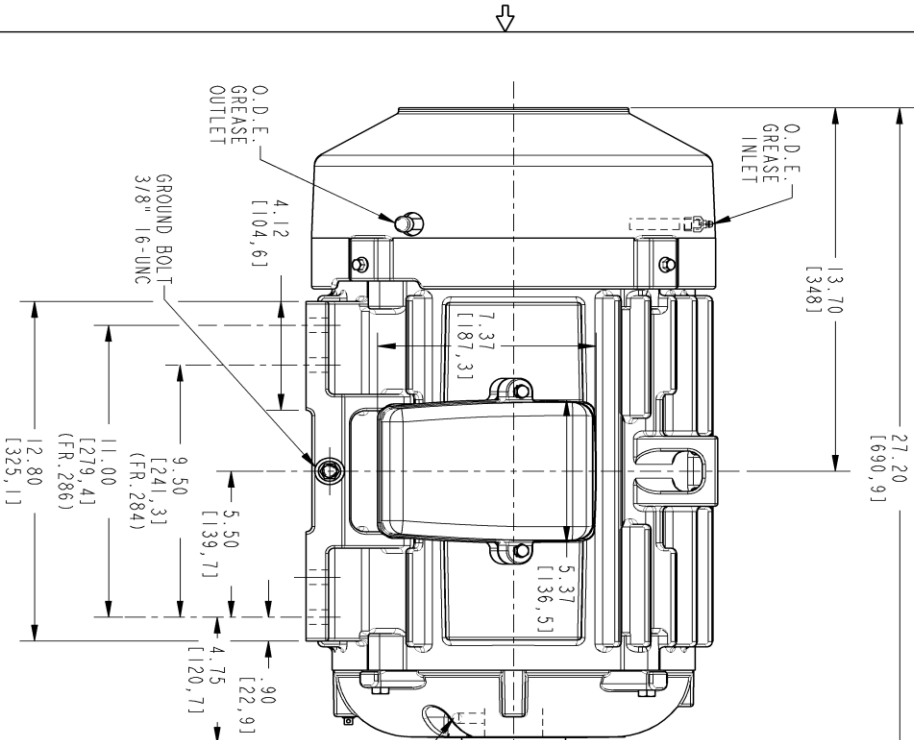

PROPRIETARY INFORMATION
 © COPYRIGHT 2018 Wolog Electric America LLC AND/OR ITS AFFILIATES
 All rights reserved. This document and the information it contains is the property of Wolog Electric America LLC and/or its affiliates. It has been provided solely for transmission to the recipient for their use only. No other use, reproduction, or distribution is strictly prohibited except as expressly authorized in writing by Wolog Electric America LLC.

REV.	DESCRIPTION	DATE	APPROVED
1	ISAC# 16-0298	04/04/2016	MARAYANA
2	ISAC# 18-0869	01/31/19	PRAASHANTH

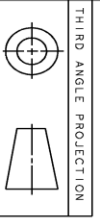

SIGNATURES	DATE
TEJASNI	06/29/15
TEJASNI	06/29/15
ADINARAYANA	06/29/15
ANIL	06/29/15

GE INDUSTRIAL MOTORS
 a Wolog company

TITLE
INDUCTION MOTOR OUTLINE

284/286 TS, TFC, IEEE-941

CBOX 137 CUL - 150 NPT, INPRO SEAL, GROUND PAD

SCALE: 0.250 REF. NO.: 4002B5828PAP5302

4002B5828PAP5313

REV: 002

SHEET 1 OF 1

Marks:

Connection Diagram
GEM2034E-FIG7



End shield Assembly		
Part Description	DE Side Part#	ODE Side Part#
End Shield	4004D5284PB1	4004D5284SE1
Bearing	235A2508EC01	235A2508EC01
Slinger/Inproseal	4002B5914AF6	4002B5914AG5

Fan & Fan Cover Assembly	
Part Description	Part#
Fan	159C6704G02
Fan Cover	4003C5789PA1

Conduit & Accessories Box Assembly	
Part Description	Part#
Conduit Box	4002B5728PA-G01

Mechanical Accessories	
Part Description	Part#
Brake	
Tachometer	

