



**GE INDUSTRIAL MOTORS**  
a **WOLONG** company

# Product Technical Information

June 25, 2020

Data shown is for the current revision model #. Ensure your nameplate model # matches.

<b>Model Number:</b>	<b>5KS365XAA304D5</b>
<b>Catalog Number:</b>	<b>M9589</b>
<b>Instruction Manual:</b>	GEI-56128
<b>Connection Diagram:</b>	GEM2034E-FIG1
<b>Outline Drawing:</b>	239C6200RC

## Accessory Connection Diagrams

<b>Bearing Thermocouple:</b>	None	<b>Heater:</b>	None
<b>RTD:</b>	None	<b>Thermistor:</b>	None
<b>Thermostat:</b>	None	<b>Winding Thermocouple:</b>	None
<b>Bearing RTD:</b>	None		

## Table of Contents

Specification	01
Performance Characteristics	02
Outline Drawing	03
Connection Drawing(s)	04
Spare parts	05

Marks:

<b>MODEL NUMBER:</b>	<b>5KS365XAA304D5</b>	<b>Estimated Weight:</b>	1000 Lbs
<b>Outline Drawing:</b>	239C6200RC	<b>Time Rating:</b>	CONT
<b>Connection Diagram:</b>	GEM2034E-FIG1	<b>Enclosure:</b>	TEFC
<b>Instruction Book:</b>	GEI-56128	<b>Encl Construction:</b>	841
<b>Design Code:</b>	36BD3090B	<b>Ambient Max(°C):</b>	40
<b>Type:</b>	KS	<b>Alt Ambient Max(°C):</b>	--
<b>Frame:</b>	365T	<b>Insulation Class:</b>	H
<b>Phases:</b>	3	<b>NEMA Design:</b>	B
<b>Poles:</b>	6	<b>Nominal Efficiency:</b>	94.1 %
<b>Output Power:</b>	50HP 37KW	<b>Guaranteed Efficiency:</b>	93.6 %
<b>RPM:</b>	1185	<b>3/4 Load Efficiency:</b>	94.2 %
<b>Voltage:</b>	575	<b>KVA Code:</b>	G
<b>Hertz:</b>	60	<b>Max KVAR:</b>	20.4
<b>Amps - FL:</b>	49.4	<b>Power Factor:</b>	80.5
<b>Service Factor:</b>	1.15	<b>Bearing - DE:</b>	6314ZC3
<b>Alt Service Factor:</b>	--	<b>Bearing - ODE:</b>	6314ZC3

Enclosure is Totally Enclosed Fan-Cooled

---

Stamped Nameplate Notes:

IEEE-STD-841-2009

DE BRG 70BC03JP30, ODE BRG 70BC03JP30

STAMP NP249A5564P051 AS BELOW:

MODEL:5KS365XAA304D5 S/N: XXX

CSA CERTIFIED CSA09.2216219 FOR EX NA IIC 200 C GC

CL 1 ZONE2 AEX NA IIC 200C;CL 1 DIV2 GRP ABCD 200C

IN -25C <= AMB <= 40C, 1.0 SF ON SINE-WAVE PWR

SURF TEMP 230C AT 1.15SF ON SINE-WAVE PWR

OR 200C VT OR 230C CT OR 200C CHP PWM CONTROL

ALTERNATE RATING FOR PWM CONTROL 1.0SF 40C AMB

VT 0-60 HZ, CT 10-60 HZ, CHP 60-90 HZ.



**Additional Information:**

6P - T EXTN  
PAINTED FRAME ID & SHAFT,  
FAN COVER INSIDE & ODE E/S OUTSIDE  
346 CU IN - 3.00" NPT  
INPRO SEAL BOTH ENDS  
OIL RESISTANT SLEEVING ON LEADS  
.0015" TIR SHAFT RUNOUT  
ROUTINE TEST REPORT AND 5 POINT VIBRATION TEST  
REPORT INCLUDED IN C/B  
COPPER WASHER UNDER HEADS OF BEARING CAP BOLTS,  
APPLY TITE-SEAL (A50CD427A) ON BEARING CAP SCREWS,  
RABBETS AND PLUG THREADS.  
GROUND PAD  
F1 MOUNTING



**Performance Characteristics**

1st Winding 1st Connection

**Design: 36BD3090B**

**Marks:**

LOAD %	125.0	115.0	100.0	75.0	50.0	25.0	0.0
% EFF	93.24	93.53	94.1	94.24	93.87	91.01	0.00
% PF	83.17	82.25	80.25	74.4	62.76	40.09	3.2
AMPS	60.34	55.96	49.46	40.05	31.77	25.66	22.82

<b>TORQ(FL)#FT</b>	221.33	<b>TORQ(LR)%FL</b>	172.74	<b>TORQ(BD)%FL</b>	281.14
<b>AMPS(LR)</b>	293.76	<b>PF AT START</b>	0.38		

This motor is capable of two cold or one hot start with a maximum connected load inertia of 2962 Lb-Ft Sq (124.7 Kg-meter Sq) at 100% voltage, where the load torque varies with the square of the speed. Acceleration time with maximum inertia and the above load type is 38 seconds. Safe stall time at 100% voltage is 92 seconds cold, 49 seconds hot. Rotor inertia is 20.06 Lb-Ft Sq (0.84 Kg-meter Sq).

<b>Open Circuit A-C:</b>	0.456	<b>Short Circuit D-C:</b>	0.015
<b>Short Circuit A-C:</b>	0.027	<b>X/R Ratio:</b>	5.707
<b>Stator Slots:</b>	72	<b>Rotor Slots:</b>	58

**Speed Torque Current Curve (First Connection, First Speed)**

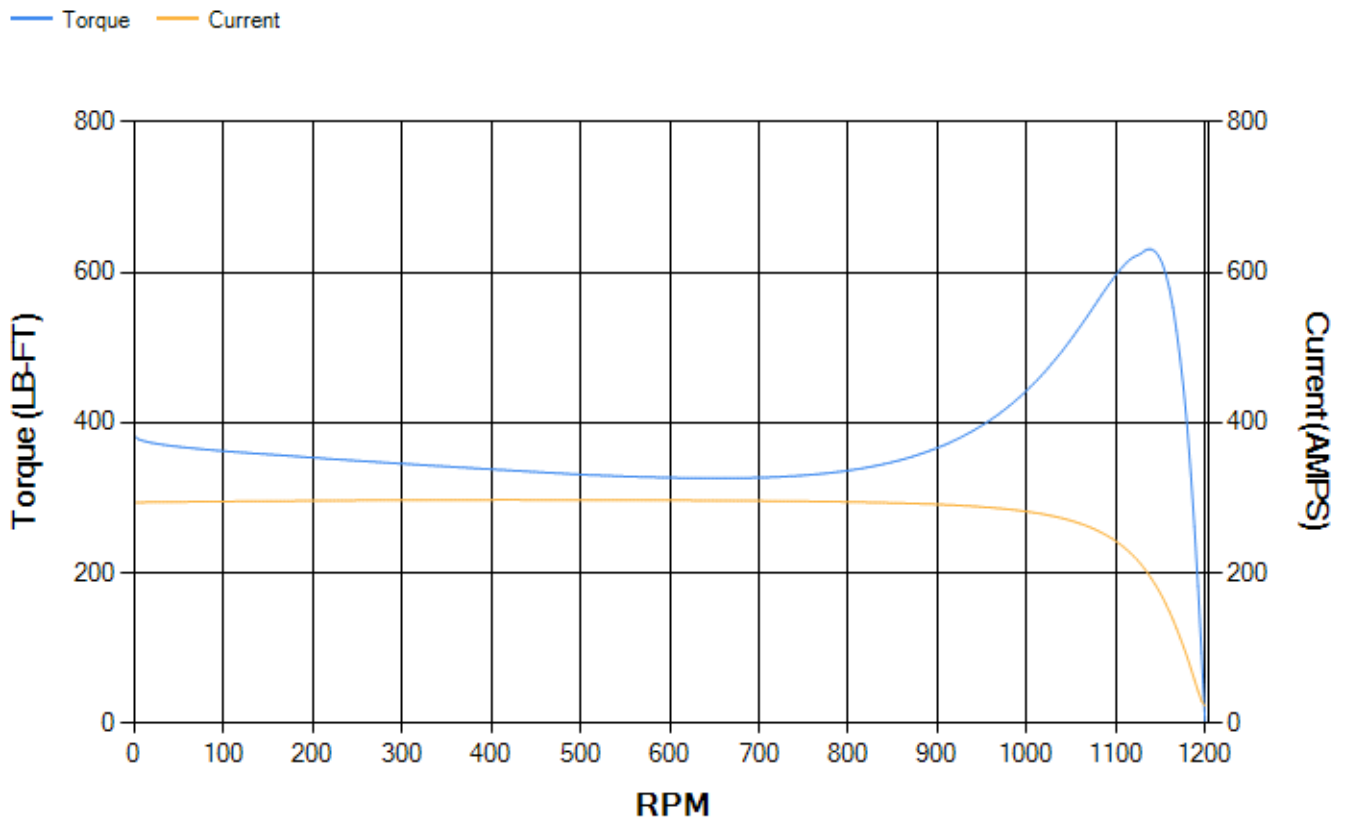

Marks:

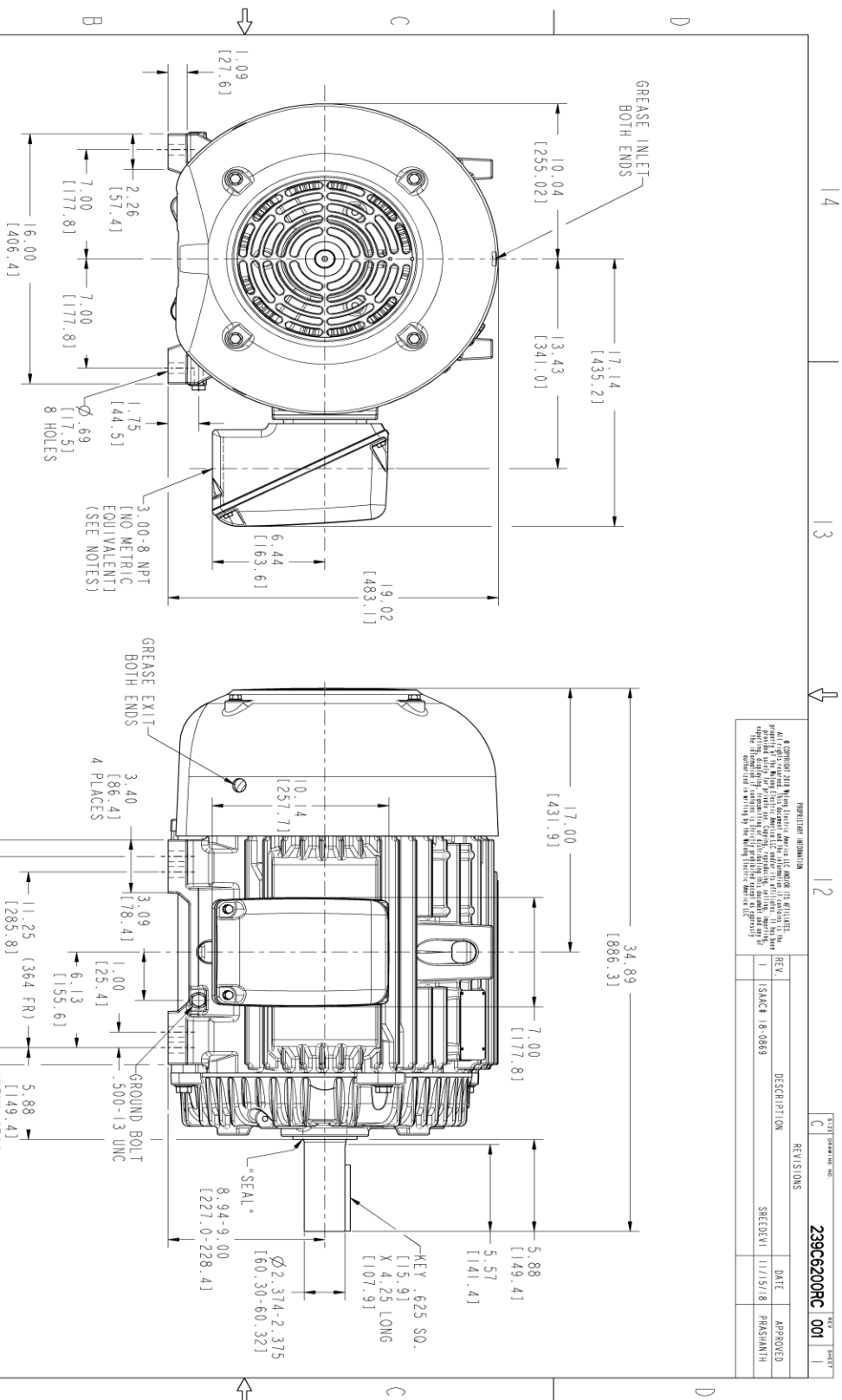

- NOTES :
1. CONDUIT BOX MAY BE PLACED WITH THE ENTRANCE DOWN, UP OR ON EITHER SIDE.
  2. F-1 ASM AS SHOWN.
  3. F-2 ASM HAS CONDUIT BOX ON OPPOSITE SIDE.
  4. BRACKETED DIMENSIONS ARE METRIC (MILLIMETERS).
  5. TOLERANCE ON PERMISSIBLE SHAFT EXTENSION RUNOUT IS .0015 T.I.R.

REVISIONS		DATE	APPROVED
REV.	DESCRIPTION	DATE	APPROVED
1	ISACH 18-0869	11/15/18	PRASHANTH

SIGNATURES		DATE	<p><b>GE INDUSTRIAL MOTORS</b> a WOLONG company</p> <p><b>OUTLINE</b></p> <p><b>364/365 T TEFC XSD 841</b></p> <p><b>346 CU IN CONDUIT BOX</b></p> <p><b>239C6200RC</b></p>
MODEL	TEJSMI	06/19/15	
REVISED	TEJSMI	06/19/15	
CHECKED	TEJSMI	06/19/15	
DESIGNED	TEJSMI	06/19/15	SCALE: 0.240 REF. NO: 239C620046 SHEET 1 OF 1
ISSUED	TEJSMI	06/19/15	



**Marks:**

**Connection Diagram**  
**GEM2034E-FIG1**

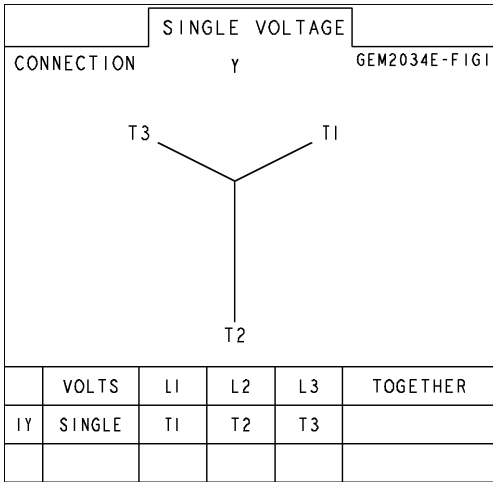

End shield Assembly		
Part Description	DE Side Part#	ODE Side Part#
End Shield	115E4250AA1	115E4250LK1
Bearing	235A2516AC01	235A2516AC01
Slinger/Inproseal	235A4575GS3	235A4575GS3

Fan & Fan Cover Assembly	
Part Description	Part#
Fan	159C7100G01
Fan Cover	128D6810AA1

Conduit & Accessories Box Assembly	
Part Description	Part#
Conduit Box	149C4429AA2

Mechanical Accessories	
Part Description	Part#
Brake	
Tachometer	

