



GE INDUSTRIAL MOTORS
a **WOLONG** company

Product Technical Information

April 11, 2021

Data shown is for the current revision model #. Ensure your nameplate model # matches.

Model Number:	5KS286SAA405D4
Catalog Number:	M9885
Instruction Manual:	GEI-56128
Connection Diagram:	GEM2034E-FIG9
Outline Drawing:	4002B5828PAP5943

Accessory Connection Diagrams

Bearing Thermocouple:	None	Heater:	None
RTD:	None	Thermistor:	None
Thermostat:	None	Winding Thermocouple:	None
Bearing RTD:	None		

Table of Contents

Specification	01
Performance Characteristics	02
Outline Drawing	03
Connection Drawing(s)	04
Spare parts	05

Marks:

MODEL NUMBER:	5KS286SAA405D4	Estimated Weight:	510 Lbs
Outline Drawing:	4002B5828PAP5943	Time Rating:	CONT
Connection Diagram:	GEM2034E-FIG9	Enclosure:	TEFC
Instruction Book:	GEI-56128	Encl Construction:	841
Design Code:	28BD4035A	Ambient Max(°C):	40
Type:	KS	Alt Ambient Max(°C):	--
Frame:	286T	Insulation Class:	H
Phases:	3	NEMA Design:	A
Poles:	8	Nominal Efficiency:	89.5 %
Output Power:	15HP 11.1KW	Guaranteed Efficiency:	88.5 %
RPM:	885	3/4 Load Efficiency:	--
Voltage:	230/460	KVA Code:	J
Hertz:	60	Max KVAR:	7.1
Amps - FL:	41.6/20.8	Power Factor:	75.5
Service Factor:	1.15	Bearing - DE:	6310ZC3
Alt Service Factor:	--	Bearing - ODE:	6310ZC3

Enclosure is Totally Enclosed Fan-Cooled

Stamped Nameplate Notes:

DE BRG 50BC03JP30 ODE BRG 50BC03JP30
 EXCEPTION TO IEEE-STD-841-2009: DUAL VOLTAGE
 STAMP NP249A5564P051 AS BELOW:
 MODEL:5KS286SAA405D4 S/N: XXX
 CSA CERTIFIED CSA09.2216219 FOR EX NA IIC 200C GC
 CL 1 ZONE2 AEX NA IIC 200C;CL 1 DIV2 GRP ABCD 200C
 IN -40C <= AMB <= 40C, 1.0 SF ON SINE-WAVE PWR
 SURF TEMP 200C AT 1.15SF ON SINE-WAVE PWR
 OR 200C VT OR 215C CT OR 200C CHP PWM CONTROL
 ALTERNATE RATING FOR PWM CONTROL 1.0SF 40C AMB
 VT 0 - 60 HZ, CT 6-60 HZ, CHP 60-90 HZ.



Additional Information:

8P - T EXTN
STANDARD FLOOR MOUNT
C/BOX 137 CU IN-1.50 NPT
F1 CONDUIT BOX MOUNTING
PAINTED FRAME ID & SHAFT,
FAN COVER INSIDE & ODE E/S OUTSIDE
ROUTINE AND 5 POINT VIBRATION TESTS INCL IN C/BOX
GROUND SCREW ON FRAME
SHAFT RUNOUT LIMIT .0015" TIR
OIL RESISTANT SLEEVING ON LEADS



Performance Characteristics

1st Winding 1st Connection

Design: 28BD4035A

Marks:

LOAD %	125.0	115.0	100.0	75.0	50.0	25.0	0.0
% EFF	87.51	88.32	89.54	90.5	90.57	87.2	0.00
% PF	78.21	77.35	75.34	69.24	57.5	36.29	4.01
AMPS	25.64	23.63	20.79	16.8	13.48	11.09	9.95

TORQ(FL)#FT	89.14	TORQ(LR)%FL	218.65	TORQ(BD)%FL	343.14
AMPS(LR)	142.68	PF AT START	0.36		

This motor is capable of two cold or one hot start with a maximum connected load inertia of 1047 Lb-Ft Sq (44.08 Kg-meter Sq)at 100% voltage, where the load torque varies with the square of the speed. Acceleration time with maximum inertia and the above load type is 25 seconds. Safe stall time at 100% voltage is 65 seconds cold, 37 seconds hot. Rotor inertia is 7.36 Lb-Ft Sq (0.31 Kg-meter Sq).

Open Circuit A-C:	0.292	Short Circuit D-C:	0.009
Short Circuit A-C:	0.02	X/R Ratio:	3.558
Stator Slots:	54	Rotor Slots:	70

Speed Torque Current Curve (First Connection, First Speed)

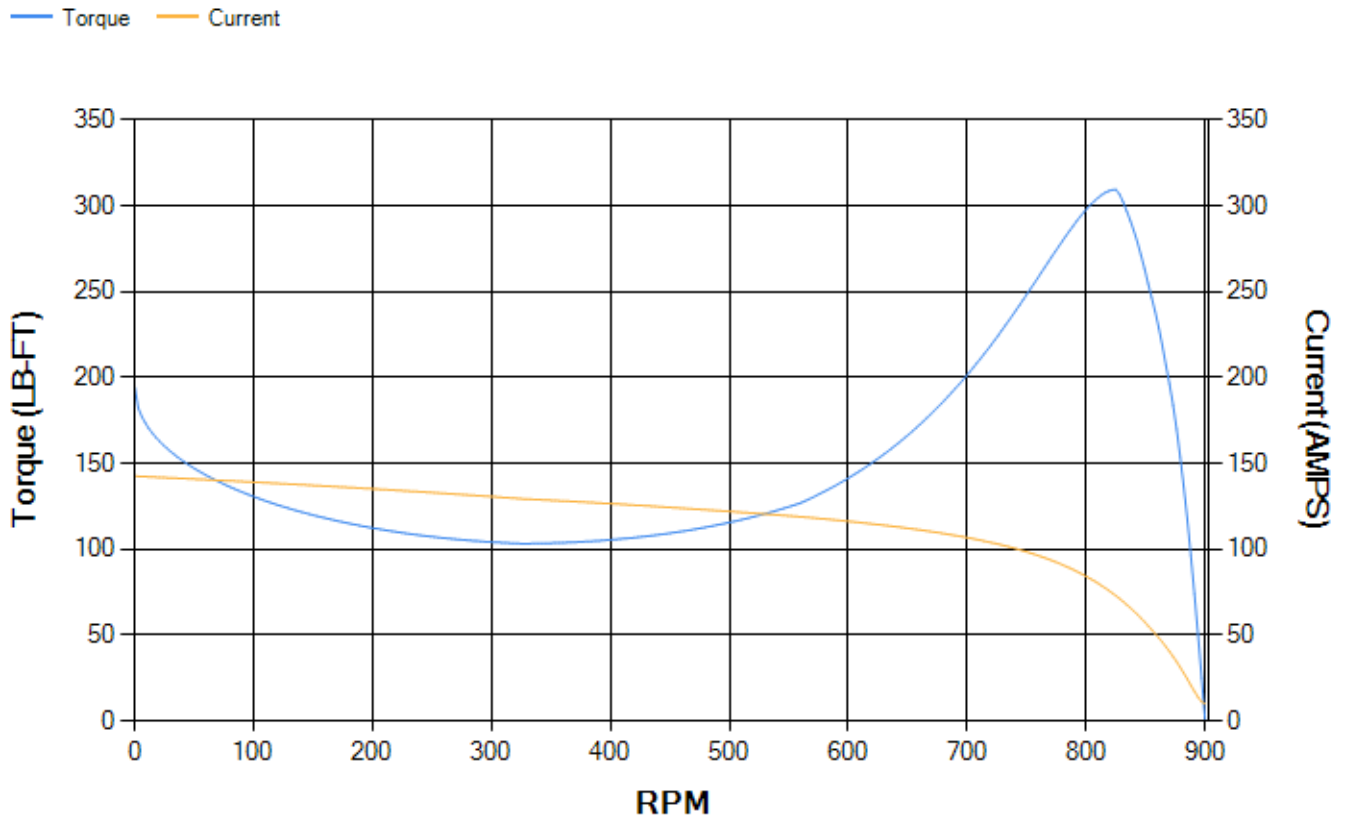

Marks:

NOTE 1: CONDUIT BOX MAY BE ASSEMBLED WITH ENTRANCE UP, DOWN OR TO EITHER SIDE.
 NOTE 2: FIT ASSEMBLY AS SHOWN.
 NOTE 3: ALL DIMENSIONS ARE IN INCHES, BRACKETED DIMENSIONS ARE IN METRIC (MILLIMETERS).

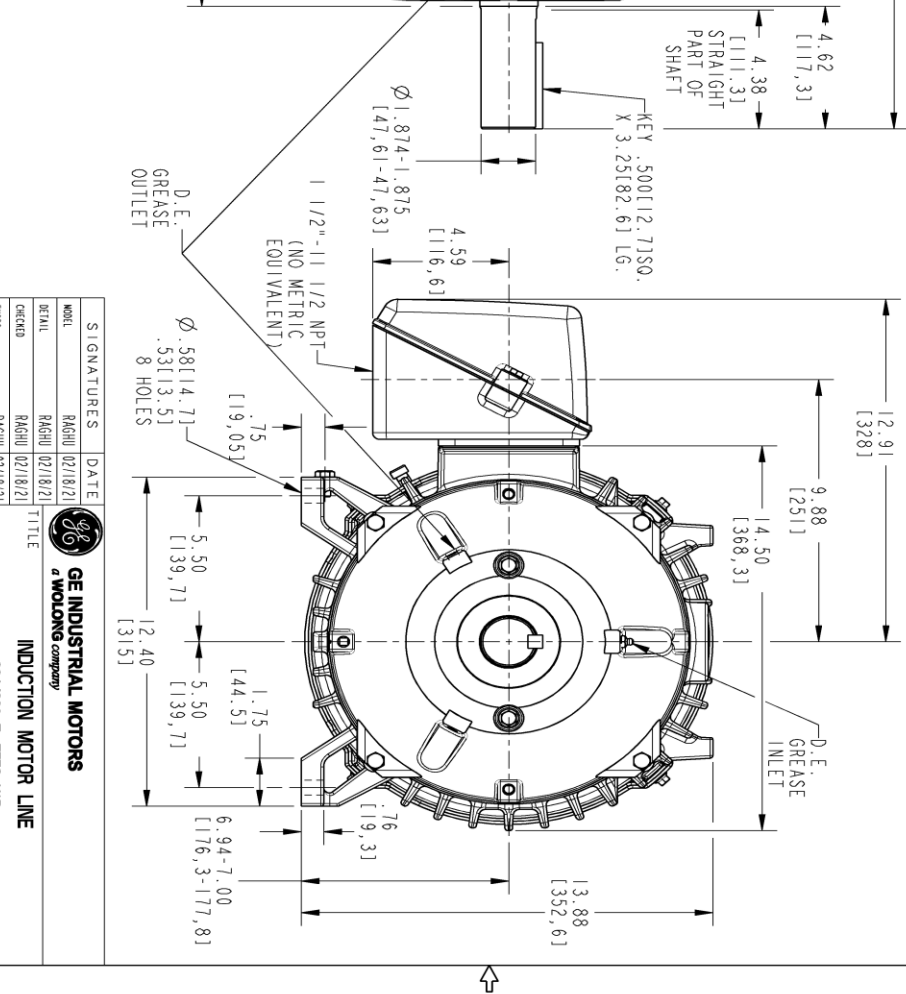
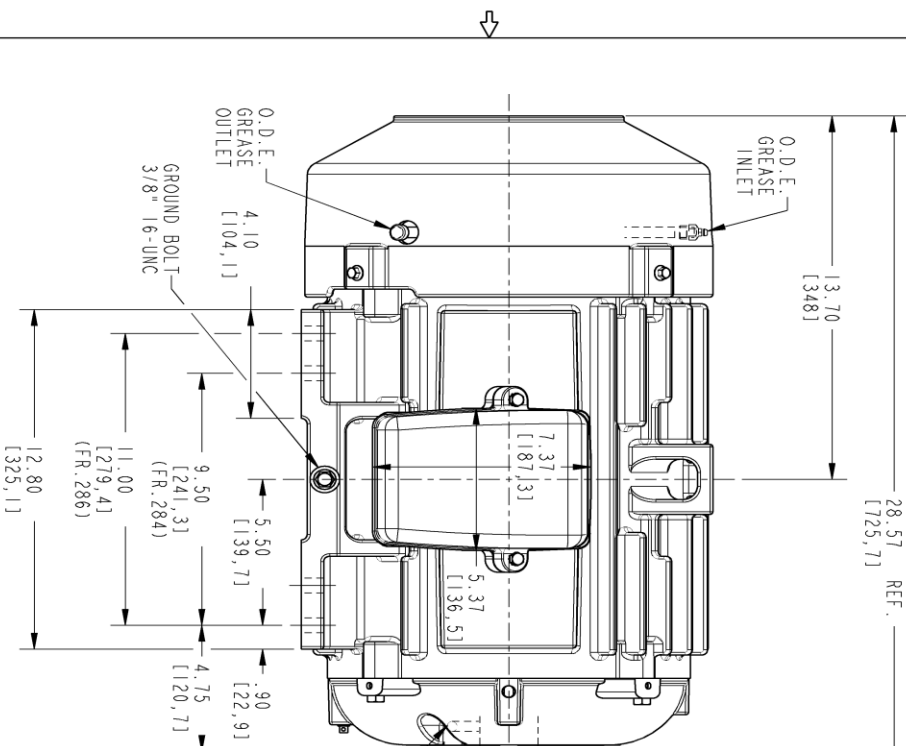

PROPRIETARY INFORMATION
 © COPYRIGHT 2018 Wolog Electric America LLC AND/OR ITS AFFILIATES
 All rights reserved. This document and the information it contains is the property of the Wolog Electric America LLC and/or its affiliates. It has been provided solely for transmission and use of the equipment shown and any other use, reproduction, or distribution is strictly prohibited except as expressly authorized in writing by the Wolog Electric America LLC.

REV.	DESCRIPTION	DATE	APPROVED

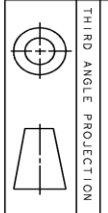

SIGNATURES	DATE
MODEL	02/18/21
DETAIL	02/18/21
CHECKED	02/18/21
ENGR	02/18/21
QC	
ISSUED	02/18/21
SOLID MODEL:	4002B5828PAP5943

GE INDUSTRIAL MOTORS
 a Wolog company
INDUCTION MOTOR LINE
 284/286 T, TEFC XSD
 C/BOX 137 CUIN GROUND PAD
4002B5828PAP5943
 SCALE: 0.250 REF. No.: 4002B5828PAP5311

REV	DESCRIPTION
000	

SHEET DRAWING
 4002B5828PAP5943
 SHEET 1 OF 1

Marks:

Connection Diagram
GEM2034E-FIG9



End shield Assembly		
Part Description	DE Side Part#	ODE Side Part#
End Shield	4004D5284PB1	4004D5284SE1
Bearing	235A2508EC01	235A2508EC01
Slinger/Inproseal	149C4399G03	149C4399G03

Fan & Fan Cover Assembly	
Part Description	Part#
Fan	159C6900G01
Fan Cover	4003C5789PA1

Conduit & Accessories Box Assembly	
Part Description	Part#
Conduit Box	4002B5728PA-G01

Mechanical Accessories	
Part Description	Part#
Brake	
Tachometer	

