



**GE INDUSTRIAL MOTORS**  
a **WOLONG** company

# Product Technical Information

March 7, 2021

Data shown is for the current revision model #. Ensure your nameplate model # matches.

<b>Model Number:</b>	<b>5KS215SAA200D1</b>
<b>Catalog Number:</b>	<b>M9892</b>
<b>Instruction Manual:</b>	GEI-56128
<b>Connection Diagram:</b>	GEM2034E-FIG7
<b>Outline Drawing:</b>	4002B5821PBP5820

## Accessory Connection Diagrams

<b>Bearing Thermocouple:</b>	None	<b>Heater:</b>	None
<b>RTD:</b>	None	<b>Thermistor:</b>	None
<b>Thermostat:</b>	None	<b>Winding Thermocouple:</b>	None
<b>Bearing RTD:</b>	None		

## Table of Contents

Specification	01
Performance Characteristics	02
Outline Drawing	03
Connection Drawing(s)	04
Spare parts	05

Marks:

<b>MODEL NUMBER:</b>	<b>5KS215SAA200D1</b>	<b>Estimated Weight:</b>	220 Lbs
<b>Outline Drawing:</b>	4002B5821PBP5820	<b>Time Rating:</b>	CONT
<b>Connection Diagram:</b>	GEM2034E-FIG7	<b>Enclosure:</b>	TEFC
<b>Instruction Book:</b>	GEI-56128	<b>Encl Construction:</b>	841
<b>Design Code:</b>	21BD1285A	<b>Ambient Max(°C):</b>	40
<b>Type:</b>	KS	<b>Alt Ambient Max(°C):</b>	--
<b>Frame:</b>	215TC	<b>Insulation Class:</b>	H
<b>Phases:</b>	3	<b>NEMA Design:</b>	B
<b>Poles:</b>	4	<b>Nominal Efficiency:</b>	91.7 %
<b>Output Power:</b>	10HP 7.4KW	<b>Guaranteed Efficiency:</b>	91.0 %
<b>RPM:</b>	1770	<b>3/4 Load Efficiency:</b>	--
<b>Voltage:</b>	460	<b>KVA Code:</b>	H
<b>Hertz:</b>	60	<b>Max KVAR:</b>	3.2
<b>Amps - FL:</b>	12.3	<b>Power Factor:</b>	83.0
<b>Service Factor:</b>	1.15	<b>Bearing - DE:</b>	6309ZC3
<b>Alt Service Factor:</b>	--	<b>Bearing - ODE:</b>	6208ZC3

Enclosure is Totally Enclosed Fan-Cooled

---

Stamped Nameplate Notes:

IEEE-STD-841-2009

DE BRG 45BC03JP30 ODE BRG 40BC02JP30

STAMP NP249A5564P051 AS BELOW:

MODEL:5KS215SAA200D1 S/N: XXX

CSA CERTIFIED CSA09.2216219 FOR EX NA IIC 200C GC

CL 1 ZONE2 AEX NA IIC 200C;CL 1 DIV2 GRP ABCD 200C

IN -40C <= AMB <= 40C, 1.0 SF ON SINE-WAVE PWR

SURF TEMP 200C AT 1.15SF ON SINE-WAVE PWR

OR 200C VT OR 215C CT OR 200C CHP PWM CONTROL

ALTERNATE RATING FOR PWM CONTROL 1.0SF 40C AMB

VT 0 - 60 HZ, CT 3-60 HZ, CHP 60-90 HZ.



**Additional Information:**

4P - T EXTN  
STANDARD FLOOR MOUNT  
C/BOX 55 CU IN-1.00 NPT  
F1 CONDUIT BOX MOUNTING  
"C" FACE AT DE ENDSHIELD  
PAINTED FRAME ID & SHAFT,  
FAN COVER INSIDE & ODE E/S OUTSIDE  
ROUTINE AND 5 POINT VIBRATION TESTS INCL IN C/BOX  
GROUND SCREW ON FRAME  
ROTATE D.E. E/SHIELD 90 DEG. PER OUTLINE  
SHAFT RUNOUT LIMIT .001" TIR  
OIL RESISTANT SLEEVING ON LEADS



**Performance Characteristics**

1st Winding 1st Connection

**Design: 21BD1285A**

**Marks:**

LOAD %	125.0	115.0	100.0	75.0	50.0	25.0	0.0
% EFF	90.74	91.25	92.08	92.5	92.18	88.76	0.00
% PF	84.09	83.91	83.1	79.6	70.87	49.62	5.71
AMPS	15.33	14.06	12.23	9.53	7.16	5.31	4.41

<b>TORQ(FL)#FT</b>	29.69	<b>TORQ(LR)%FL</b>	201.19	<b>TORQ(BD)%FL</b>	286.82
<b>AMPS(LR)</b>	82.68	<b>PF AT START</b>	0.4		

This motor is capable of two cold or one hot start with a maximum connected load inertia of 370 Lb-Ft Sq (15.58 Kg-meter Sq)at 100% voltage, where the load torque varies with the square of the speed. Acceleration time with maximum inertia and the above load type is 47 seconds. Safe stall time at 100% voltage is 105 seconds cold, 71 seconds hot. Rotor inertia is 1.12 Lb-Ft Sq (0.05 Kg-meter Sq).

<b>Open Circuit A-C:</b>	0.418	<b>Short Circuit D-C:</b>	0.013
<b>Short Circuit A-C:</b>	0.02	<b>X/R Ratio:</b>	5.049
<b>Stator Slots:</b>	36	<b>Rotor Slots:</b>	28

**Speed Torque Current Curve (First Connection, First Speed)**

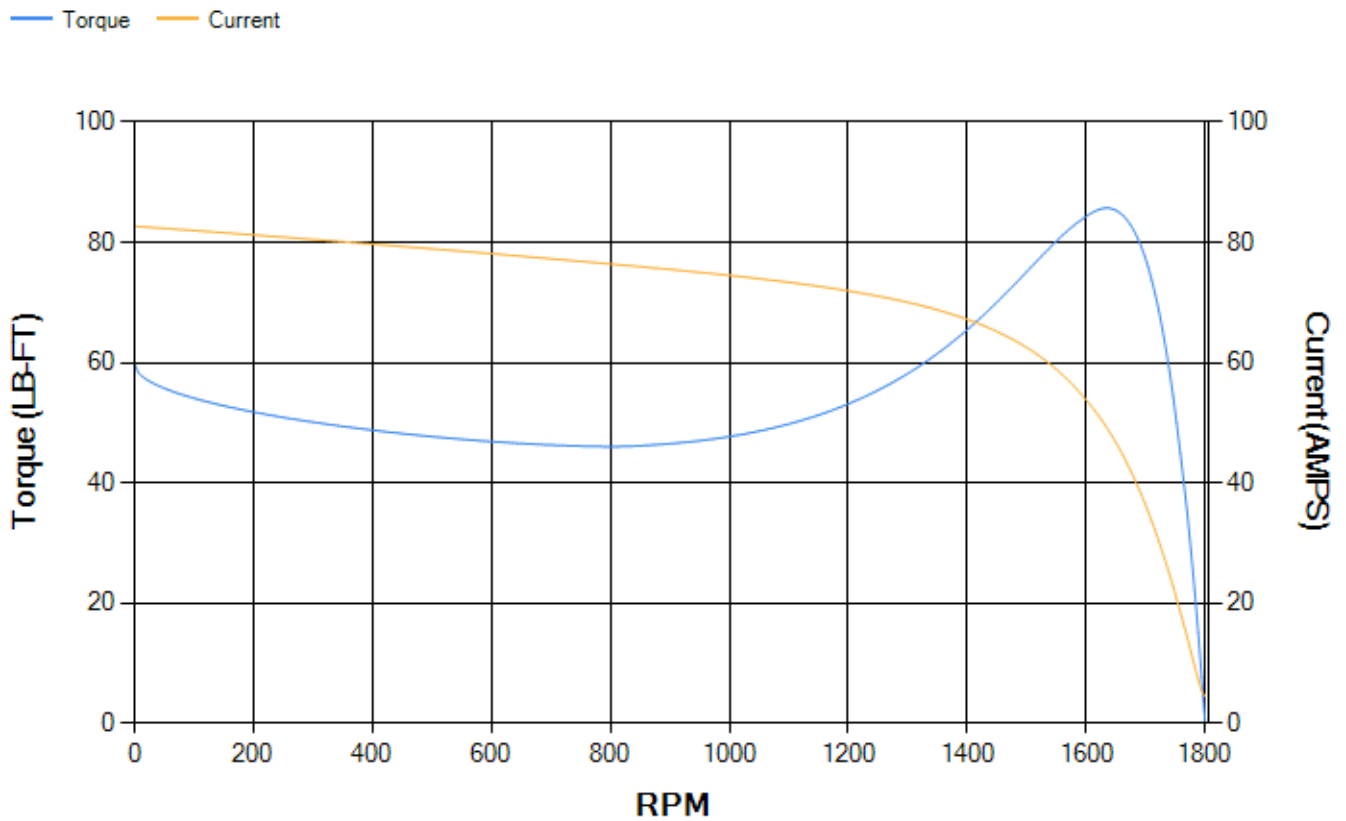

Marks:

NOTE 1: CONDUIT BOX MAY BE ASSEMBLED WITH ENTRANCE UP, DOWN OR TO EITHER SIDE.  
 NOTE 2: F1 ASSEMBLY AS SHOWN.  
 NOTE 3: MOUNTING SURFACES WILL BE SQUARE AND CONCENTRIC WITH SHAFT WITHIN .004 T.I.R.  
 NOTE 4: D.E. ENDSHIELD ROTATED 90° COUNTER CLOCKWISE.  
 NOTE 5: ALL DIMENSIONS ARE IN INCHES, BRACKETED DIMENSIONS ARE IN METRIC (MILLIMETERS)

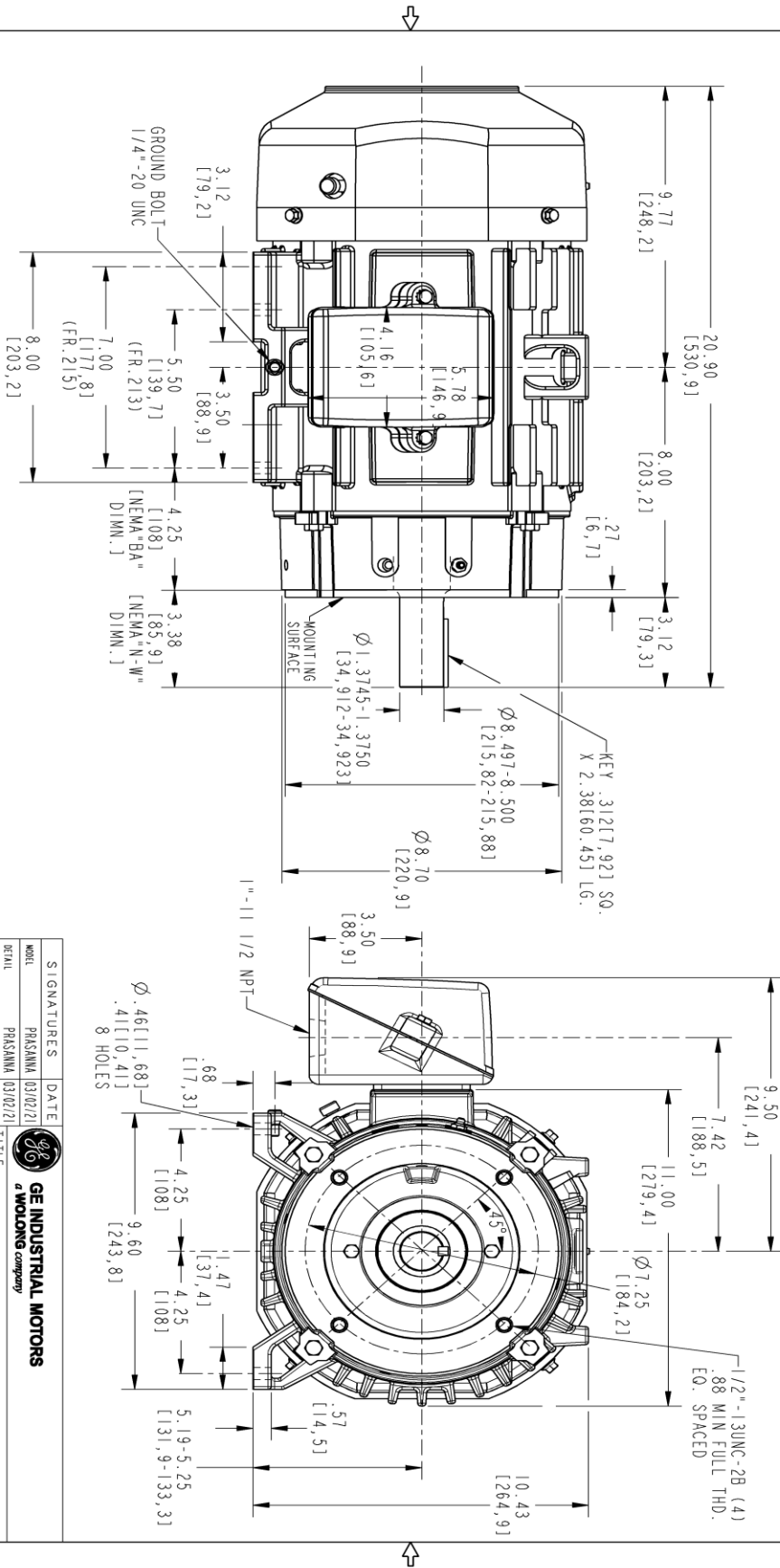

PROPRIETARY INFORMATION  
 © COPYRIGHT 2018 Wolog Electric America LLC AND/OR ITS AFFILIATES.  
 All rights reserved. This document and the information it contains is the property of Wolog Electric America LLC and/or its affiliates. It has been provided solely for the use of the customer for whom it is intended. No other use, reproduction, transmission, distribution, copying, or disclosure of this information is permitted without the express written consent of Wolog Electric America LLC. Any use of this information in writing is strictly prohibited except as expressly authorized in writing by Wolog Electric America LLC.

SIZE	DRAWING NO.	REV	SHEET
B	4002B5821PBP5820	000	1
REVISIONS			
REV.	DESCRIPTION	DATE	APPROVED

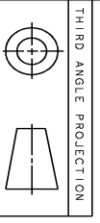

SIGNATURES	DATE	 <b>GE INDUSTRIAL MOTORS</b> <i>a Wolog company</i>
MODEL PRASMANA 03/02/21	03/02/21	
DETAIL PRASMANA 03/02/21	03/02/21	TITLE <b>INDUCTION MOTOR OUTLINE</b> XSD ULTRA, "C" FACE AT DE (85° RABEET) FR. 23TC/25 TC TERC. GROUND PAD
CREATOR RAGHU 03/02/21	03/02/21	
ENGR PRASMANA 03/02/21	03/02/21	
QC		
QUALITY		SIZE/DRAWING
ISSUED PRASMANA 03/02/21		B
SOLID MODEL: 4002B5821PBP5820	SCALE: 0.300	REV
	REF. No.: 4002B5821PBP5311	4002B5821PBP5820
		000
		SHEET 1 of 1

**Marks:**

**Connection Diagram**  
**GEM2034E-FIG7**



End shield Assembly		
Part Description	DE Side Part#	ODE Side Part#
End Shield	128D6006YB1	4004D5282SJ1
Bearing	235A2507EB01	235A2503AE01
Slinger/Inproseal	149C4399G02	149C4399G01

Fan & Fan Cover Assembly	
Part Description	Part#
Fan	159C6700G01
Fan Cover	4003C5787PA1

Conduit & Accessories Box Assembly	
Part Description	Part#
Conduit Box	4002B5721PA-G01

Mechanical Accessories	
Part Description	Part#
Brake	
Tachometer	

