



**GE INDUSTRIAL MOTORS**  
a **WOLONG** company

# Product Technical Information

August 14, 2021

Data shown is for the current revision model #. Ensure your nameplate model # matches.

<b>Model Number:</b>	<b>5KS254SAA208YQK</b>
<b>Catalog Number:</b>	<b>M9913</b>
<b>Instruction Manual:</b>	GEI-56128-SP
<b>Connection Diagram:</b>	GEM2034E-FIG7
<b>Outline Drawing:</b>	4002B5825PAP5992

## Accessory Connection Diagrams

<b>Bearing Thermocouple:</b>	None	<b>Heater:</b>	None
<b>RTD:</b>	None	<b>Thermistor:</b>	None
<b>Thermostat:</b>	None	<b>Winding Thermocouple:</b>	None
<b>Bearing RTD:</b>	None		

## Table of Contents

Specification	01
Performance Characteristics	02
Outline Drawing	03
Connection Drawing(s)	04
Spare parts	05

Marks:

<b>MODEL NUMBER:</b>	<b>5KS254SAA208YQK</b>	<b>Estimated Weight:</b>	315 Lbs
<b>Outline Drawing:</b>	4002B5825PAP5992	<b>Time Rating:</b>	CONT
<b>Connection Diagram:</b>	GEM2034E-FIG7	<b>Enclosure:</b>	TEFC
<b>Instruction Book:</b>	GEI-56128-SP	<b>Encl Construction:</b>	841
<b>Design Code:</b>	25BD1162A	<b>Ambient Max(°C):</b>	40
<b>Type:</b>	KS	<b>Alt Ambient Max(°C):</b>	--
<b>Frame:</b>	254T	<b>Insulation Class:</b>	H
<b>Phases:</b>	3	<b>NEMA Design:</b>	B
<b>Poles:</b>	4	<b>Nominal Efficiency:</b>	92.4 %
<b>Output Power:</b>	15HP 11.1KW	<b>Guaranteed Efficiency:</b>	91.7 %
<b>RPM:</b>	1775	<b>3/4 Load Efficiency:</b>	--
<b>Voltage:</b>	460	<b>KVA Code:</b>	G
<b>Hertz:</b>	60	<b>Max KVAR:</b>	6.1
<b>Amps - FL:</b>	18.9	<b>Power Factor:</b>	80.5
<b>Service Factor:</b>	1.15	<b>Bearing - DE:</b>	6309ZC3
<b>Alt Service Factor:</b>	--	<b>Bearing - ODE:</b>	6309ZC3

Enclosure is Totally Enclosed Fan-Cooled

---

Stamped Nameplate Notes:

IEEE-STD-841-2009

BALERO DE 45BC03JP30 BALERO ODE 45BC03JP30

STAMP NP249A5564P051 AS BELOW:

MODEL:5KS254SAA208YQK S/N: XXX

CSA CERTIFIED CSA09.2216219 FOR EX NA IIC 200C GC

CL 1 ZONE2 AEX NA IIC 200C;CL 1 DIV2 GRP ABCD 200C

IN -40C <= AMB <= 40C, 1.0 SF ON SINE-WAVE PWR

SURF TEMP 200C AT 1.15SF ON SINE-WAVE PWR

OR 200C VT OR 200C CT OR 200C CHP PWM CONTROL

ALTERNATE RATING FOR PWM CONTROL 1.0SF 40C AMB

VT 0 - 60 HZ, CT 3-60 HZ, CHP 60-90 HZ.

ESTANDAR DE REFERENCIA: NEMA-MG-1

ALTURA MAXIMA EN METROS: 1000 METROS

ANO DE MANUFACTURA: STAMP AS PER SAP

MASA: 143 KG

POSICION: HORIZONTAL

AMPERAJE/CORRIENTE DE ROTOR BLOQUEADO: 109.1 AMPS

TORQUE DE ROTOR BLOQUEADO: 124.1 N-M

TORQUE A PLENA CARGA: 60.2 N-M

MAXIMA VELOCIDAD DE OPERACION SEGURA: 3600 RPM

AMBIENTE MINIMO: -40 DEG C



**Additional Information:**

4P - T EXTN  
STANDARD FLOOR MOUNT  
C/BOX 137 CU IN-1.25 NPT  
F1 CONDUIT BOX MOUNTING  
PAINTED FRAME ID & SHAFT,  
FAN COVER INSIDE & ODE E/S OUTSIDE  
ROUTINE AND 5 POINT VIBRATION TESTS INCL IN C/BOX  
GROUND SCREW ON FRAME  
SHAFT RUNOUT LIMIT .001" TIR  
OIL RESISTANT SLEEVING ON LEADS  
RETIE/RETIQ CERTIFIED MOTOR



**Performance Characteristics**

1st Winding 1st Connection

**Design: 25BD1162A**

**Marks:**

LOAD %	125.0	115.0	100.0	75.0	50.0	25.0	0.0
% EFF	91.42	91.81	92.48	92.68	92.17	88.49	0.00
% PF	83.36	82.54	80.7	75.12	63.77	41.34	4.49
AMPS	23.03	21.3	18.81	15.12	11.94	9.6	8.55

<b>TORQ(FL)#FT</b>	44.38	<b>TORQ(LR)%FL</b>	206.19	<b>TORQ(BD)%FL</b>	273.88
<b>AMPS(LR)</b>	109.14	<b>PF AT START</b>	0.46		

This motor is capable of two cold or one hot start with a maximum connected load inertia of 457 Lb-Ft Sq (19.24 Kg-meter Sq)at 100% voltage, where the load torque varies with the square of the speed. Acceleration time with maximum inertia and the above load type is 38 seconds. Safe stall time at 100% voltage is 85 seconds cold, 54 seconds hot. Rotor inertia is 1.97 Lb-Ft Sq (0.08 Kg-meter Sq).

<b>Open Circuit A-C:</b>	0.386	<b>Short Circuit D-C:</b>	0.012
<b>Short Circuit A-C:</b>	0.023	<b>X/R Ratio:</b>	4.434
<b>Stator Slots:</b>	48	<b>Rotor Slots:</b>	40

**Speed Torque Current Curve (First Connection, First Speed)**

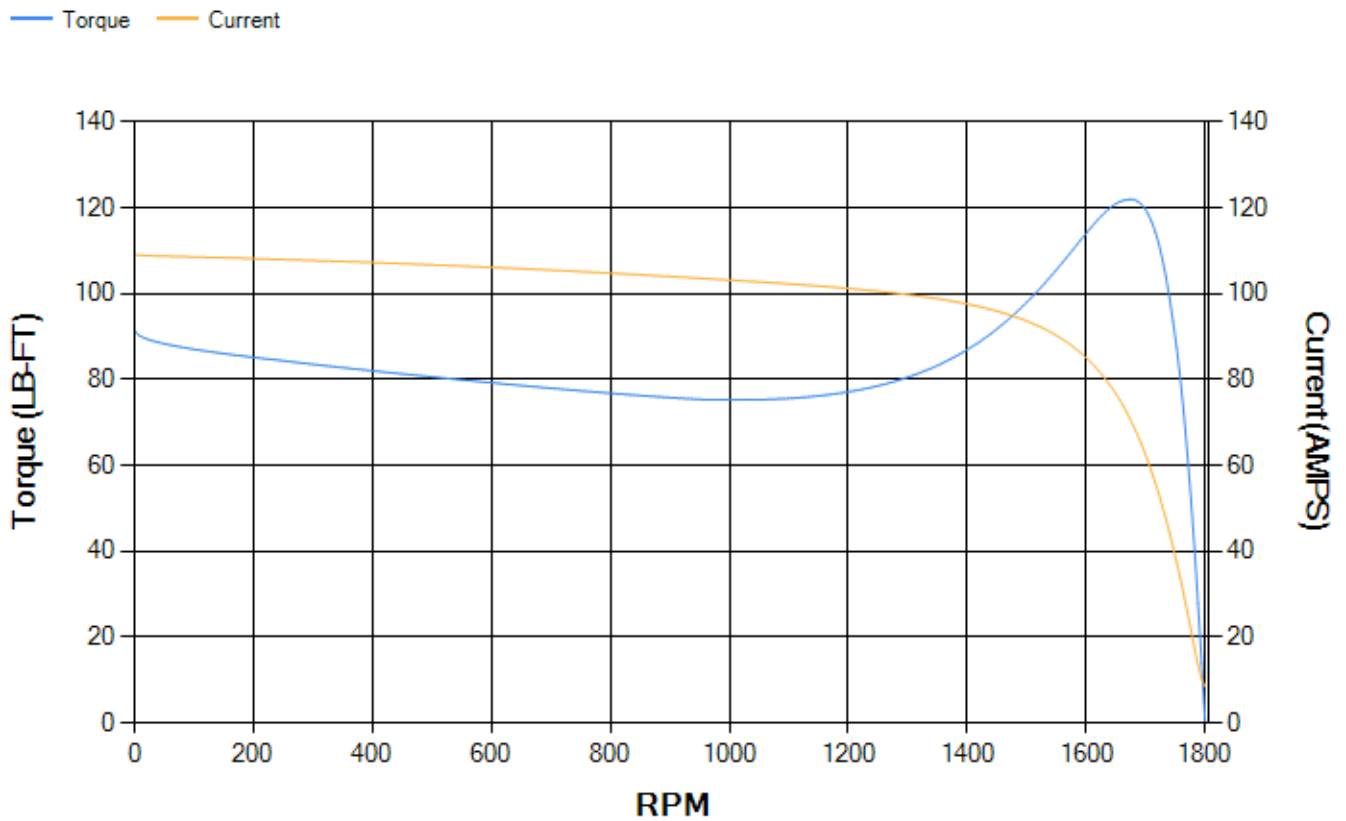

Marks:

NOTE 1: CONDUIT BOX MAY BE ASSEMBLED WITH ENTRANCE UP, DOWN OR TO EITHER SIDE.  
 NOTE 2: FIT ASSEMBLY AS SHOWN.  
 NOTE 3: ALL DIMENSIONS ARE IN INCHES, BRACKETED DIMENSIONS ARE IN METRIC (MILLIMETERS)

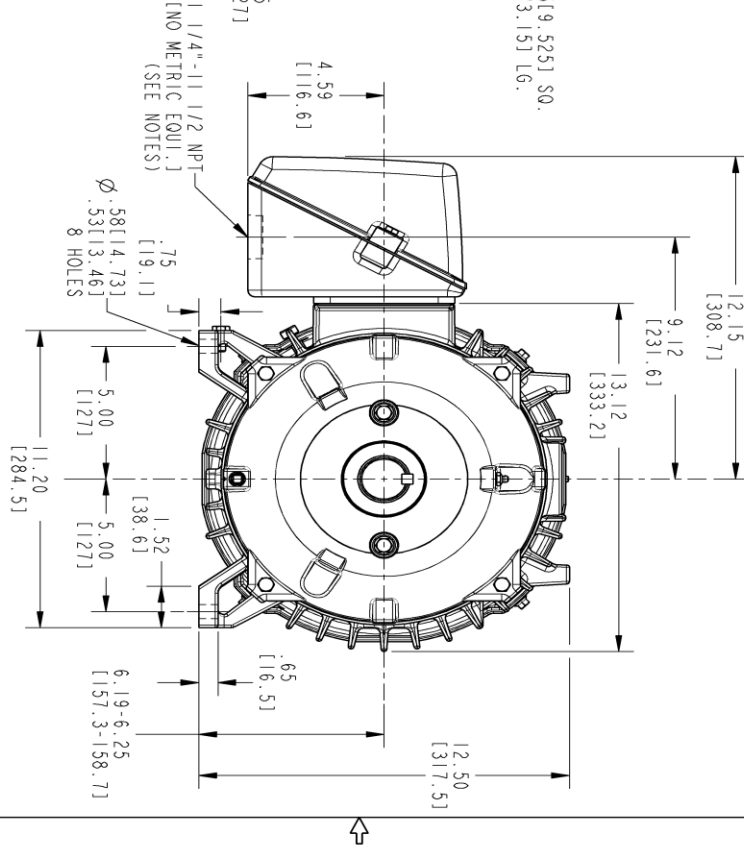
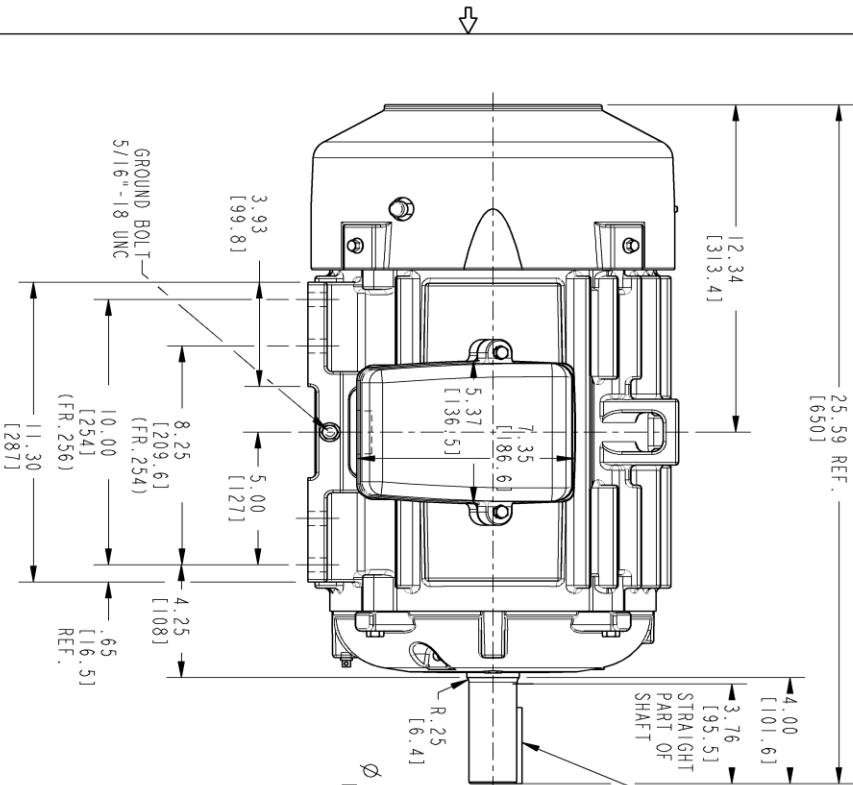

PROPRIETARY INFORMATION  
 All rights reserved. This document and the information it contains is the property of the Motor Electric America LLC and/or its affiliates. It has been provided solely for the use of the customer and is not to be distributed, copied, or otherwise used without the express written consent of Motor Electric America LLC. Any unauthorized use or disclosure is strictly prohibited except as expressly authorized in writing by Motor Electric America LLC.

REV.	DESCRIPTION	DATE	APPROVED
001	SAGAR K	03/24/21	VJ JAY

SIZE	DRAWING NO.	REV	SHEET
B	4002B5825PAP5992	001	1

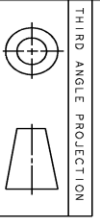

THIRD ANGLE PROJECTION

SIGNATURES	DATE	REV
PIVUSH	03/15/21	001
PIVUSH	03/15/21	
PIVUSH	03/15/21	
PIVUSH	03/15/21	

**GE INDUSTRIAL MOTORS**  
 a WOLONG company

**INDUCTION MOTOR OUTLINE**  
 STANDARD CONSTRUCTION, GROUND PAD  
 FMR, FR250T TFC

SCALE: 0.250 REF. No.: 4002B5825PAP5992

**4002B5825PAP5992**

Marks:

**Connection Diagram**  
**GEM2034E-FIG7**



End shield Assembly		
Part Description	DE Side Part#	ODE Side Part#
End Shield		
Bearing		
Slinger/Inproseal		

Fan & Fan Cover Assembly	
Part Description	Part#
Fan	
Fan Cover	

Conduit & Accessories Box Assembly	
Part Description	Part#
Conduit Box	

Mechanical Accessories	
Part Description	Part#
Brake	
Tachometer	

