



GE INDUSTRIAL MOTORS
a **WOLONG** company

Product Technical Information

February 19, 2021

Data shown is for the current revision model #. Ensure your nameplate model # matches.

Model Number:	5KS324SAA208D11
Catalog Number:	M9915
Instruction Manual:	GEI-56128
Connection Diagram:	GEM2034E-FIG7
Outline Drawing:	239C6000BC

Accessory Connection Diagrams

Bearing Thermocouple:	None	Heater:	None
RTD:	None	Thermistor:	None
Thermostat:	None	Winding Thermocouple:	None
Bearing RTD:	None		

Table of Contents

Specification	01
Performance Characteristics	02
Outline Drawing	03
Connection Drawing(s)	04
Spare parts	05

Marks:

MODEL NUMBER:	5KS324SAA208D11	Estimated Weight:	670 Lbs
Outline Drawing:	239C6000BC	Time Rating:	CONT
Connection Diagram:	GEM2034E-FIG7	Enclosure:	TEFC
Instruction Book:	GEI-56128	Encl Construction:	841
Design Code:	32BD1182A	Ambient Max(°C):	40
Type:	KS	Alt Ambient Max(°C):	--
Frame:	324T	Insulation Class:	H
Phases:	3	NEMA Design:	B
Poles:	4	Nominal Efficiency:	94.1 %
Output Power:	40HP 29.6KW	Guaranteed Efficiency:	93.6 %
RPM:	1780	3/4 Load Efficiency:	--
Voltage:	460	KVA Code:	G
Hertz:	60	Max KVAR:	15.2
Amps - FL:	49.7	Power Factor:	80.0
Service Factor:	1.15	Bearing - DE:	6312ZC3
Alt Service Factor:	--	Bearing - ODE:	6312ZC3

Enclosure is Totally Enclosed Fan-Cooled

Stamped Nameplate Notes:

IEEE-STD-841-2009

DE BRG 60BC03JP30, ODE BRG 60BC03JP30

STAMP NP249A5564P051 AS BELOW:

MODEL:5KS324SAA208D11 S/N: XXX

CSA CERTIFIED CSA09.2216219 FOR EX NA IIC 200 C GC

CL 1 ZONE2 AEX NA IIC 200C;CL 1 DIV2 GRP ABCD 200C

IN -40C <= AMB <= 40C, 1.0 SF ON SINE-WAVE PWR

SURF TEMP 230C AT 1.15SF ON SINE-WAVE PWR

OR 200C VT OR 230C CT OR 200C CHP PWM CONTROL

ALTERNATE RATING FOR PWM CONTROL 1.0SF 40C AMB

VT 0 - 60 HZ, CT 3 - 60 HZ, CHP 60 - 90 HZ.



Additional Information:

4P - T EXTN
PAINTED FRAME ID & SHAFT,
FAN COVER INSIDE & ODE E/S OUTSIDE
C/BOX 346 CU IN - 3.00" NPT
OIL RESISTANT SLEEVING ON LEADS
.0015" TIR SHAFT RUNOUT
ROUTINE TEST REPORT AND 5 POINT VIBRATION TEST
REPORT INCLUDED IN C/B
GROUND PAD
F1 MOUNTING



Performance Characteristics

1st Winding 1st Connection

Design: 32BD1182A

Marks:

LOAD %	125.0	115.0	100.0	75.0	50.0	25.0	0.0
% EFF	93.44	93.73	94.29	94.38	93.95	91	0.00
% PF	82.18	81.61	80.15	75.28	64.7	42.44	3.55
AMPS	60.94	56.28	49.43	39.52	30.79	24.24	21.17

TORQ(FL)#FT	118.11	TORQ(LR)%FL	162.85	TORQ(BD)%FL	242.14
AMPS(LR)	267.59	PF AT START	0.33		

This motor is capable of two cold or one hot start with a maximum connected load inertia of 952 Lb-Ft Sq (40.08 Kg-meter Sq)at 100% voltage, where the load torque varies with the square of the speed. Acceleration time with maximum inertia and the above load type is 40 seconds. Safe stall time at 100% voltage is 88 seconds cold, 47 seconds hot. Rotor inertia is 6.94 Lb-Ft Sq (0.29 Kg-meter Sq).

Open Circuit A-C:	0.479	Short Circuit D-C:	0.022
Short Circuit A-C:	0.032	X/R Ratio:	8.428
Stator Slots:	48	Rotor Slots:	38

Speed Torque Current Curve (First Connection, First Speed)

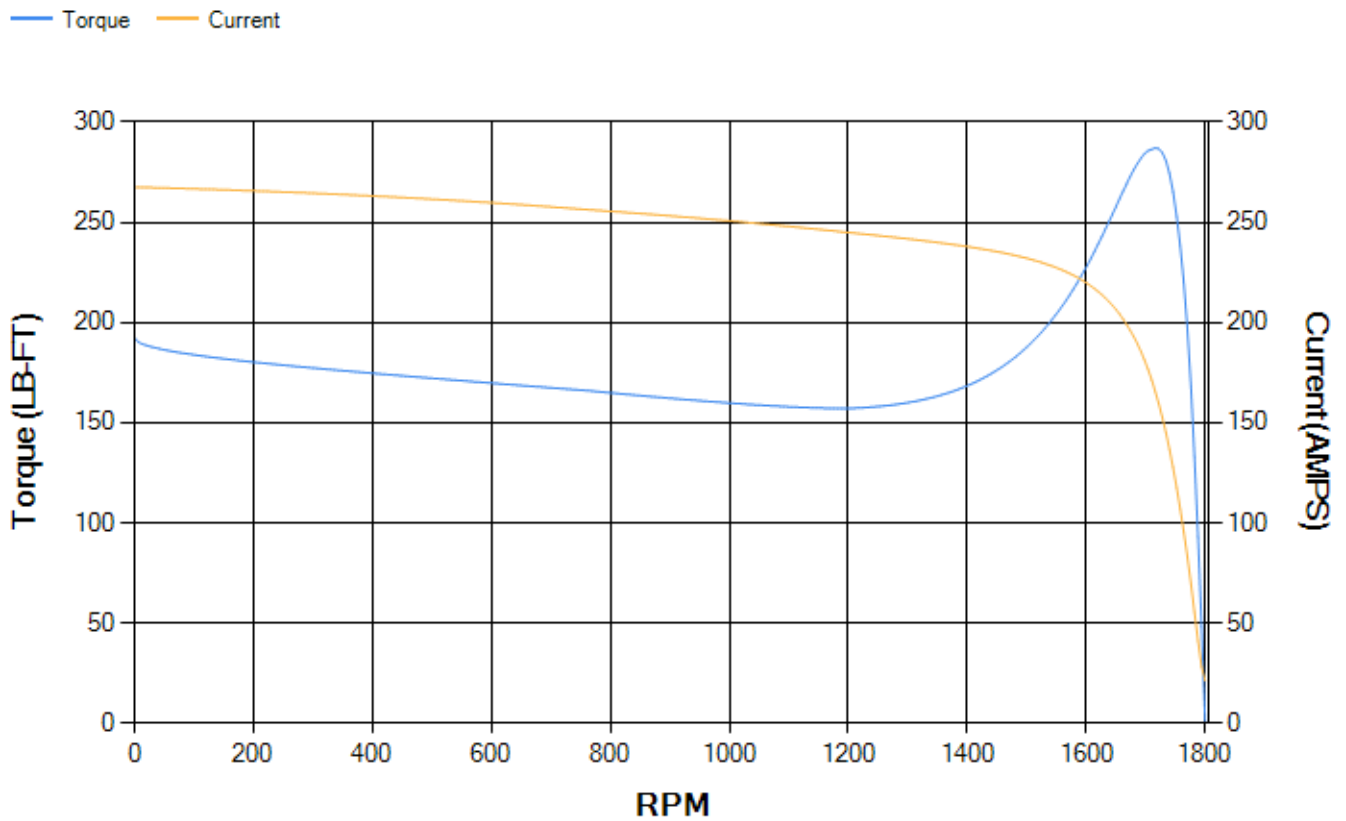

NAME: 103013435 OBJECT: 239C6000BC DATE: 02-May-03 16:11:49

239C6000BC
ASSEMB

Marks:

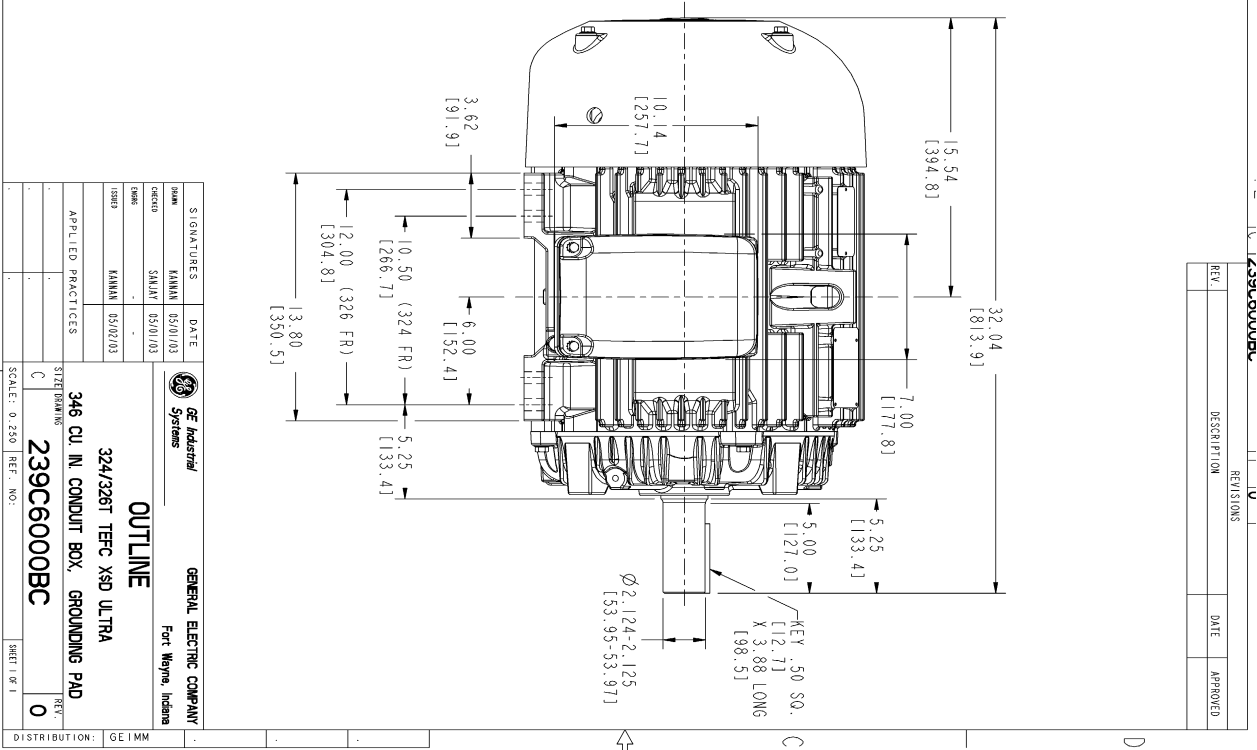
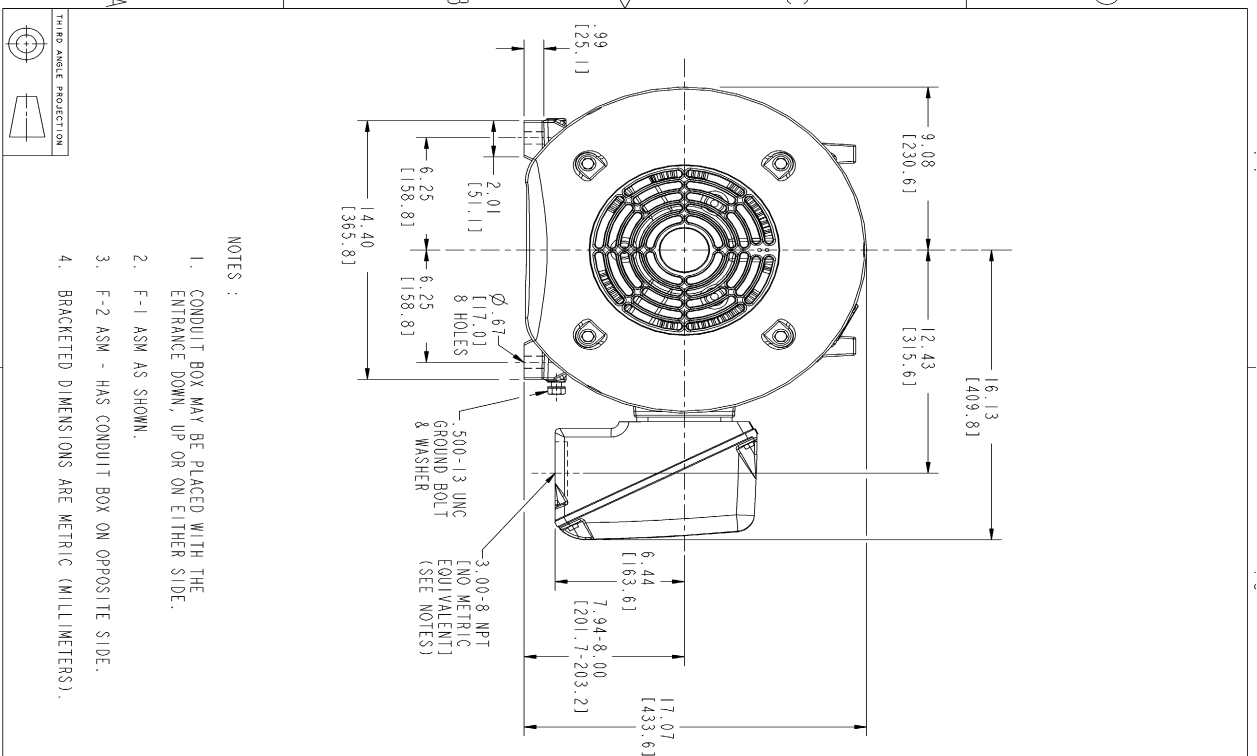

- NOTES :
1. CONDUIT BOX MAY BE PLACED WITH THE ENTRANCE DOWN, UP OR ON EITHER SIDE.
 2. F-1 ASM AS SHOWN.
 3. F-2 ASM - HAS CONDUIT BOX ON OPPOSITE SIDE.
 4. BRACKETED DIMENSIONS ARE METRIC (MILLIMETERS).

REV	DESCRIPTION	DATE	APPROVED

DATE	DATE	DATE	DATE
05/01/03	05/01/03	05/01/03	05/01/03
SKALNY	SKALNY	SKALNY	SKALNY

APPLIED PRACTICES	STRENGTH

SCALE: 0.250	REF. NO.:

346 CU IN CONDUIT BOX, GROUNDING PAD	324/326T TFC XSD ULTRA
239C6000BC	

GENERAL ELECTRIC COMPANY	GE Industrial Systems
Fort Wayne, Indiana	

OUTLINE

SHEET 1 OF 1

DISTRIBUTION: GE IMM

Marks:

Connection Diagram
GEM2034E-FIG7



End shield Assembly		
Part Description	DE Side Part#	ODE Side Part#
End Shield	115E4200AA1	115E4200LA1
Bearing	235A2509AS01	235A2509AS01
Slinger/Inproseal	149C4399G04	149C4399G04

Fan & Fan Cover Assembly	
Part Description	Part#
Fan	159C6900G04
Fan Cover	128D6800AA1

Conduit & Accessories Box Assembly	
Part Description	Part#
Conduit Box	149C4429AA2

Mechanical Accessories	
Part Description	Part#
Brake	
Tachometer	

