



**GE INDUSTRIAL MOTORS**  
a **WOLONG** company

# Product Technical Information

February 19, 2021

Data shown is for the current revision model #. Ensure your nameplate model # matches.

<b>Model Number:</b>	<b>5KS445SAA218D7</b>
<b>Catalog Number:</b>	<b>M9929</b>
<b>Instruction Manual:</b>	GEI-56128
<b>Connection Diagram:</b>	GEM2034E-FIG1
<b>Outline Drawing:</b>	239C6600ALD

## Accessory Connection Diagrams

<b>Bearing Thermocouple:</b>	None	<b>Heater:</b>	None
<b>RTD:</b>	None	<b>Thermistor:</b>	None
<b>Thermostat:</b>	None	<b>Winding Thermocouple:</b>	None
<b>Bearing RTD:</b>	None		

## Table of Contents

Specification	01
Performance Characteristics	02
Outline Drawing	03
Connection Drawing(s)	04
Spare parts	05

Marks:

**MODEL NUMBER:** 5KS445SAA218D7  
**Outline Drawing:** 239C6600ALD  
**Connection Diagram:** GEM2034E-FIG1  
**Instruction Book:** GEI-56128  
**Design Code:** 44BD1174A  
**Type:** KS  
**Frame:** 445TS  
**Phases:** 3  
**Poles:** 4  
**Output Power:** 150HP 111KW  
**RPM:** 1785  
**Voltage:** 460  
**Hertz:** 60  
**Amps - FL:** 168.0  
**Service Factor:** 1.15  
**Alt Service Factor:** --

**Estimated Weight:** 2060 Lbs  
**Time Rating:** CONT  
**Enclosure:** TEFC  
**Encl Construction:** 841  
**Ambient Max(°C):** 40  
**Alt Ambient Max(°C):** --  
**Insulation Class:** H  
**NEMA Design:** B  
**Nominal Efficiency:** 95.8 %  
**Guaranteed Efficiency:** 95.4 %  
**3/4 Load Efficiency:** --  
**KVA Code:** G  
**Max KVAR:** 40.4  
**Power Factor:** 87.0  
**Bearing - DE:** 6318ZC3  
**Bearing - ODE:** 6318ZC3

**Enclosure is Totally Enclosed Fan-Cooled**

---

Stamped Nameplate Notes:

IEEE-STD-841-2009  
 DE BRG 90BC03JP3, ODE BRG 90BC03JP3  
 STAMP NP249A5564P051 AS BELOW:  
 MODEL:5KS445SAA218D7 S/N: XXX  
 CSA CERTIFIED CSA09.2216219 FOR EX NA IIC 200 C GC  
 CL 1 ZONE2 AEX NA IIC 200C;CL 1 DIV2 GRP ABCD 200C  
 IN -40C <= AMB <= 40C, 1.0 SF ON SINE-WAVE PWR  
 SURF TEMP 200C AT 1.15SF ON SINE-WAVE PWR  
 OR 200C VT OR 230C CT OR 200C CHP PWM CONTROL  
 ALTERNATE RATING FOR PWM CONTROL 1.0SF 40C AMB  
 VT 0 - 60 HZ, CT 15-60 HZ, CHP 60-90 HZ.



**Additional Information:**

4P - TS EXTN  
PAINTED FRAME ID & SHAFT,  
FAN COVER INSIDE & ODE E/S OUTSIDE  
C/BOX 700 CU IN - 3.00" NPT  
OIL RESISTANT SLEEVING ON LEADS  
.0015" TIR SHAFT RUNOUT  
ROUTINE TEST REPORT AND 5 POINT VIBRATION TEST  
REPORT INCLUDED IN C/B  
GROUND PAD  
F1 MOUNTING



**Performance Characteristics**

1st Winding 1st Connection

**Design: 44BD1174A**

**Marks:**

LOAD %	125.0	115.0	100.0	75.0	50.0	25.0	0.0
% EFF	95.32	95.48	95.85	95.71	95.18	92.53	0.00
% PF	88.06	87.76	86.89	83.67	75.62	54.28	4.43
AMPS	209.06	192.69	168.57	131.49	97.52	69.87	56.28

<b>TORQ(FL)#FT</b>	441.48	<b>TORQ(LR)%FL</b>	201.51	<b>TORQ(BD)%FL</b>	275.25
<b>AMPS(LR)</b>	1083.73	<b>PF AT START</b>	0.33		

This motor is capable of two cold or one hot start with a maximum connected load inertia of 3239 Lb-Ft Sq (136.36 Kg-meter Sq)at 100% voltage, where the load torque varies with the square of the speed. Acceleration time with maximum inertia and the above load type is 30 seconds. Safe stall time at 100% voltage is 58 seconds cold, 37 seconds hot. Rotor inertia is 71.16 Lb-Ft Sq (3 Kg-meter Sq).

<b>Open Circuit A-C:</b>	0.856	<b>Short Circuit D-C:</b>	0.033
<b>Short Circuit A-C:</b>	0.04	<b>X/R Ratio:</b>	12.52
<b>Stator Slots:</b>	72	<b>Rotor Slots:</b>	58

**Speed Torque Current Curve (First Connection, First Speed)**

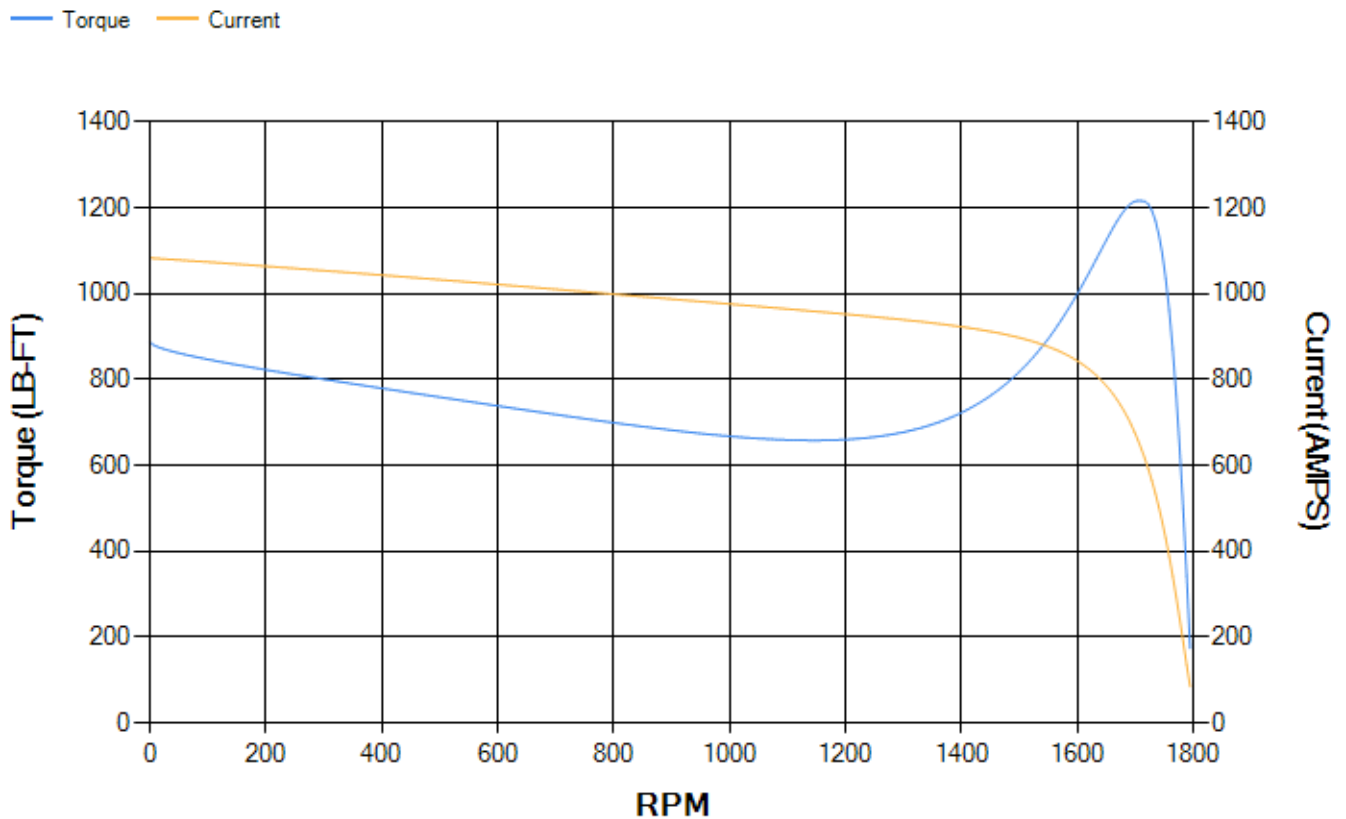

Marks:

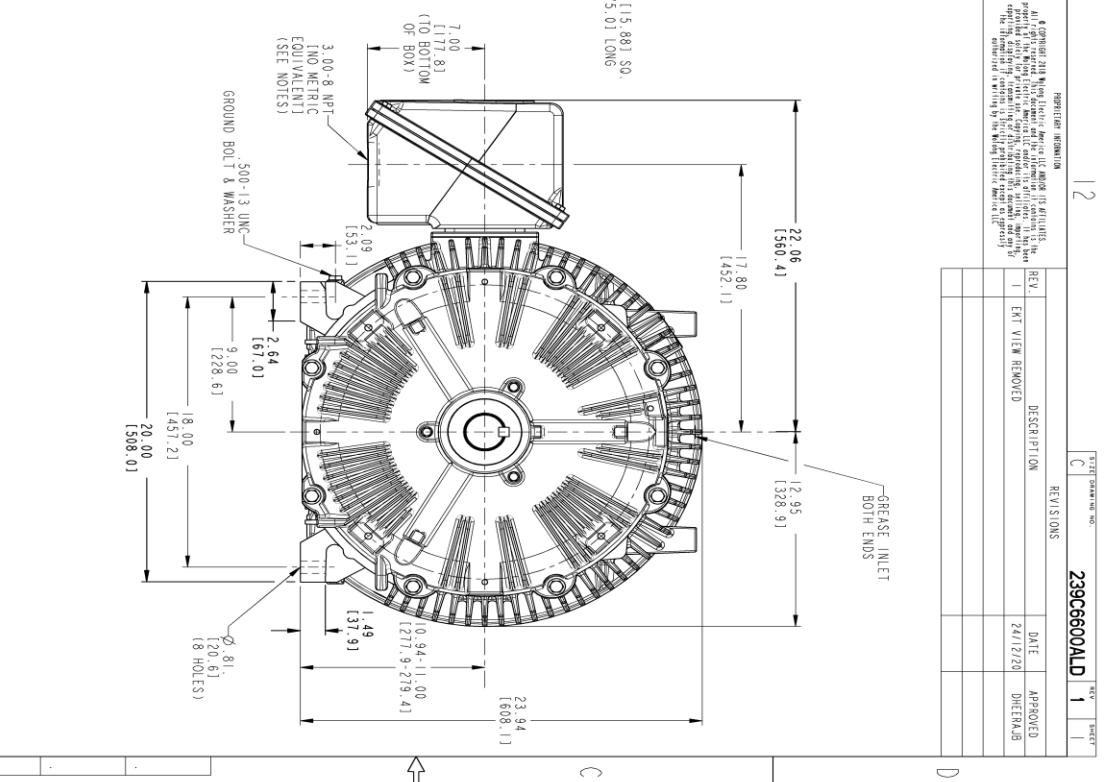
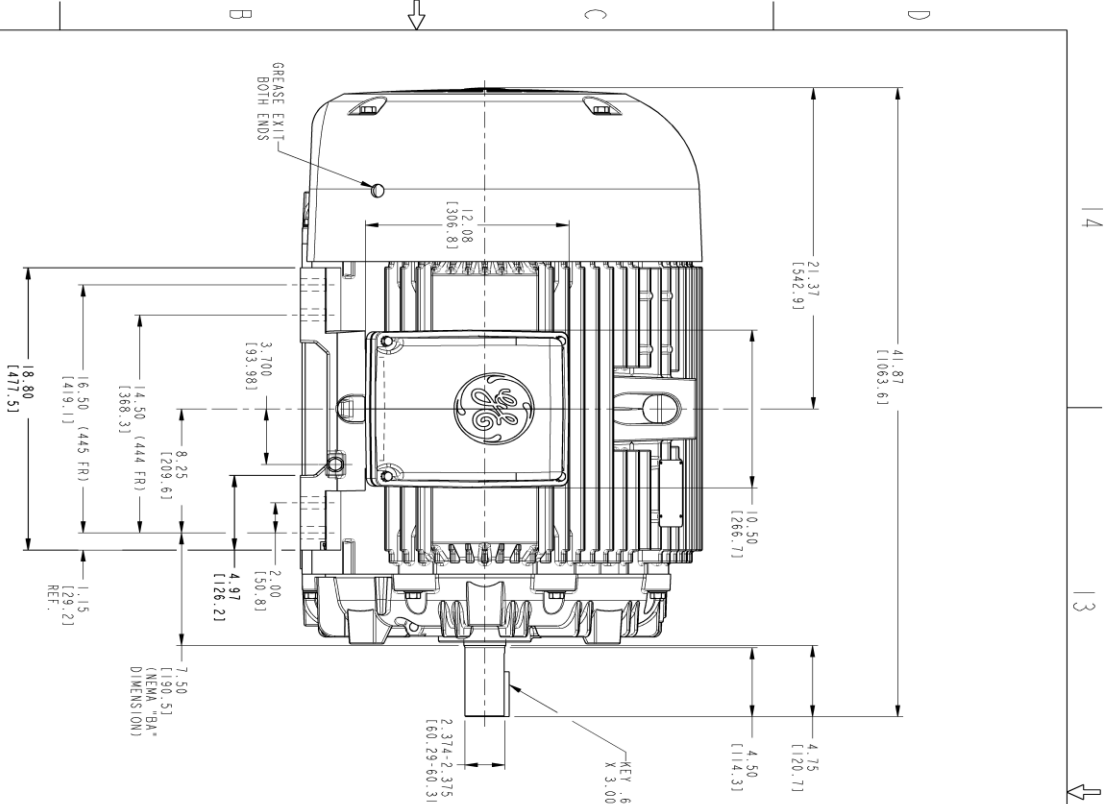

REVISION INFORMATION

REV.	DESCRIPTION	DATE	APPROVED
1	EXP VIEW REMOVED	2/11/20	DIERHAB

SIGNATURES	DATE
DIERHAB 2/11/2020	
DIERHAB 2/11/2020	
DIERHAB 2/11/2020	
DIERHAB 2/11/2020	
DIERHAB 2/11/2020	
DIERHAB 2/11/2020	

- NOTES:
1. CONDUIT BOX MAY BE PLACED WITH THE ENTRANCE DOWN, UP OR ON EITHER SIDE.
  2. F-1 ASSEMBLY AS SHOWN.
  3. ALL DIMENSIONS ARE IN INCHES & BRACKETED DIMENSIONS ARE METRIC (MILLIMETERS).



MODEL	SIGNATURES	DATE	TITLE
5KS445SAA218D7	DIERHAB	2/11/2020	OUTLINE
444/445 TS TERC XSD			
700 CU IN C BOX, GROUND BOLT			

DISTRIBUTION: MMP

**Marks:**

**Connection Diagram**  
**GEM2034E-FIG1**



## End shield Assembly

Part Description	DE Side Part#	ODE Side Part#
End Shield	115E4355AA1	115E4355LM1
Bearing	235A2514AG01	235A2514AG01
Slinger/Inproseal	149C4399G07	149C4399G07

## Fan &amp; Fan Cover Assembly

Part Description	Part#
Fan	159C7100G02
Fan Cover	128D6841AA1

## Conduit &amp; Accessories Box Assembly

Part Description	Part#
Conduit Box	118D4408AD2

## Mechanical Accessories

Part Description	Part#
Brake	
Tachometer	

