



GE INDUSTRIAL MOTORS
a **WOLONG** company

Product Technical Information

April 29, 2021

Data shown is for the current revision model #. Ensure your nameplate model # matches.

Model Number:	5KS256SAA300D1
Catalog Number:	M9956
Instruction Manual:	GEI-56128
Connection Diagram:	GEM2034E-FIG1
Outline Drawing:	4002B5825PBP5926

Accessory Connection Diagrams

Bearing Thermocouple:	None	Heater:	None
RTD:	None	Thermistor:	None
Thermostat:	None	Winding Thermocouple:	None
Bearing RTD:	None		

Table of Contents

Specification	01
Performance Characteristics	02
Outline Drawing	03
Connection Drawing(s)	04
Spare parts	05

Marks:

MODEL NUMBER:	5KS256SAA300D1	Estimated Weight:	350 Lbs
Outline Drawing:	4002B5825PBP5926	Time Rating:	CONT
Connection Diagram:	GEM2034E-FIG1	Enclosure:	TEFC
Instruction Book:	GEI-56128	Encl Construction:	841
Design Code:	25BD3100A	Ambient Max(°C):	40
Type:	KS	Alt Ambient Max(°C):	--
Frame:	256TC	Insulation Class:	H
Phases:	3	NEMA Design:	B
Poles:	6	Nominal Efficiency:	91.0 %
Output Power:	10HP 7.4KW	Guaranteed Efficiency:	90.2 %
RPM:	1175	3/4 Load Efficiency:	--
Voltage:	460	KVA Code:	H
Hertz:	60	Max KVAR:	4.2
Amps - FL:	13.0	Power Factor:	79.0
Service Factor:	1.15	Bearing - DE:	6310ZC3
Alt Service Factor:	--	Bearing - ODE:	6309ZC3

Enclosure is Totally Enclosed Fan-Cooled

Stamped Nameplate Notes:

IEEE-STD-841-2009

DE BRG 50BC03JP30 ODE BRG 45BC03JP30

STAMP NP249A5564P051 AS BELOW:

MODEL:5KS256SAA300D1 S/N: XXX

CSA CERTIFIED CSA09.2216219 FOR EX NA IIC 200C GC

CL 1 ZONE2 AEX NA IIC 200C;CL 1 DIV2 GRP ABCD 200C

IN -40C <= AMB <= 40C, 1.0 SF ON SINE-WAVE PWR

SURF TEMP 200C AT 1.15SF ON SINE-WAVE PWR

OR 200C VT OR 200C CT OR 200C CHP PWM CONTROL

ALTERNATE RATING FOR PWM CONTROL 1.0SF 40C AMB

VT 0-60 HZ, CT 3-60 HZ, CHP 60-90 HZ.



Additional Information:

6P - T EXTN
STANDARD FLOOR MOUNT
C/BOX 137 CU IN-1.25 NPT
F1 CONDUIT BOX MOUNTING
"C" FACE AT DE ENDSHIELD
PAINTED FRAME ID & SHAFT,
FAN COVER INSIDE & ODE E/S OUTSIDE
ROUTINE AND 5 POINT VIBRATION TESTS INCL IN C/BOX
GROUND SCREW ON FRAME
ROTATE D.E. E/SHIELD 90 DEG. PER OUTLINE
SHAFT RUNOUT LIMIT .001" TIR
OIL RESISTANT SLEEVING ON LEADS



Performance Characteristics

1st Winding 1st Connection

Design: 25BD3100A

Marks:

LOAD %	125.0	115.0	100.0	75.0	50.0	25.0	0.0
% EFF	90.18	90.66	91.45	91.79	91.32	87.41	0.00
% PF	81.81	80.99	79.13	73.48	62.17	40.31	4.8
AMPS	15.86	14.66	12.94	10.41	8.24	6.64	5.89

TORQ(FL)#FT	44.74	TORQ(LR)%FL	215.09	TORQ(BD)%FL	286.64
AMPS(LR)	83.8	PF AT START	0.41		

This motor is capable of two cold or one hot start with a maximum connected load inertia of 976 Lb-Ft Sq (41.09 Kg-meter Sq)at 100% voltage, where the load torque varies with the square of the speed. Acceleration time with maximum inertia and the above load type is 43 seconds. Safe stall time at 100% voltage is 96 seconds cold, 66 seconds hot. Rotor inertia is 1.99 Lb-Ft Sq (0.08 Kg-meter Sq).

Open Circuit A-C:	0.249	Short Circuit D-C:	0.011
Short Circuit A-C:	0.015	X/R Ratio:	4.232
Stator Slots:	54	Rotor Slots:	42

Speed Torque Current Curve (First Connection, First Speed)

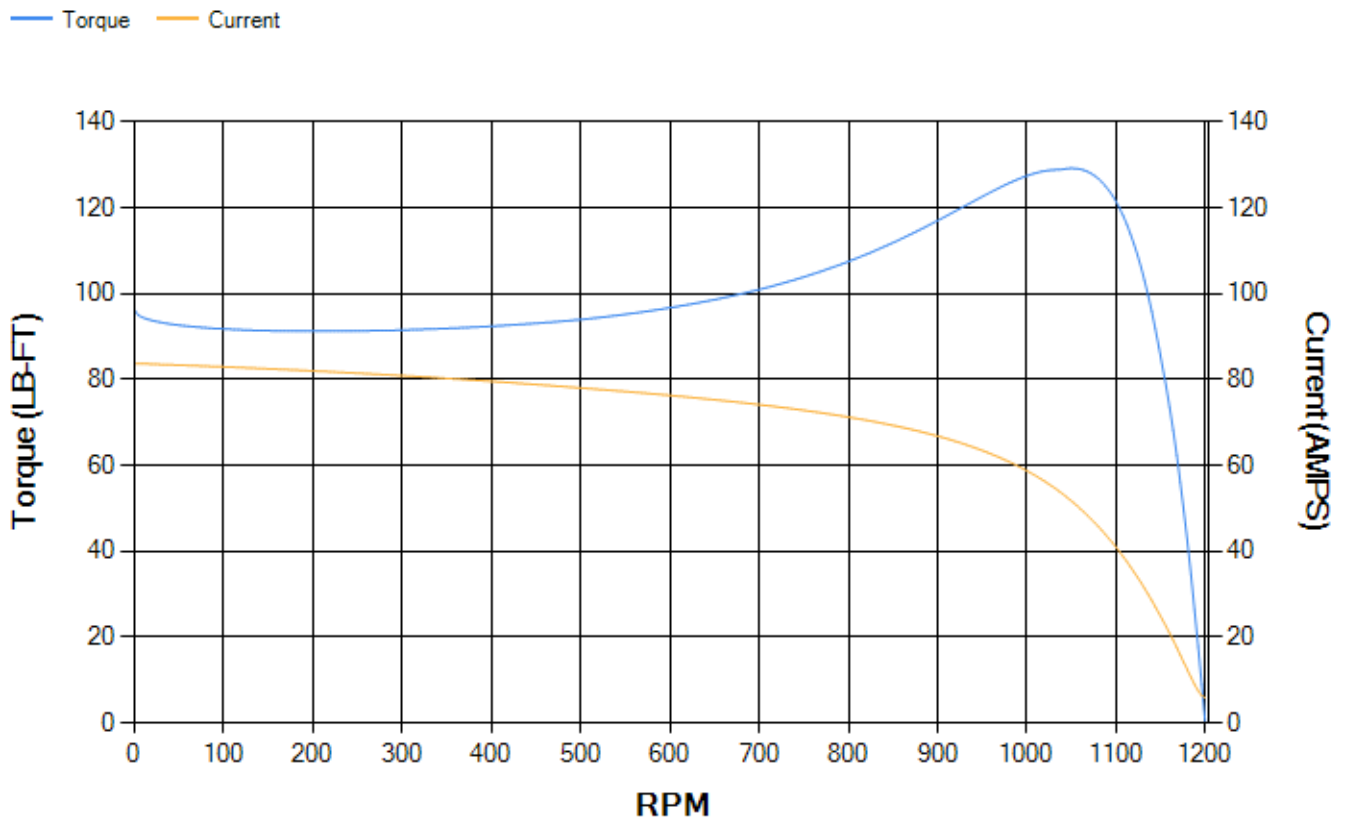

Marks:

- NOTE 1: CONDUIT BOX MAY BE ASSEMBLED WITH ENTRANCE UP, DOWN OR TO EITHER SIDE.
- NOTE 2: F1 ASSEMBLY AS SHOWN.
- NOTE 3: MOUNTING SURFACES WILL BE SQUARE AND CONCENTRIC WITH SHAFT WITHIN .004 T.I.R.
- NOTE 4: SHAFT RUNOUT WILL NOT EXCEED .001 T.I.R.
- NOTE 5: DE ENDSHIELD ROTATED 90° COUNTER CLOCKWISE
- NOTE 6: ALL DIMENSIONS ARE IN INCHES, BRACKETED DIMENSIONS ARE IN METRIC (MILLIMETERS)

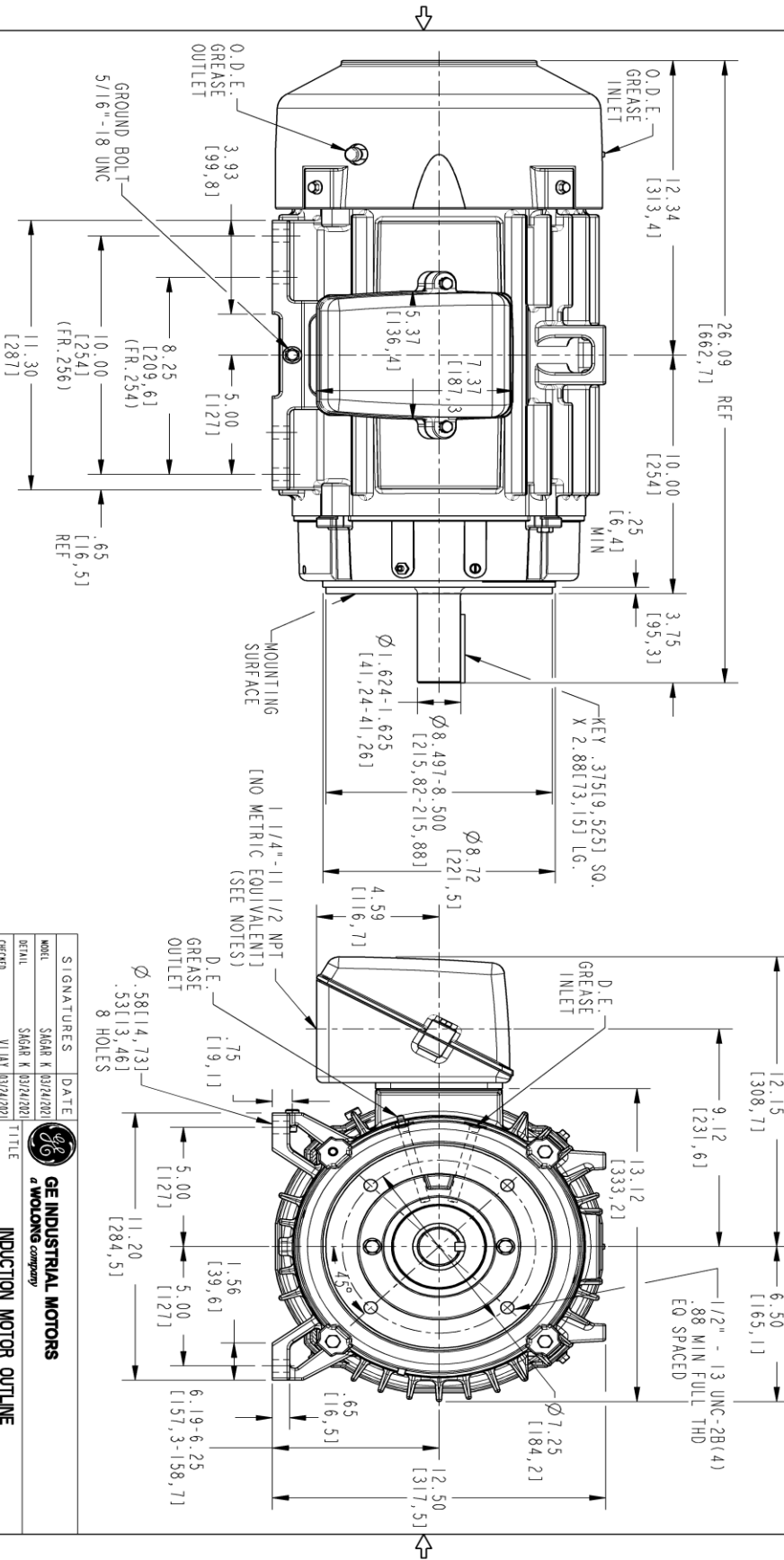

PROPRIETARY INFORMATION
 © COPYRIGHT 2018 Wolog Electric America LLC AND/OR ITS AFFILIATES.
 All rights reserved. This document and the information it contains is the property of Wolog Electric America LLC and/or its affiliates. It has been provided solely for the use of the recipient for the specific project and any other use, reproduction, transmission, distribution, or disclosure of this information, in any form or by any means, is strictly prohibited except as expressly authorized in writing by Wolog Electric America LLC.

REV.	DESCRIPTION	DATE	APPROVED

SIZE	DRAWING NO.	REV	SHEET
B	4002B5825PBP5926	000	1

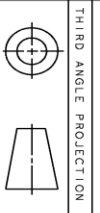

THIRD ANGLE PROJECTION

SIGNATURES	DATE	TITLE
SAGAR K [03/24/2021]		INDUCTION MOTOR OUTLINE
SAGAR K [03/24/2021]		FR. 254/2561TC TFC, "C" FACE AT DRIVE END (85° RABBIT)
SAGAR K [03/24/2021]		137 CU IN. C/BOX, GROUND PAD
SAGAR K [03/24/2021]		
SAGAR K [03/24/2021]		
SAGAR K [03/24/2021]		
SAGAR K [03/24/2021]		
SAGAR K [03/24/2021]		
SAGAR K [03/24/2021]		

GE INDUSTRIAL MOTORS
 a Wolog company

SCALE: 0.250 REF. No.: 4002B5825PBP5926

4002B5825PBP5926

000

Marks:

Connection Diagram
GEM2034E-FIG1



End shield Assembly		
Part Description	DE Side Part#	ODE Side Part#
End Shield	128D6106RF1	4004D5283SE1
Bearing	235A2508EC01	235A2507EB01
Slinger/Inproseal	149C4399G03	149C4399G02

Fan & Fan Cover Assembly	
Part Description	Part#
Fan	159C6800G01
Fan Cover	4003C5788PA1

Conduit & Accessories Box Assembly	
Part Description	Part#
Conduit Box	4002B5728PA-G04

Mechanical Accessories	
Part Description	Part#
Brake	
Tachometer	

