

DATE MARCH. 4, 2020	OUTLINE DIMENSIONS  3-PHASE INDUCTION MOTOR	MOTOR TYPE: AEHH8P
DATE NP0104		FRAME NO. 215T

Pole	HP	kW	Hz	VOLT	r/min (rpm)
4	10	7.5	60	230/460	1800

Ins	Rating	Dimension in	Approx Weight	Bearings
F	CONT.	Inch	170 lbs	DE: 6308ZZ NDE: 6306ZZ

Totally Enclosed Fan-Cooled Type. Squirrel-Cage Rotor.

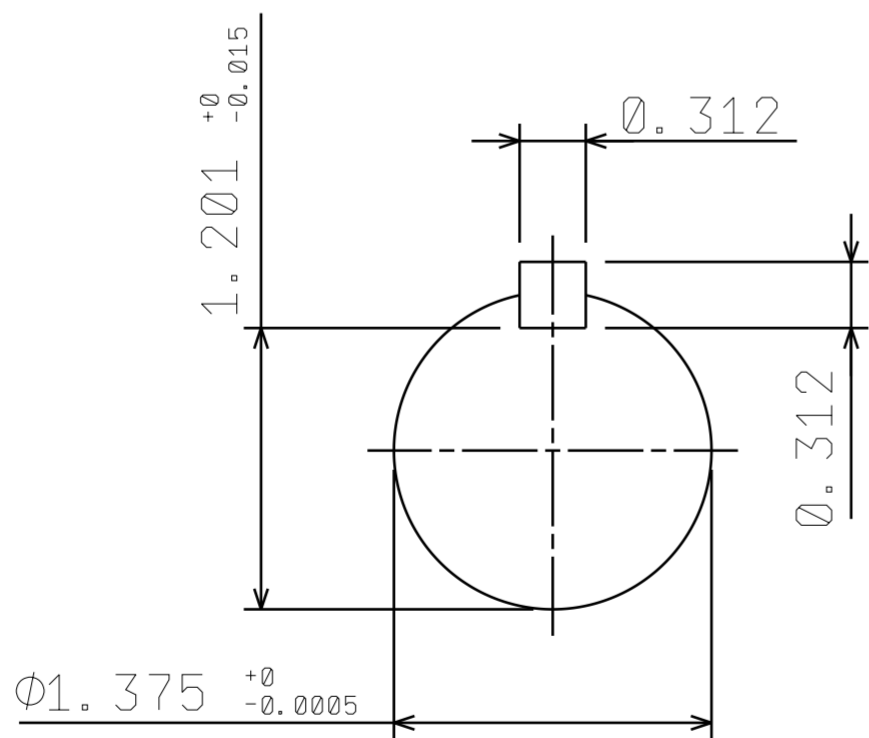
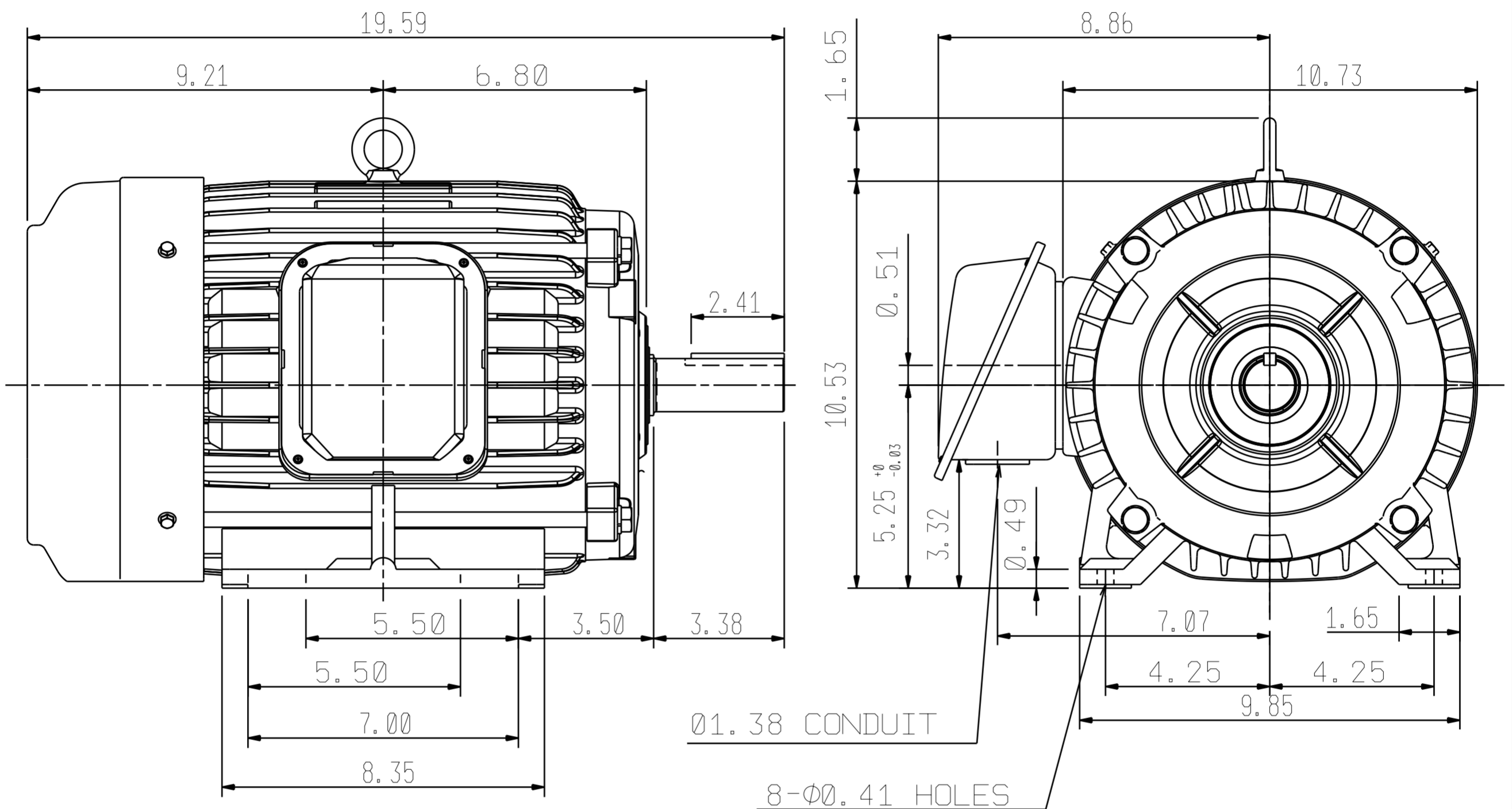

② 07 19 19	Modified Dimesions	Mahato
------------	--------------------	--------

DWG.	Mahato	12 •28 18
CHKD.	M. C. JENG	05 •30 19
APPD.	M. C. JENG	05 •30 19



DWG NO.	31049R344012
---------	--------------

# TECO Westinghouse

ISSUED <b>07/23/19</b>	<b>PERFORMANCE DATA</b>	ENCLOSURE <b>TEFC</b>
TYPE <b>AEHH8P</b>		CATALOG# <b>NP0104</b>
<b>3-PHASE INDUCTION MOTOR</b>		

## NAMEPLATE INFORMATION

OUTPUT		POLE	FRAME SIZE	VOLTAGE	HZ	RATED AMBIEN	INS. CLASS	NEMA DESIGN	TIME RATING	SERVICE FACTOR
HP	KW									
<b>10</b>	<b>7.5</b>	<b>4</b>	<b>215T</b>	<b>460</b>	<b>60</b>	<b>40°C</b>	<b>F</b>	<b>B</b>	<b>CONT.</b>	<b>1.15</b>

## TYPICAL PERFORMANCE

FULL LOAD RPM	EFFICIENCY				POWER FACTOR			MAXIMUM POWER FACTOR CORRECTION
	FULL LOAD		3/4 LOAD %	1/2 LOAD	F. L. %	3/4 LOAD	1/2 LOAD	
	NOM. %	MIN. %						
<b>1765</b>	<b>91.7</b>	<b>90.2</b>	<b>91.0</b>	<b>91.0</b>	<b>83.0</b>	<b>79.0</b>	<b>69.5</b>	<b>2.16 KVAR</b>

CURRENTS			NEMA KVA CODE LETTER
NO LOAD	FULL LOAD	LOCKED ROTOR	
<b>4.7</b>	<b>12.3</b>	<b>81</b>	<b>H</b>

TORQUE				INERTIA			ACCEL TIME	
FULL LOAD lb-ft	LOCKED ROTOR %FLT	PULL UP %FLT	BREAK DOWN %FLT	ROTOR WR <sup>2</sup> lb-ft <sup>2</sup>	NEMA LOAD WK <sup>2</sup> lb-ft <sup>2</sup>	MAX ALLOWABLE WK <sup>2</sup> lb-ft <sup>2</sup>	NEMA LOAD WK <sup>2</sup> Sec	MAX ALLOWABLE WK <sup>2</sup> Sec
<b>29.75</b>	<b>240</b>	<b>145</b>	<b>260</b>	<b>0.986</b>	<b>39</b>	<b>186</b>	<b>3.42</b>	<b>16</b>

SAFE STALL TIME IN SECONDS		ALLOWABLE STARTS PER HOUR		SOUND PRESSURE LEVEL @ 3 FT dB(A)
COLD	HOT	COLD	HOT	
<b>39</b>	<b>27</b>	<b>2</b>	<b>1</b>	

APPROVED:	<b>D. Lu</b>	DRAWING NO.	<b>31057NP0104</b>	REVISION <b>0</b>
-----------	--------------	-------------	--------------------	-------------------

DATE:  
December 6, 2010

# CONNECTION DIAGRAM

CATALOG NO.:  
NP0104



**SCHEMATIC - Δ / Y CONNECTION**

## ACROSS THE LINE CONNECTION



**LINE**  
**230 VOLT CONNECTION**



**LINE**  
**460 VOLT CONNECTION**

**\*CONTACT TWMC IF YOU HAVE ANY QUESTIONS  
REGARDING THE MOTOR CONNECTION.**

**PH: 1-800-873-8326**