

DATE MARCH. 26, 2020	OUTLINE DIMENSIONS  3-PHASE INDUCTION MOTOR	MOTOR TYPE: AEHH8P
CAT. #: NP0202		FRAME NO. 256T

Pole	HP	kW	Hz	VOLT	r/min (rpm)
2	20	15	60	230/460	3600

Ins	Rating	Dimension in	Approx Weight	Bearings	
F	CONT.	inch	313 lbs	DE: 6309ZZ	NDE: 6307ZZ

Totally Enclosed Fan Cooled Squirrel Cage Rotor.

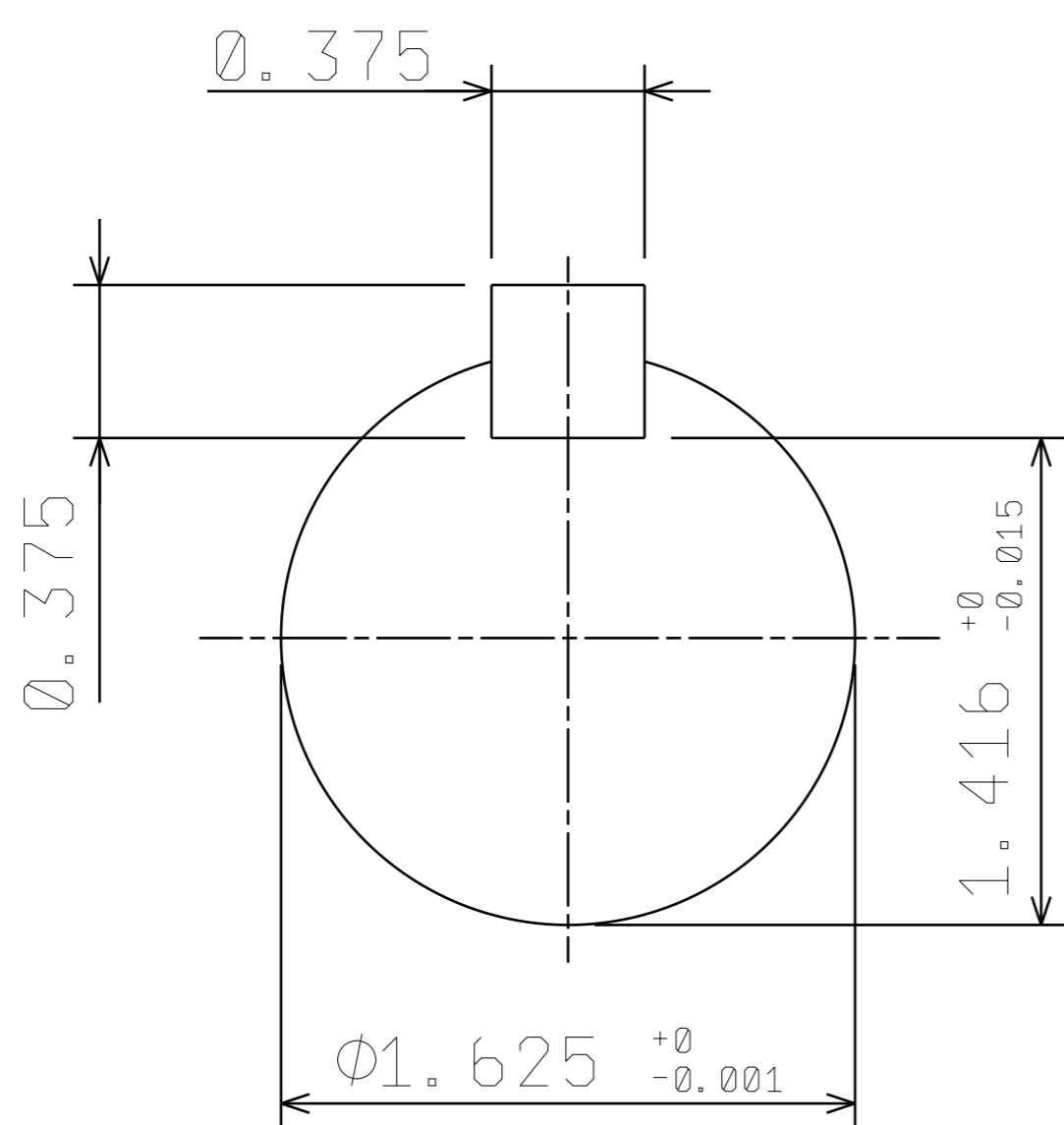
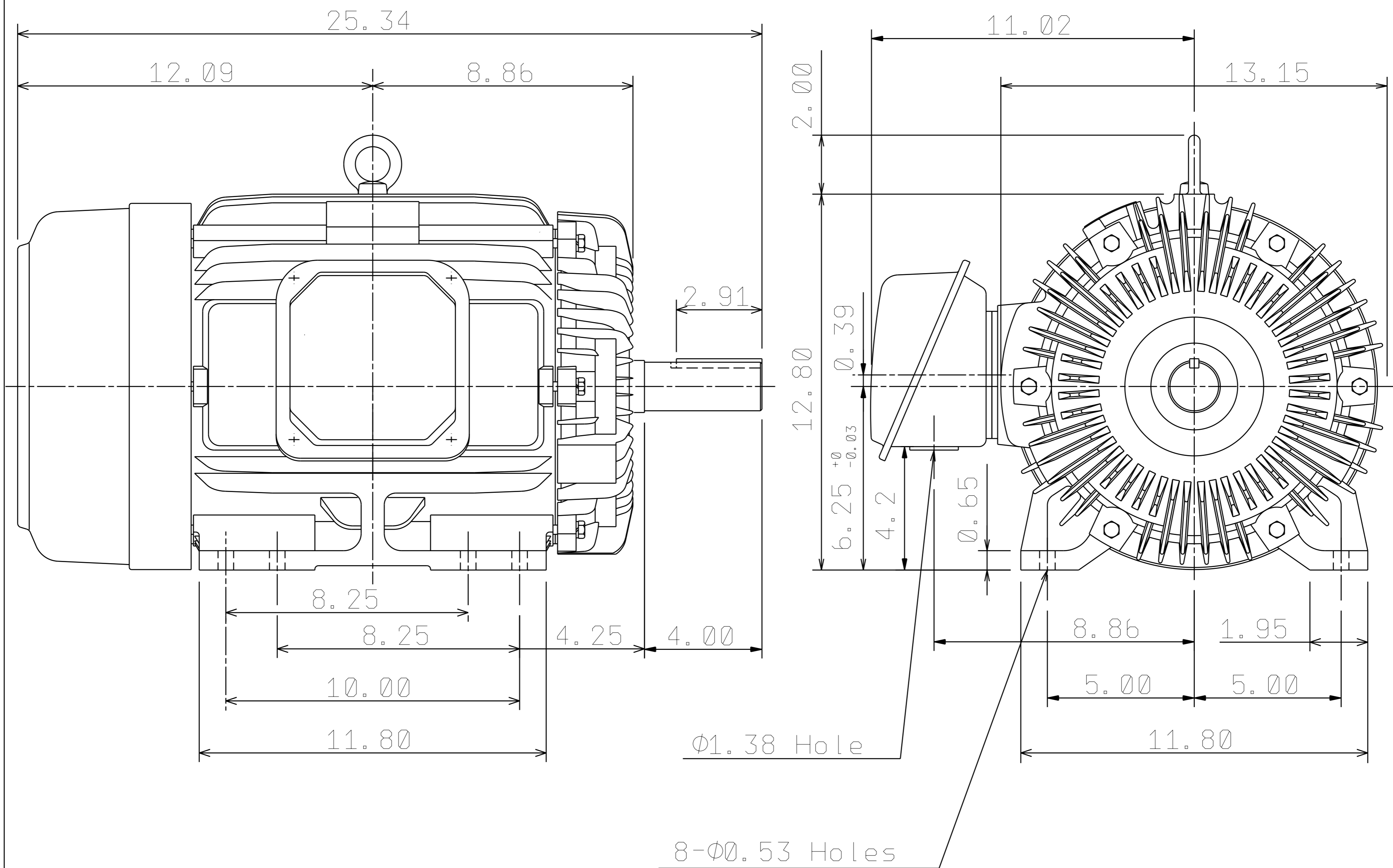

②	01.16.20	Enlarge T-BOX volume.	Z. L. LEE
---	----------	-----------------------	-----------

DWG.	H. C. YANG	06.27.19		DWG NO.
CHKD.	M. C. JENG	06.28.19		31057M089012
APPD.	M. C. JENG	06.28.19		

# TECO Westinghouse

ISSUED <b>8/29/2014</b>	<b>PERFORMANCE DATA</b> <b>3-PHASE INDUCTION MOTOR</b>	ENCLOSURE <b>TEFC</b>
TYPE <b>AEHH8P</b>		CATALOG# <b>NP0202</b>

### NAMEPLATE INFORMATION

OUTPUT		POLE	FRAME SIZE	VOLTAGE	HZ	RATED AMBIENT	INS. CLASS	NEMA DESIGN	TIME RATING	SERVICE FACTOR
HP	KW									
<b>20</b>	<b>14.9</b>	<b>2</b>	<b>256T</b>	<b>230/460</b>	<b>60</b>	<b>40°C</b>	<b>F</b>	<b>B</b>	<b>CONT.</b>	<b>1.15</b>

### VARIABLE FREQUENCY DRIVE SERVICE

VARIABLE TORQUE				OHMS/PHASE EQUIVALENT WYE CIRCUIT (AT RATED OPERATING TEMPERATURE 25°C)				
HZ	HP	RPM	TORQUE (lb-ft)	R1	R2	X1	X2	X <sub>m</sub>
<b>3~60</b>	<b>0.0025~20</b>	<b>180~3600</b>	<b>0.073~29.83</b>	<b>0.2419</b>	<b>0.3099</b>	<b>0.8788</b>	<b>1.4624</b>	<b>63.333</b>

CONSTANT TORQUE				CONSTANT HORSEPOWER			
HZ	HP	RPM	TORQUE (lb-ft)	HZ	HP	RPM	TORQUE (lb-ft)
<b>6~60</b>	<b>2~20</b>	<b>360~3600</b>	<b>29.83</b>	<b>60~90</b>	<b>20</b>	<b>3600~5400</b>	<b>29.83~19.89</b>

### TYPICAL PERFORMANCE

FULL LOAD RPM	EFFICIENCY				POWER FACTOR			SOUND PRESSURE LEVEL @ 3 FT Db(A)
	FULL LOAD		3/4 LOAD %	1/2 LOAD %	FULL LOAD %	3/4 LOAD %	1/2 LOAD %	
	MIN.%	NOM.%						
<b>3520</b>	<b>91</b>	<b>92.4</b>	<b>93</b>	<b>93.6</b>	<b>92.5</b>	<b>91.5</b>	<b>88</b>	<b>73</b>

CURRENTS									NEMA KVA CODE LETTER	SAFE STALL TIME IN SECONDS	
NO LOAD			FULL LOAD			LOCKED ROTOR				COLD	HOT
AT 208 VOLT	AT 230 VOLT	AT 460 VOLT	AT 208 VOLT	AT 230 VOLT	AT 460 VOLT	AT 208 VOLT	AT 230 VOLT	AT 460 VOLT			
<b>7.48</b>	<b>8.28</b>	<b>4.14</b>	<b>48.43</b>	<b>43.80</b>	<b>21.90</b>	<b>262.3</b>	<b>290.0</b>	<b>145</b>	<b>G</b>	<b>17</b>	<b>12</b>

TORQUE				INERTIA			ACCEL TIME (DOL)		ALLOWABLE STARTS PER HOUR	
FULL LOAD (lb-ft)	LOCKED ROTOR %FLT	PULL UP %FLT	BREAK DOWN %FLT	ROTOR WR <sup>2</sup> (lb-ft <sup>2</sup> )	NEMA LOAD WK <sup>2</sup> (lb-ft <sup>2</sup> )	MAX ALLOWABLE WK <sup>2</sup> (lb-ft <sup>2</sup> )	NEMA LOAD WK <sup>2</sup> Sec	MAX ALLOWABLE WK <sup>2</sup> Sec	COLD	HOT
<b>29.83</b>	<b>210</b>	<b>180</b>	<b>260</b>	<b>1.407</b>	<b>21</b>	<b>42</b>	<b>3.96</b>	<b>7.68</b>	<b>2</b>	<b>1</b>

APPROVED:	<b>M. PRATER</b>	DRAWING NO.	<b>31057NP0202</b>	REVISION:	<b>1</b>
-----------	------------------	-------------	--------------------	-----------	----------

DATE:  
December 6, 2010

# CONNECTION DIAGRAM

CATALOG NO.:  
NP0202



**SCHEMATIC - Δ / Y CONNECTION**

## ACROSS THE LINE CONNECTION



**LINE**  
**230 VOLT CONNECTION**



**LINE**  
**460 VOLT CONNECTION**

**\*CONTACT TWMC IF YOU HAVE ANY QUESTIONS  
REGARDING THE MOTOR CONNECTION.**

**PH: 1-800-873-8326**