

DATE
JAN. 15, 2015
CAT. #: NP0402G

OUTLINE DIMENSIONS
3-PHASE INDUCTION MOTOR

MOTOR TYPE:
AEHH8P-SGR
FRAME NO. 324TS

Pole	HP	kW	Hz	VOLT	Syn.Speed r/min(rpm)
2	40	29.8	60	230/460	3600

Ins	Rating	Dimension in	Approx Weight	Bearings	
F	CONT.	inch	596 lbs.	DE: 6312C3	NDE: 6212C3

Totally Enclosed Fan-Cooled Type. Squirrel-cage Rotor.

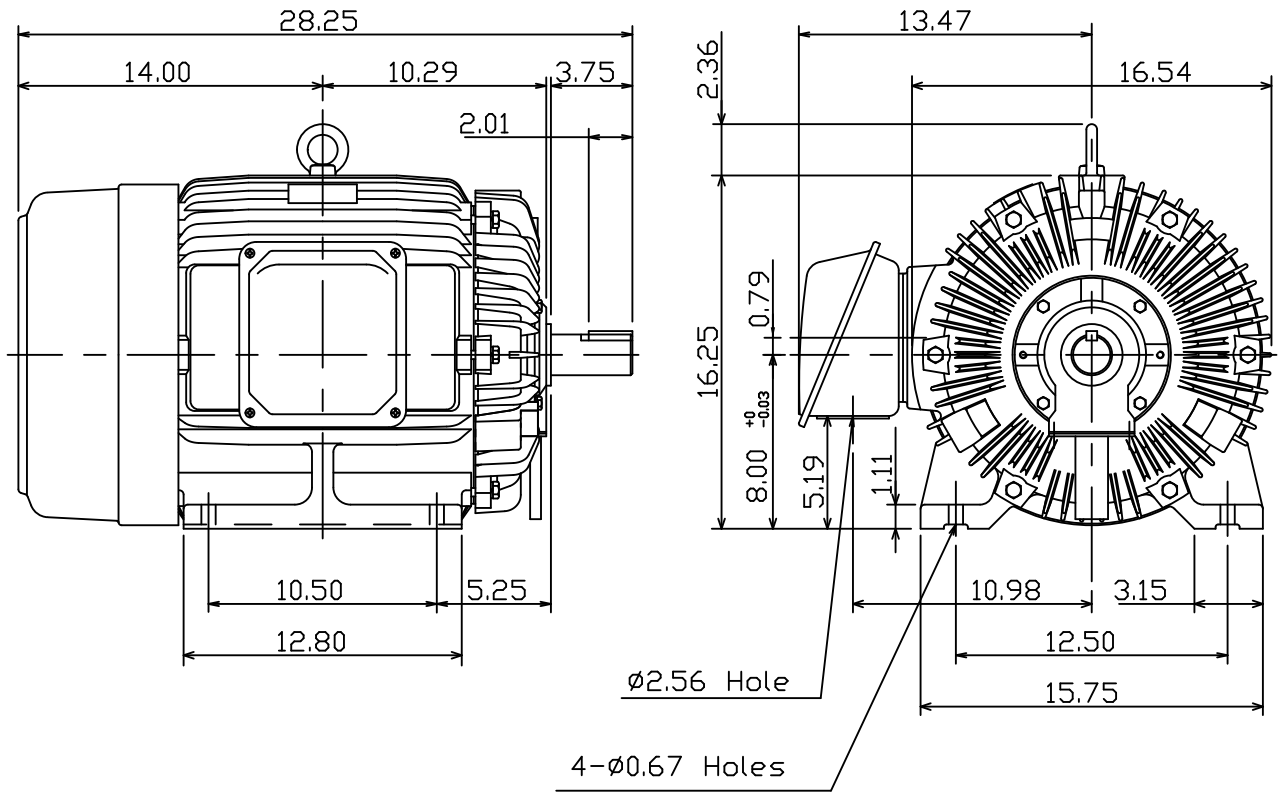

NOTE:
1. Shaft Grounding Ring Installed

12.06.10 郭耿良

DWN.	J.H.LIANG	05-20-99
CHKD.	C.H.KAO	06-15-99
APPD.	Y.B.HUANG	06-15-99



DWG NO.
31049J354013

TECO Westinghouse

ISSUED 1/26/2015	PERFORMANCE DATA 3-PHASE INDUCTION MOTOR	ENCLOSURE TEFC
TYPE AEHH8P-SGR		CATALOG# NP0402G

NAMEPLATE INFORMATION

OUTPUT		POLE	FRAME SIZE	VOLTAGE	HZ	RATED AMBIENT	INS. CLASS	NEMA DESIGN	TIME RATING	SERVICE FACTOR
HP	KW									
40	29.8	2	324TS	230/460	60	40°C	F	B	CONT.	1.15

VARIABLE FREQUENCY DRIVE SERVICE

VARIABLE TORQUE				OHMS/PHASE EQUIVALENT WYE CIRCUIT (AT RATED OPERATING TEMPERATURE 25°C)				
HZ	HP	RPM	TORQUE (lb-ft)	R1	R2	X1	X2	X _m
3~60	0.005~40	180~3600	0.146~59.16	0.0675	0.1122	0.4744	0.8272	28.406

CONSTANT TORQUE				CONSTANT HORSEPOWER			
HZ	HP	RPM	TORQUE (lb-ft)	HZ	HP	RPM	TORQUE (lb-ft)
6~60	4~40	360~3600	59.16	60~75	40	3600~4500	59.16~47.33

TYPICAL PERFORMANCE

FULL LOAD RPM	EFFICIENCY				POWER FACTOR			SOUND PRESSURE LEVEL @ 3 FT Db(A)
	FULL LOAD		3/4 LOAD %	1/2 LOAD %	FULL LOAD %	3/4 LOAD %	1/2 LOAD %	
	MIN.%	NOM.%						
3550	93	94.1	94.5	94.1	90	89	84.5	78

CURRENTS									NEMA KVA CODE LETTER	SAFE STALL TIME IN SECONDS	
NO LOAD			FULL LOAD			LOCKED ROTOR				COLD	HOT
AT 208 VOLT	AT 230 VOLT	AT 460 VOLT	AT 208 VOLT	AT 230 VOLT	AT 460 VOLT	AT 208 VOLT	AT 230 VOLT	AT 460 VOLT			
13.10	18.40	9.2	97.75	88.40	44.20	524.5	580.0	290	G	17	12

TORQUE				INERTIA			ACCEL TIME (DOL)		ALLOWABLE STARTS PER HOUR	
FULL LOAD (lb-ft)	LOCKED ROTOR %FLT	PULL UP %FLT	BREAK DOWN %FLT	ROTOR WR ² (lb-ft ²)	NEMA LOAD WK ² (lb-ft ²)	MAX ALLOWABLE WK ² (lb-ft ²)	NEMA LOAD WK ² Sec	MAX ALLOWABLE WK ² Sec	COLD	HOT
59.16	150	130	240	3.59	40	81	4.55	8.83	2	1

APPROVED:	M. PRATER	DRAWING NO.	31057NP0402G	REVISION:	1
-----------	------------------	-------------	---------------------	-----------	----------

DATE:
December 6, 2010

CONNECTION DIAGRAM

CATALOG NO.:
NP0402G

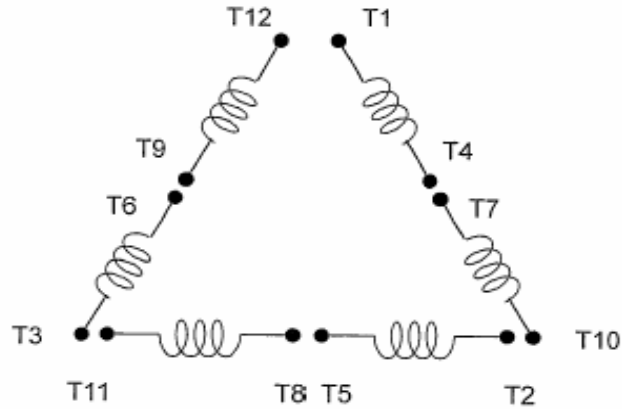

SCHEMATIC - Δ / Y CONNECTION

ACROSS THE LINE CONNECTION



**LINE
230 VOLT CONNECTION**



**LINE
460 VOLT CONNECTION**

***CONTACT TWMC IF YOU HAVE ANY QUESTIONS
REGARDING THE MOTOR CONNECTION.**

PH: 1-800-873-8326