

DATE MAY.26, 2020	OUTLINE DIMENSIONS 3-PHASE INDUCTION MOTOR	MOTOR TYPE: AEHH8P
CAT.#: NP0504		FRAME NO. 326T(X)

Pole	HP	kW	Hz	VOLT	r/min(rpm)
4	50	37	60	230/460	1800

Ins	Rating	Dimension in	Approx Weight	Bearings	
F	CONT.	inch	567 lbs	DE: 6312	NDE: 6310

Totally Enclosed Fan-Cooled Type. Squirrel-cage Rotor.

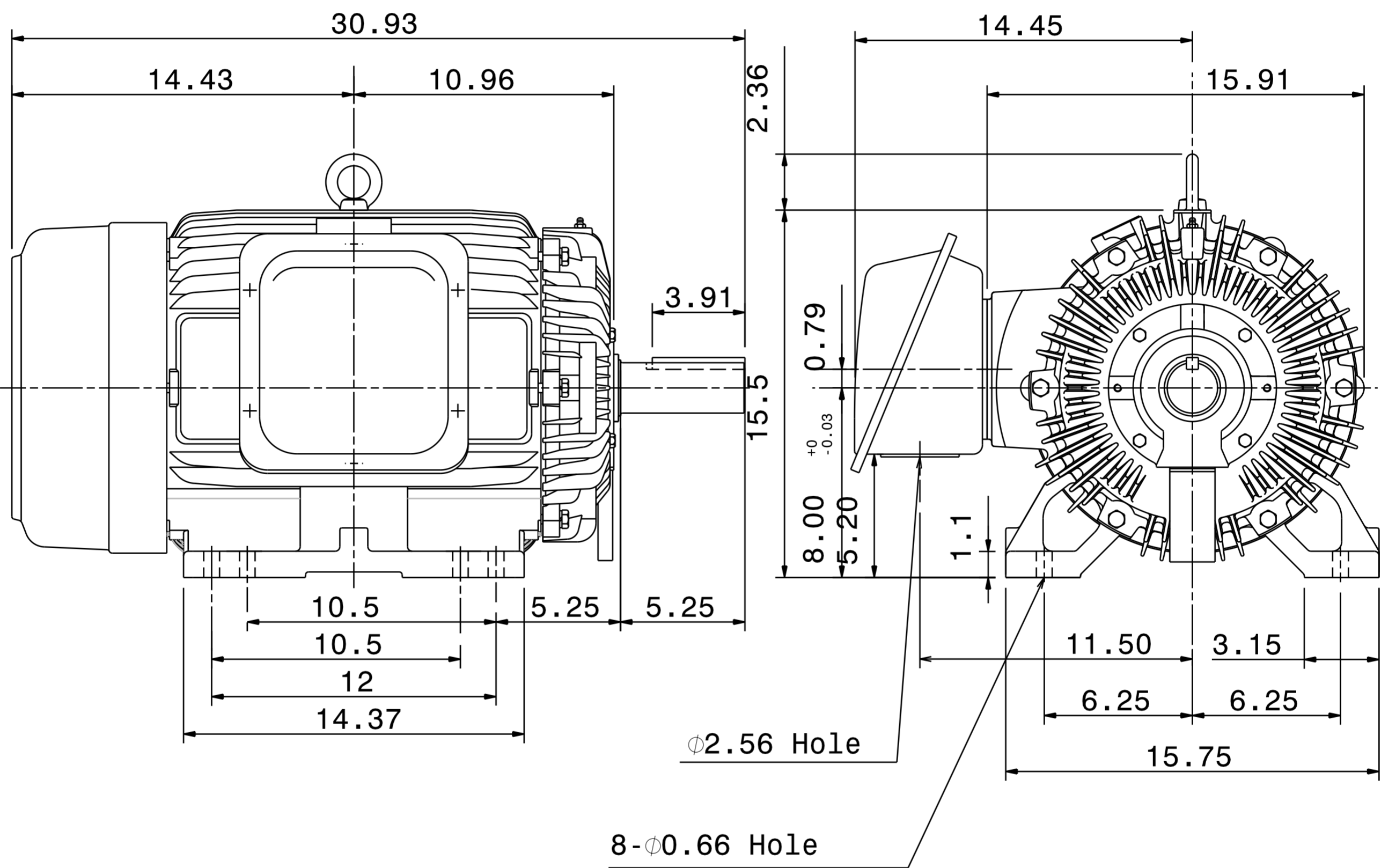

3	01.17.20	Enlarge T-BOX volume.	Z.L.LEE
---	----------	-----------------------	---------

DWG.	J.F.CHEN	06-27-19	TEC   Westinghouse	DWG NO.
CHKD.	M.C.JENG	06-28-19		31057M097013
APPD.	M.C.JENG	06-28-19		

TECO Westinghouse

ISSUED 07/23/19	PERFORMANCE DATA	ENCLOSURE TEFC
TYPE AEHH8P	3-PHASE INDUCTION MOTOR	CATALOG# NP0504

NAMEPLATE INFORMATION

OUTPUT		POLE	FRAME SIZE	VOLTAGE	HZ	RATED AMBIEN	INS. CLASS	NEMA DESIGN	TIME RATING	SERVICE FACTOR
HP	KW									
50	37.3	4	326T(X)	460	60	40°C	F	B	CONT.	1.15

TYPICAL PERFORMANCE

FULL LOAD RPM	EFFICIENCY				POWER FACTOR			MAXIMUM POWER FACTOR CORRECTION
	FULL LOAD		3/4 LOAD %	1/2 LOAD	F. L. %	3/4 LOAD	1/2 LOAD	
	NOM. %	MIN. %						
1770	94.5	93.6	94.5	94.0	85.0	83.0	77.0	8.26 KVAR

CURRENTS			NEMA KVA CODE LETTER
NO LOAD	FULL LOAD	LOCKED ROTOR	
18.3	58.3	363	G

TORQUE				INERTIA			ACCEL TIME	
FULL LOAD lb-ft	LOCKED ROTOR %FLT	PULL UP %FLT	BREAK DOWN %FLT	ROTOR WR ² lb-ft ²	NEMA LOAD WK ² lb-ft ²	MAX ALLOWABLE WK ² lb-ft ²	NEMA LOAD WK ² Sec	MAX ALLOWABLE WK ² Sec
148.31	230	200	250	6.393	39	596	0.81	11

SAFE STALL TIME IN SECONDS		ALLOWABLE STARTS PER HOUR		SOUND PRESSURE LEVEL @ 3 FT dB(A)
COLD	HOT	COLD	HOT	
17	12	2	1	

APPROVED:	D. Lu	DRAWING NO.	31057NP0504	REVISION 0
-----------	--------------	-------------	--------------------	-------------------

DATE:
December 6, 2010

CONNECTION DIAGRAM

CATALOG NO.:
NP0504



SCHEMATIC - Δ / Y CONNECTION

ACROSS THE LINE CONNECTION



LINE
230 VOLT CONNECTION



LINE
460 VOLT CONNECTION

***CONTACT TWMC IF YOU HAVE ANY QUESTIONS
REGARDING THE MOTOR CONNECTION.**

PH: 1-800-873-8326