

DATE
JAN. 15, 2015

CAT. #: NP0504G

OUTLINE DIMENSIONS

3-PHASE INDUCTION MOTOR

MOTOR TYPE:
AEHH8P-SGR

FRAME NO. 326T

| Pole | HP | kW | Hz | VOLT | Syn.Speed r/min(rpm) |
|------|----|------|----|---------|-------------------------|
| 4 | 50 | 37.3 | 60 | 230/460 | 1800 |

| Ins | Rating | Dimension in | Approx Weight | Bearings | |
|-----|--------|--------------|---------------|----------|-----------|
| F | CONT. | inch | 652 lbs. | DE: 6312 | NDE: 6212 |

Totally Enclosed Fan-Cooled Type. Squirrel-cage Rotor.

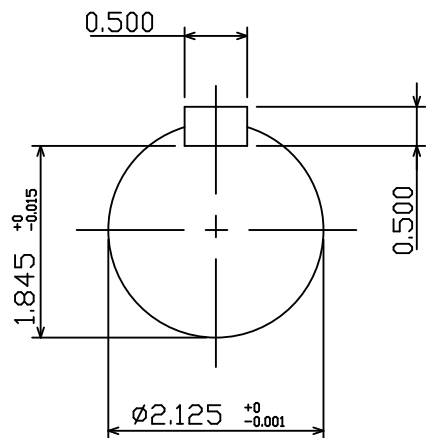
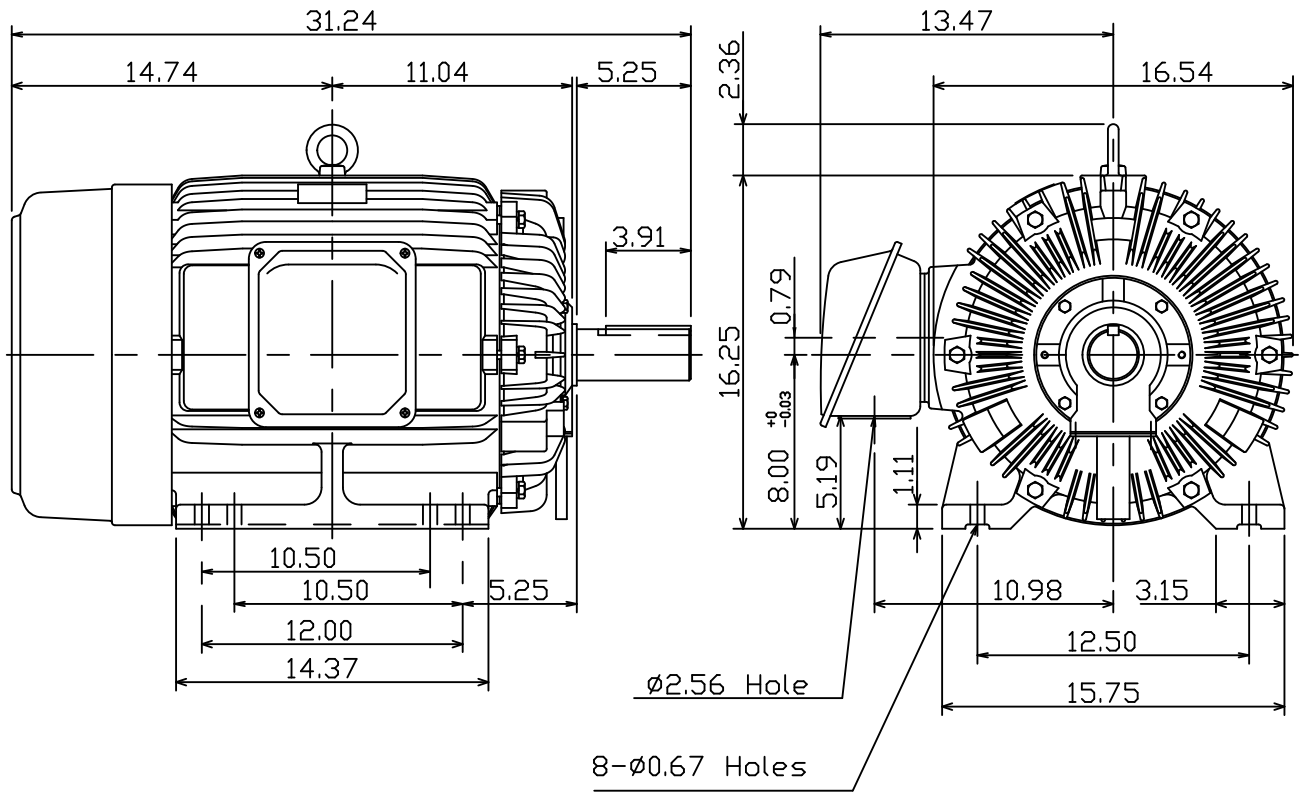

NOTE:
1. Shaft Grounding Ring Installed



| | | |
|-------|----------|----------|
| DWN. | K.L.KUD | 12 06 10 |
| CHKD. | K.L.KUD | 12 07 10 |
| APPD. | M.C.TSAI | 12 07 10 |



DWG NO.
31049J357380

TECO Westinghouse

| | | |
|----------------------------|---|----------------------------|
| ISSUED 1/26/2015 | PERFORMANCE DATA 3-PHASE INDUCTION MOTOR | ENCLOSURE TEFC |
| TYPE AEHH8P-SGR | | CATALOG# NP0504G |

NAMEPLATE INFORMATION

| OUTPUT HP | KW | POLE | FRAME SIZE | VOLTAGE | HZ | RATED AMBIENT | INS. CLASS | NEMA DESIGN | TIME RATING | SERVICE FACTOR |
|--------------|-------------|----------|---------------|----------------|-----------|------------------|---------------|----------------|----------------|-------------------|
| 50 | 37.3 | 4 | 326T | 230/460 | 60 | 40°C | F | B | CONT. | 1.15 |

VARIABLE FREQUENCY DRIVE SERVICE

| VARIABLE TORQUE | | | | OHMS/PHASE EQUIVALENT WYE CIRCUIT (AT RATED OPERATING TEMPERATURE 25°C) | | | | |
|-----------------|------------------|----------------|--------------------|--|---------------|---------------|---------------|----------------|
| HZ | HP | RPM | TORQUE (lb-ft) | R1 | R2 | X1 | X2 | X _m |
| 3~60 | 0.0063~50 | 90~1800 | 0.368~148.3 | 0.0632 | 0.1436 | 0.3803 | 0.8707 | 18.415 |

| CONSTANT TORQUE | | | | CONSTANT HORSEPOWER | | | |
|-----------------|-------------|-----------------|-------------------|---------------------|-----------|------------------|--------------------|
| HZ | HP | RPM | TORQUE (lb-ft) | HZ | HP | RPM | TORQUE (lb-ft) |
| 6~60 | 5~50 | 180~1800 | 148.3 | 60~90 | 50 | 1800~2700 | 148.3~98.87 |

TYPICAL PERFORMANCE

| FULL LOAD RPM | EFFICIENCY | | | | POWER FACTOR | | | SOUND PRESSURE LEVEL @ 3 FT Db(A) |
|---------------------|-------------|-------------|---------------|---------------|----------------|---------------|---------------|--|
| | FULL LOAD | | 3/4 LOAD % | 1/2 LOAD % | FULL LOAD % | 3/4 LOAD % | 1/2 LOAD % | |
| | MIN.% | NOM.% | | | | | | |
| 1770 | 93.6 | 94.5 | 95 | 95 | 87 | 86 | 80.5 | 76 |

| CURRENTS | | | | | | | | | NEMA KVA CODE LETTER | SAFE STALL TIME IN SECONDS | |
|-------------------|-------------------|-------------------|-------------------|-------------------|-------------------|-------------------|-------------------|-------------------|-------------------------------|----------------------------------|-----------|
| NO LOAD | | | FULL LOAD | | | LOCKED ROTOR | | | | COLD | HOT |
| AT 208 VOLT | AT 230 VOLT | AT 460 VOLT | AT 208 VOLT | AT 230 VOLT | AT 460 VOLT | AT 208 VOLT | AT 230 VOLT | AT 460 VOLT | | | |
| 23.20 | 26.20 | 13.1 | 125.84 | 113.80 | 56.90 | 656.6 | 726.0 | 363 | G | 17 | 12 |

| TORQUE | | | | INERTIA | | | ACCEL TIME (DOL) | | ALLOWABLE STARTS PER HOUR | |
|-------------------------|-------------------------|--------------------|-----------------------|---|--|--|--|--|---------------------------------|----------|
| FULL LOAD (lb-ft) | LOCKED ROTOR %FLT | PULL UP %FLT | BREAK DOWN %FLT | ROTOR WR ² (lb-ft ²) | NEMA LOAD WK ² (lb-ft ²) | MAX ALLOWABLE WK ² (lb-ft ²) | NEMA LOAD WK ² Sec | MAX ALLOWABLE WK ² Sec | COLD | HOT |
| 148.30 | 210 | 170 | 220 | 10.123 | 232 | 427 | 4.77 | 8.61 | 2 | 1 |

| | | | | | |
|-----------|------------------|-------------|---------------------|-----------|----------|
| APPROVED: | M. PRATER | DRAWING NO. | 31057NP0504G | REVISION: | 1 |
|-----------|------------------|-------------|---------------------|-----------|----------|

DATE:
December 6, 2010

CONNECTION DIAGRAM

CATALOG NO.:
NP0504G



SCHEMATIC - Δ / Y CONNECTION

ACROSS THE LINE CONNECTION



LINE
230 VOLT CONNECTION



LINE
460 VOLT CONNECTION

***CONTACT TWMC IF YOU HAVE ANY QUESTIONS
REGARDING THE MOTOR CONNECTION.**

PH: 1-800-873-8326