

TYPE	OUTPUT		POLE	TIME RATING	VOLTAGE	Hz	SYN. SPEED R.P.M
	HP.	KW.					
AEHH8P	100	74.6	6	CONT.	230/460	60	1200

TOTALLY ENCLOSED FAN-COOLED TYPE, SQUIRREL-CAGE ROTOR

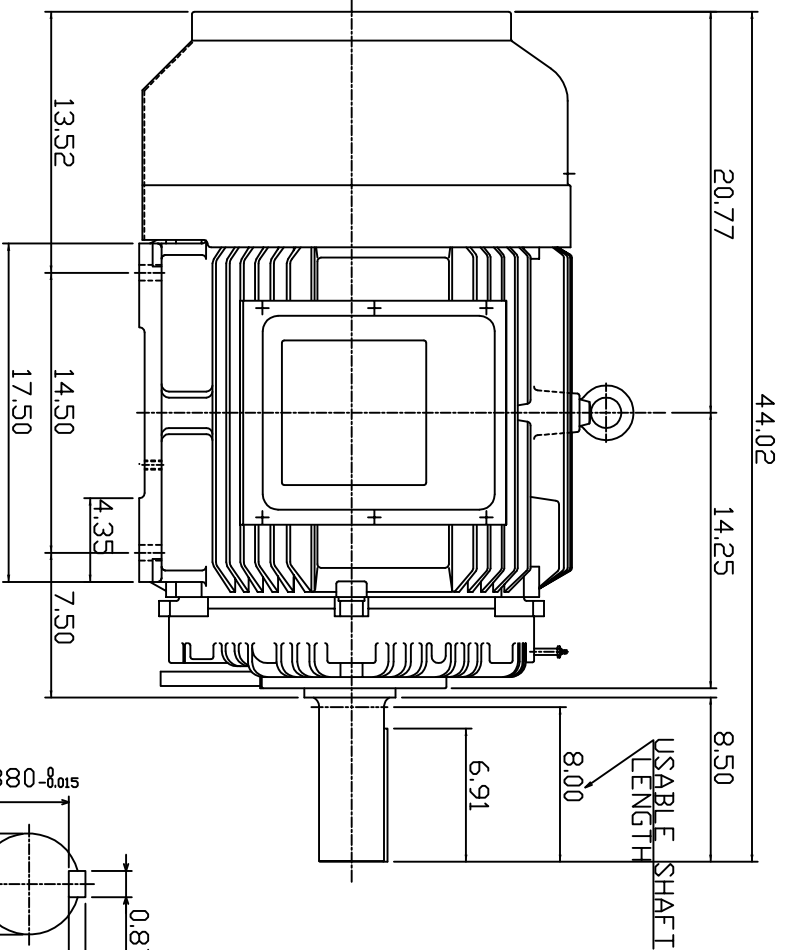
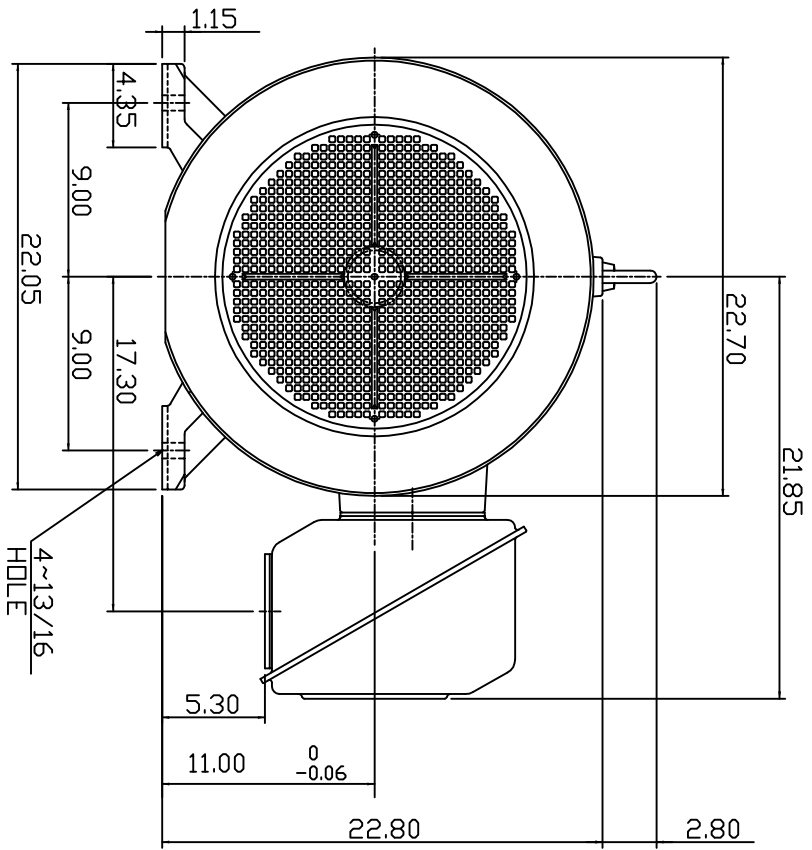

SHAFT END
[ENLARGED VIEW]

$\phi 3.375_{-0.001}$



- NOTE:
1. DIMENSIONS IN INCHES
 2. FRAME SIZE 444T
 3. F CLASS INSULATION, S.F. 1.15
 4. FOR BELTED APPLICATION
 5. BEARING NO.: DRIVE END: NU318C3
OPP. DRIVE END: 6316C3
 6. ENCLDURE: IP44
 7. APPRDX. WEIGHT: 1580 LBS

DWN.	SLEE	JAN. 26 '2011
CHKD.	SLEE	JAN. 26 '2011
APPD.	H.LIU	JAN. 26 '2011

DATE FEB. 11, 2011

CATALOG # NP1006R

OUTLINE DIMENSIONS
3-PHASE INDUCTION MOTOR

TECCO Westinghouse

DWG NO. 3A049DWB10464-25
REV: 00

TECO Westinghouse

ISSUED 8/29/2014	PERFORMANCE DATA 3-PHASE INDUCTION MOTOR	ENCLOSURE TEFC
TYPE AEHH8P		CATALOG# NP1006R

NAMEPLATE INFORMATION

OUTPUT		POLE	FRAME SIZE	VOLTAGE	HZ	RATED AMBIENT	INS. CLASS	NEMA DESIGN	TIME RATING	SERVICE FACTOR
HP	KW									
100	74.6	6	444T	230/460	60	40°C	F	B	CONT.	1.15

VARIABLE FREQUENCY DRIVE SERVICE

VARIABLE TORQUE				OHMS/PHASE EQUIVALENT WYE CIRCUIT (AT RATED OPERATING TEMPERATURE 25°C)				
HZ	HP	RPM	TORQUE (lb-ft)	R1	R2	X1	X2	X _m
3~60	0.0125~100	60~1200	1.09~444	0.0778	0.0497	0.5102	0.978	16.2

CONSTANT TORQUE				CONSTANT HORSEPOWER			
HZ	HP	RPM	TORQUE (lb-ft)	HZ	HP	RPM	TORQUE (lb-ft)
6~60	10~100	118~1200	444	60~90	100	1200-1800	444~296

TYPICAL PERFORMANCE

FULL LOAD RPM	EFFICIENCY				POWER FACTOR			SOUND PRESSURE LEVEL @ 3 FT Db(A)
	FULL LOAD		3/4 LOAD %	1/2 LOAD %	FULL LOAD %	3/4 LOAD %	1/2 LOAD %	
	MIN.%	NOM.%						
1182	94.1	95	94.5	93.6	82.5	80	73	77

CURRENTS										NEMA KVA CODE LETTER	SAFE STALL TIME IN SECONDS	
NO LOAD			FULL LOAD			LOCKED ROTOR					COLD	HOT
AT 208 VOLT	AT 230 VOLT	AT 460 VOLT	AT 208 VOLT	AT 230 VOLT	AT 460 VOLT	AT 208 VOLT	AT 230 VOLT	AT 460 VOLT				
79.70	96.00	48	263.17	238.00	119.00	1311.3	1450.0	725	G	21	15	

TORQUE				INERTIA			ACCEL TIME (DOL)		ALLOWABLE STARTS PER HOUR	
FULL LOAD (lb-ft)	LOCKED ROTOR %FLT	PULL UP %FLT	BREAK DOWN %FLT	ROTOR WR ² (lb-ft ²)	NEMA LOAD WK ² (lb-ft ²)	MAX ALLOWABLE WK ² (lb-ft ²)	NEMA LOAD WK ² Sec	MAX ALLOWABLE WK ² Sec	COLD	HOT
444.00	140	110	230	56	1181	2953	6.00	14.58	2	1

APPROVED:	M. PRATER	DRAWING NO.	31057NP1006	REVISION:	1
-----------	------------------	-------------	--------------------	-----------	----------

DATE:
December 6, 2010

CONNECTION DIAGRAM

CATALOG NO.:
NP1006R



SCHEMATIC - Δ / Y CONNECTION

ACROSS THE LINE CONNECTION



LINE
230 VOLT CONNECTION



LINE
460 VOLT CONNECTION

***CONTACT TWMC IF YOU HAVE ANY QUESTIONS REGARDING THE MOTOR CONNECTION.**

PH: 1-800-873-8326