

TYPE	OUTPUT		POLE	TIME RATING	VOLTAGE V	Hz	SYN SPEED R.P.M
	HP.	KW.					
AEHH8P	125	93.3	4	CONT.	230/460	60	1800

TOTALLY ENCLOSED FAN-COOLED TYPE, SQUIRREL-CAGE ROTOR

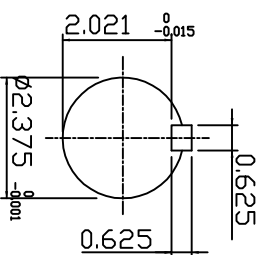
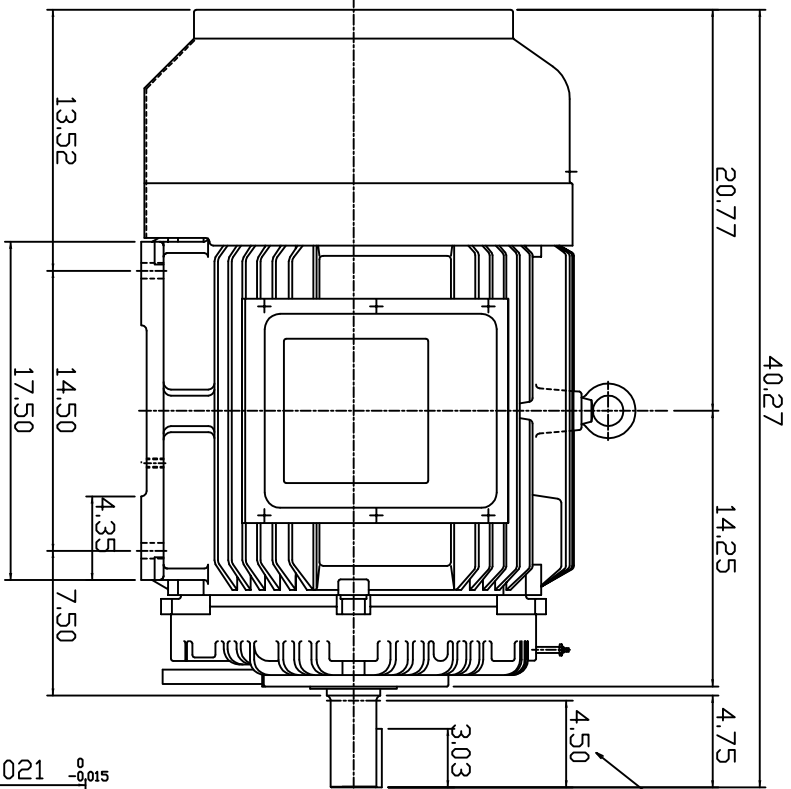
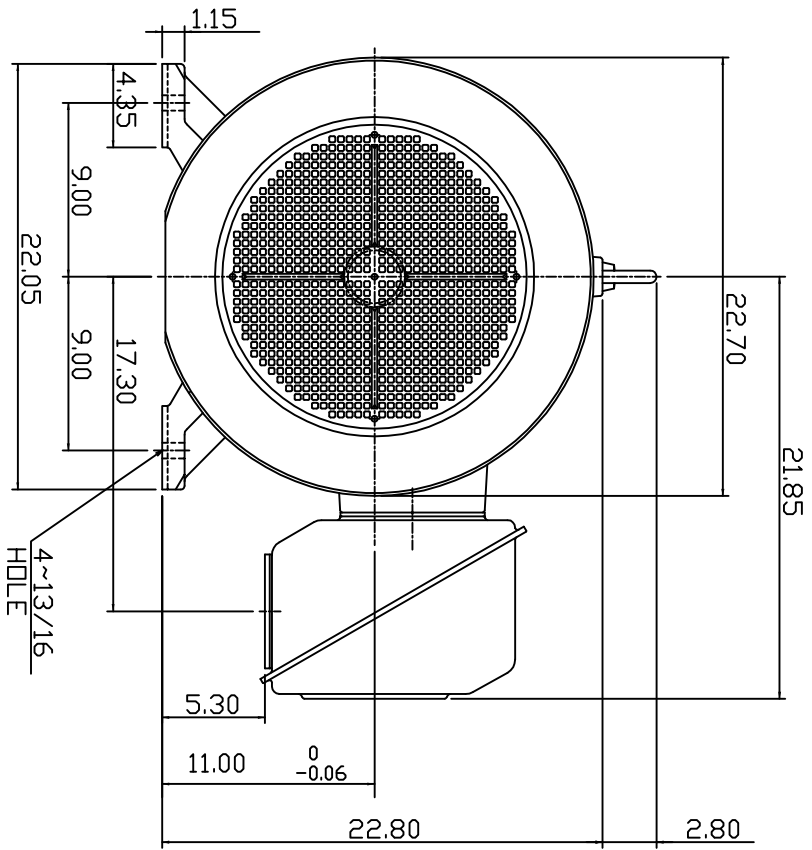

SHAFT END
[ENLARGED VIEW]

NOTE:

1. DIMENSIONS IN INCHES
2. FRAME SIZE 444TS
3. F CLASS INSULATION, S.F. 1.15
4. FOR DIRECT FLEXIBLE COUPLING
5. BEARING NO.: DRIVE END: 6318C3
DPP, DRIVE END: 6316C3
6. ENCLOSURE: IP44
7. APPRDX. WEIGHT: 1500 LBS

DATE	DWN.	SLEE	JAN. 26 '2011
FEB. 11, 2011	CHKD.	SLEE	JAN. 26 '2011
CATALOG #:	APPD.	H.LIU	JAN. 26 '2011

DATE: FEB. 11, 2011
 CATALOG #: NP1254S
TECCO Westinghouse
 OUTLINE DIMENSIONS
 3-PHASE INDUCTION MOTOR
 DWG NO. 3A049DWB10464-21
 REV: 00

6 5 4 3 2 1

TECO Westinghouse

ISSUED 8/29/2014	PERFORMANCE DATA 3-PHASE INDUCTION MOTOR	ENCLOSURE TEFC
TYPE AEHH8P		CATALOG# NP1254S

NAMEPLATE INFORMATION

OUTPUT		POLE	FRAME SIZE	VOLTAGE	HZ	RATED AMBIENT	INS. CLASS	NEMA DESIGN	TIME RATING	SERVICE FACTOR
HP	KW									
125	93.3	4	444TS	230/460	60	40°C	F	B	CONT.	1.15

VARIABLE FREQUENCY DRIVE SERVICE

VARIABLE TORQUE				OHMS/PHASE EQUIVALENT WYE CIRCUIT (AT RATED OPERATING TEMPERATURE 25°C)				
HZ	HP	RPM	TORQUE (lb-ft)	R1	R2	X1	X2	X _m
3~60	0.0156~125	90~1800	0.91~368	0.0454	0.0373	0.3807	0.683	15.6

CONSTANT TORQUE				CONSTANT HORSEPOWER			
HZ	HP	RPM	TORQUE (lb-ft)	HZ	HP	RPM	TORQUE (lb-ft)
6~60	12.5~125	180~1800	368	60~90	125	1800-2700	368~245.33

TYPICAL PERFORMANCE

FULL LOAD RPM	EFFICIENCY				POWER FACTOR			SOUND PRESSURE LEVEL @ 3 FT Db(A)
	FULL LOAD		3/4 LOAD %	1/2 LOAD %	FULL LOAD %	3/4 LOAD %	1/2 LOAD %	
	MIN.%	NOM.%						
1780	94.5	95.4	95	94.1	85	83	77	81

CURRENTS									NEMA KVA CODE LETTER	SAFE STALL TIME IN SECONDS	
NO LOAD			FULL LOAD			LOCKED ROTOR				COLD	HOT
AT 208 VOLT	AT 230 VOLT	AT 460 VOLT	AT 208 VOLT	AT 230 VOLT	AT 460 VOLT	AT 208 VOLT	AT 230 VOLT	AT 460 VOLT			
67.50	75.80	37.9	319.00	292.00	144.00	1641.4	1815.0	910	G	24	17

TORQUE				INERTIA			ACCEL TIME (DOL)		ALLOWABLE STARTS PER HOUR	
FULL LOAD (lb-ft)	LOCKED ROTOR %FLT	PULL UP %FLT	BREAK DOWN %FLT	ROTOR WR ² (lb-ft ²)	NEMA LOAD WK ² (lb-ft ²)	MAX ALLOWABLE WK ² (lb-ft ²)	NEMA LOAD WK ² Sec	MAX ALLOWABLE WK ² Sec	COLD	HOT
368.70	130	100	220	44.3	542	1084	5.41	10.40	2	1

APPROVED:	M. PRATER	DRAWING NO.	31057NP1254	REVISION:	1
-----------	------------------	-------------	--------------------	-----------	----------

DATE:
June 1, 2011

CONNECTION DIAGRAM

CATALOG NO.:
NP1254S



SCHEMATIC - Δ / Y CONNECTION

ACROSS THE LINE CONNECTION



LINE
230 VOLT CONNECTION



LINE
460 VOLT CONNECTION

***CONTACT TWMC IF YOU HAVE ANY QUESTIONS
REGARDING THE MOTOR CONNECTION.**

PH: 1-800-873-8326