

11

10

9

8

7

6

5

4

3

2

1

POLE	HP	kW	Hz	VOLT	r/min(RPM)	INS	RATING	DIMENSION IN	APPROX WEIGHT	BEARINGS
2	150	111	60	460	3600	F	CONT.	INCHES	1481 lbs	DE: 6314C3 NDE: 6314C3

TOTALLY ENCLOSED FAN-COOLED TYPE. SQUIRREL-CAGE ROTOR

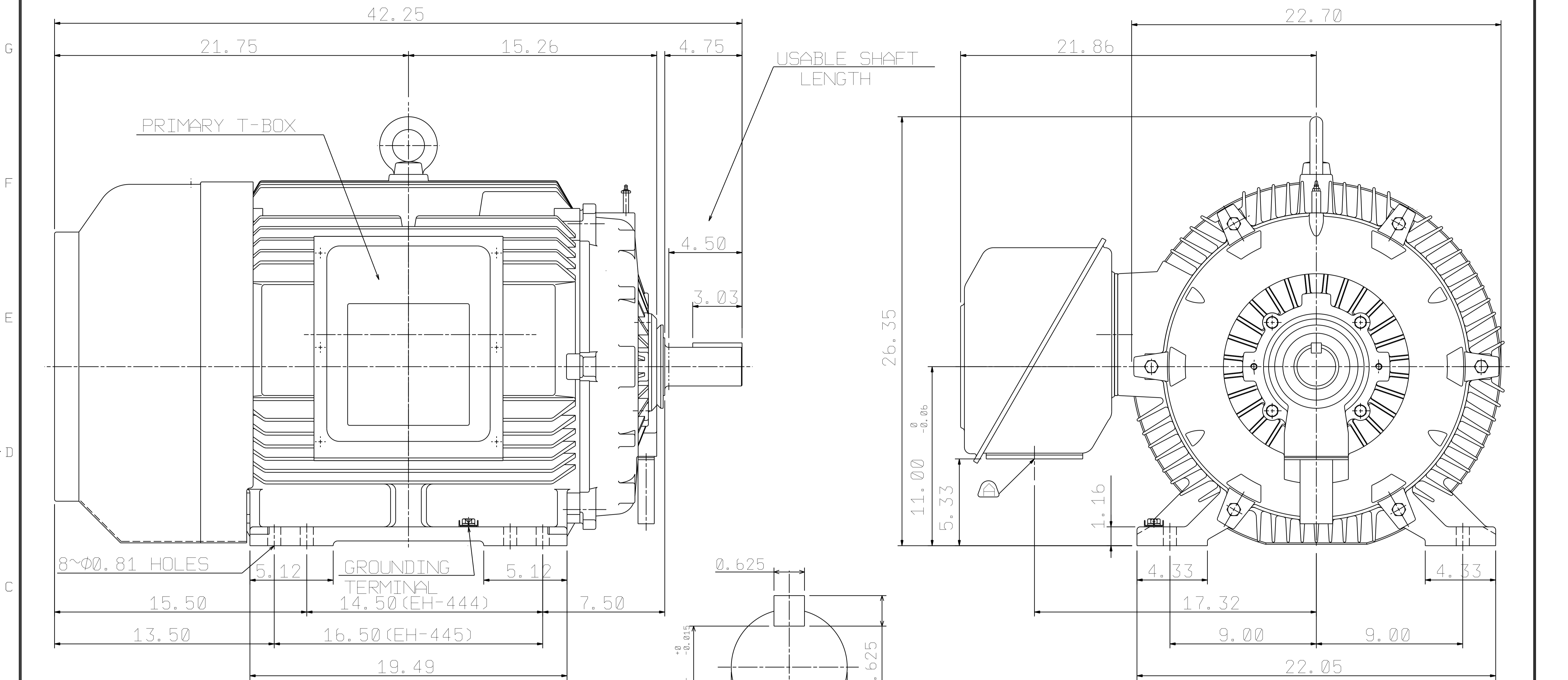

NOTE:

- FOR DIRECT FLEXIBLE COUPLING
- ENCLOSURE: IP54 PROTECTION

REMOVABLE COVER FOR CABLE ENTRY TO BE DRILLED BY THE CUSTOMER.

OUTLINE DIMENSIONS
3-PHASE INDUCTION MOTOR

MOTOR TYPE	AEHH8P	FRAME NO.	445TS
CATALOG #	NP1502	DATE	MARCH, 5, 2020
ORDER NO.		TRANS. SHEET	

TEC Westinghouse

DWG NO.
31057C524081

1	06.13.19	Show approx weight	K.L.KUO
APPD.	BEN. YANG	04.08.19	
CHKD.	K.L.KUO	04.08.19	
DWG.	K.L.KUO	02.12.19	

11

10

9

8

7

6

5

4

3

2

1

TECO Westinghouse

ISSUED 8/29/2014	PERFORMANCE DATA 3-PHASE INDUCTION MOTOR	ENCLOSURE TEFC
TYPE AEHH8P		CATALOG# NP1502

NAMEPLATE INFORMATION

OUTPUT		POLE	FRAME SIZE	VOLTAGE	HZ	RATED AMBIENT	INS. CLASS	NEMA DESIGN	TIME RATING	SERVICE FACTOR
HP	KW									
150	111.9	2	445TS	460	60	40°C	F	B	CONT.	1.15

VARIABLE FREQUENCY DRIVE SERVICE

VARIABLE TORQUE				OHMS/PHASE EQUIVALENT WYE CIRCUIT (AT RATED OPERATING TEMPERATURE 25°C)				
HZ	HP	RPM	TORQUE (lb-ft)	R1	R2	X1	X2	X _m
3~60	0.0188~150	180~3600	0.548~220	0.0362	0.029	0.306	0.567	15.5

CONSTANT TORQUE				CONSTANT HORSEPOWER			
HZ	HP	RPM	TORQUE (lb-ft)	HZ	HP	RPM	TORQUE (lb-ft)
6~60	15~150	360~3600	220	60	150	3600	220

TYPICAL PERFORMANCE

FULL LOAD RPM	EFFICIENCY				POWER FACTOR			SOUND PRESSURE LEVEL @ 3 FT Db(A)
	FULL LOAD		3/4 LOAD %	1/2 LOAD %	FULL LOAD %	3/4 LOAD %	1/2 LOAD %	
	MIN.%	NOM.%						
3566	94.1	95	94.5	93.6	87	84.5	81	83

NO LOAD			FULL LOAD		LOCKED ROTOR		NEMA KVA CODE LETTER	SAFE STALL TIME IN SECONDS	
AT 460 VOLT			AT 460 VOLT		AT 460 VOLT			COLD	HOT
42			170.00		1085		G	28	19

TORQUE				INERTIA			ACCEL TIME (DOL)		ALLOWABLE STARTS PER HOUR	
FULL LOAD (lb-ft)	LOCKED ROTOR %FLT	PULL UP %FLT	BREAK DOWN %FLT	ROTOR WR ² (lb-ft ²)	NEMA LOAD WK ² (lb-ft ²)	MAX ALLOWABLE WK ² (lb-ft ²)	NEMA LOAD WK ² Sec	MAX ALLOWABLE WK ² Sec	COLD	HOT
220.00	110	88	220	20	133	133	4.93	4.93	2	1

APPROVED:	M. PRATER	DRAWING NO.	31057NP1502	REVISION:	1
-----------	------------------	-------------	--------------------	-----------	----------

DATE:
December 6, 2010

CONNECTION DIAGRAM

CATALOG NO.:
NP1502

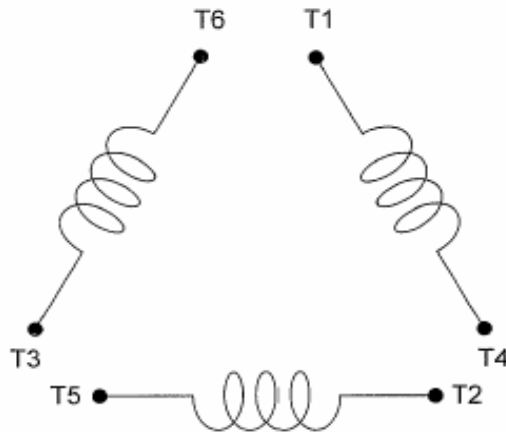

SCHEMATIC - Δ / Y CONNECTION

ACROSS THE LINE CONNECTION

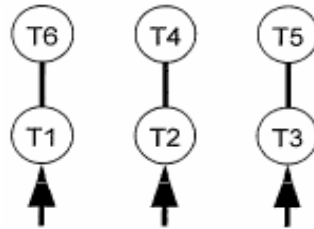

460 VOLT CONNECTION

***CONTACT TWMC IF YOU HAVE ANY QUESTIONS
REGARDING THE MOTOR CONNECTION.**

PH: 1-800-873-8326