

11 10 9 8 7 6 5 4 3 2 1

TYPE	OUTPUT		POLE	TIME RATING	VOLTAGE V	Hz	SYN.SPEED R.P.M
	HP.	KW.					
AEHH8P	150	112	4	CONT.	460	60	1800

TOTALLY ENCLOSED FAN-COOLED TYPE, SQUIRREL-CAGE ROTOR

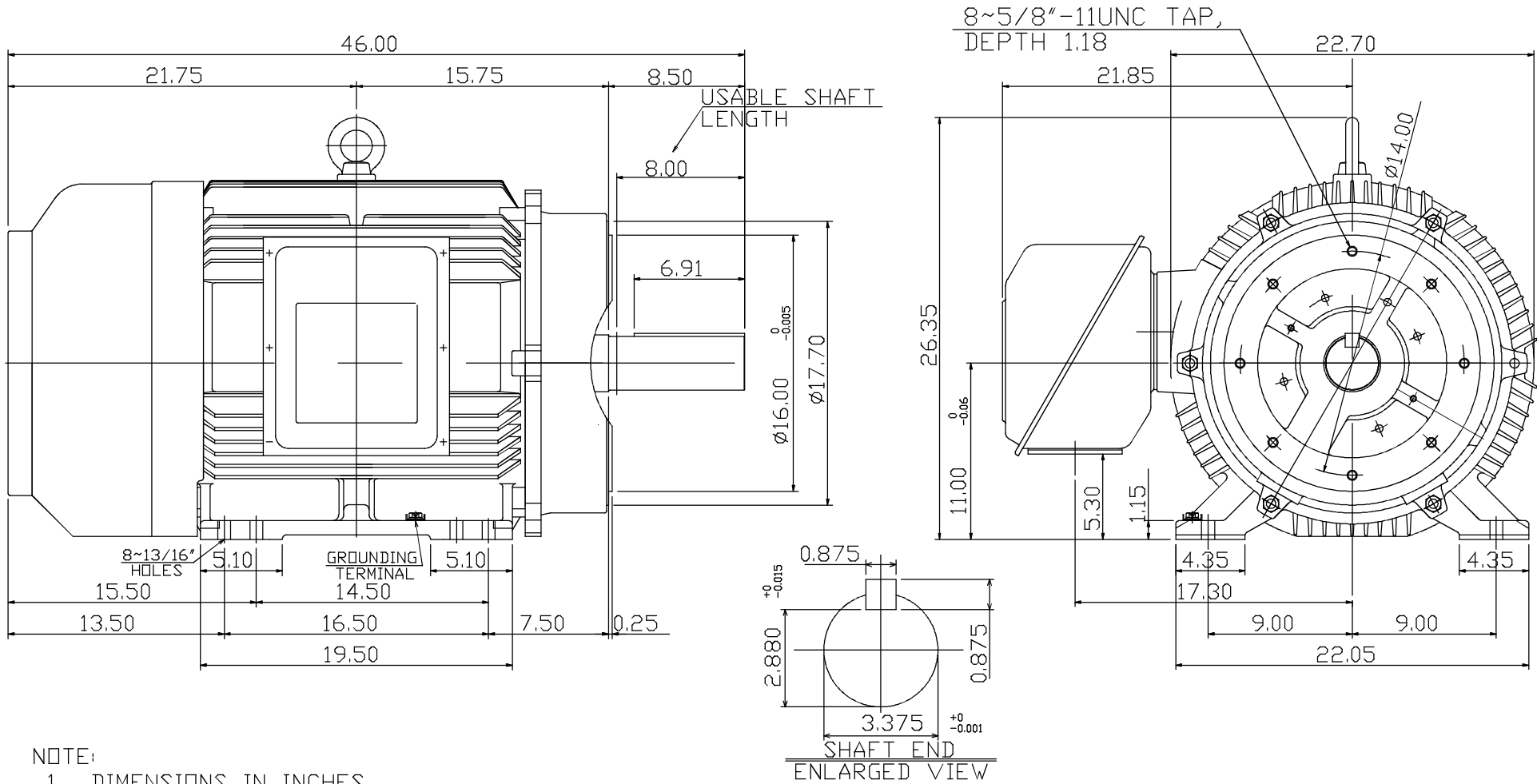

- NOTE:
1. DIMENSIONS IN INCHES
 2. FRAME SIZE 445TC
 3. F CLASS INSULATION, S.F. 1.15
 4. FOR DIRECT FLEXIBLE COUPLING
 5. BEARING NO.: DRIVE END: 6318C3
OPP. DRIVE END: 6316C3
 6. ENCLOSURE: IP44
 7. APPROX. WEIGHT: 1700 LBS

DATE	JAN. 6, 2012	OUTLINE DIMENSIONS
CATALOG #:	NP1504C	
TECO Westinghouse		DWG NO. REV: 01
		3A049DWB10464-26

DWN.	S.LEE	JAN•26•2011
CHKD.	S.LEE	JAN•26•2011
APPD.	H.LIU	JAN•26•2011

11 10 9 8 7 6 5 4 3 2 1

TECO Westinghouse

ISSUED 8/29/2014	PERFORMANCE DATA 3-PHASE INDUCTION MOTOR	ENCLOSURE TEFC
TYPE AEHH8PCF		CATALOG# NP1504C

NAMEPLATE INFORMATION

OUTPUT		POLE	FRAME SIZE	VOLTAGE	HZ	RATED AMBIENT	INS. CLASS	NEMA DESIGN	TIME RATING	SERVICE FACTOR
HP	KW									
150	112	4	445TC	460	60	40°C	F	B	CONT.	1.15

VARIABLE FREQUENCY DRIVE SERVICE

VARIABLE TORQUE				OHMS/PHASE EQUIVALENT WYE CIRCUIT (AT RATED OPERATING TEMPERATURE 25°C)				
HZ	HP	RPM	TORQUE (lb-ft)	R1	R2	X1	X2	X _m
3~60	0.0188~150	90~1800	1.10~442	0.0492	0.038	0.367	0.691	11.3

CONSTANT TORQUE				CONSTANT HORSEPOWER			
HZ	HP	RPM	TORQUE (lb-ft)	HZ	HP	RPM	TORQUE (lb-ft)
6~60	15~150	180~1800	442	60~90	150	1800~2700	442~294.66

TYPICAL PERFORMANCE

FULL LOAD RPM	EFFICIENCY				POWER FACTOR			SOUND PRESSURE LEVEL @ 3 FT Db(A)
	FULL LOAD		3/4 LOAD %	1/2 LOAD %	FULL LOAD %	3/4 LOAD %	1/2 LOAD %	
	MIN.%	NOM.%						
1783	95	95.8	95.4	94.5	85	83	78	81

CURRENTS			NEMA KVA CODE LETTER	SAFE STALL TIME IN SECONDS	
NO LOAD	FULL LOAD	LOCKED ROTOR		COLD	HOT
AT 460 VOLT	AT 460 VOLT	AT 460 VOLT			
46.6	172.00	1085	G	25	17

TORQUE				INERTIA			ACCEL TIME (DOL)		ALLOWABLE STARTS PER HOUR	
FULL LOAD (lb-ft)	LOCKED ROTOR %FLT	PULL UP %FLT	BREAK DOWN %FLT	ROTOR WR ² (lb-ft ²)	NEMA LOAD WK ² (lb-ft ²)	MAX ALLOWABLE WK ² (lb-ft ²)	NEMA LOAD WK ² Sec	MAX ALLOWABLE WK ² Sec	COLD	HOT
442.00	130	100	220	52	640	1280	5.33	10.26	2	1

APPROVED:	M. PRATER	DRAWING NO.	31057NP1504C	REVISION:	1
-----------	------------------	-------------	---------------------	-----------	----------

DATE:
OCTOBER 30, 2014

CONNECTION DIAGRAM

CATALOG NO.:
NP1504C



SCHEMATIC - Δ / Y CONNECTION

ACROSS THE LINE CONNECTION



LINE
230 VOLT CONNECTION

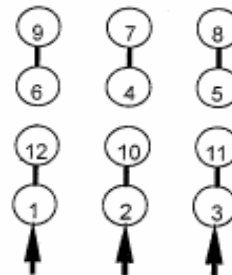

LINE
460 VOLT CONNECTION

***CONTACT TWMC IF YOU HAVE ANY QUESTIONS
REGARDING THE MOTOR CONNECTION.**

PH: 1-800-873-8326