

DATE MAY 06, 2017	OUTLINE DIMENSIONS 3-PHASE INDUCTION MOTOR	MOTOR TYPE: AEUH8PCF
CATALOG NO.: NPVO306C		FRAME NO. 326TC

Pole	HP	kW	Hz	VOLT	r/min
6	30	22.4	60	230/460	1200

Ins	Rating	Dimension in	Approx Weight	Bearings	
F	CONT.	inches	777	DE: 6312	NDE: 6212

Totally Enclosed Fan-cooled Vertical Type. Squirrel-cage Rotor.

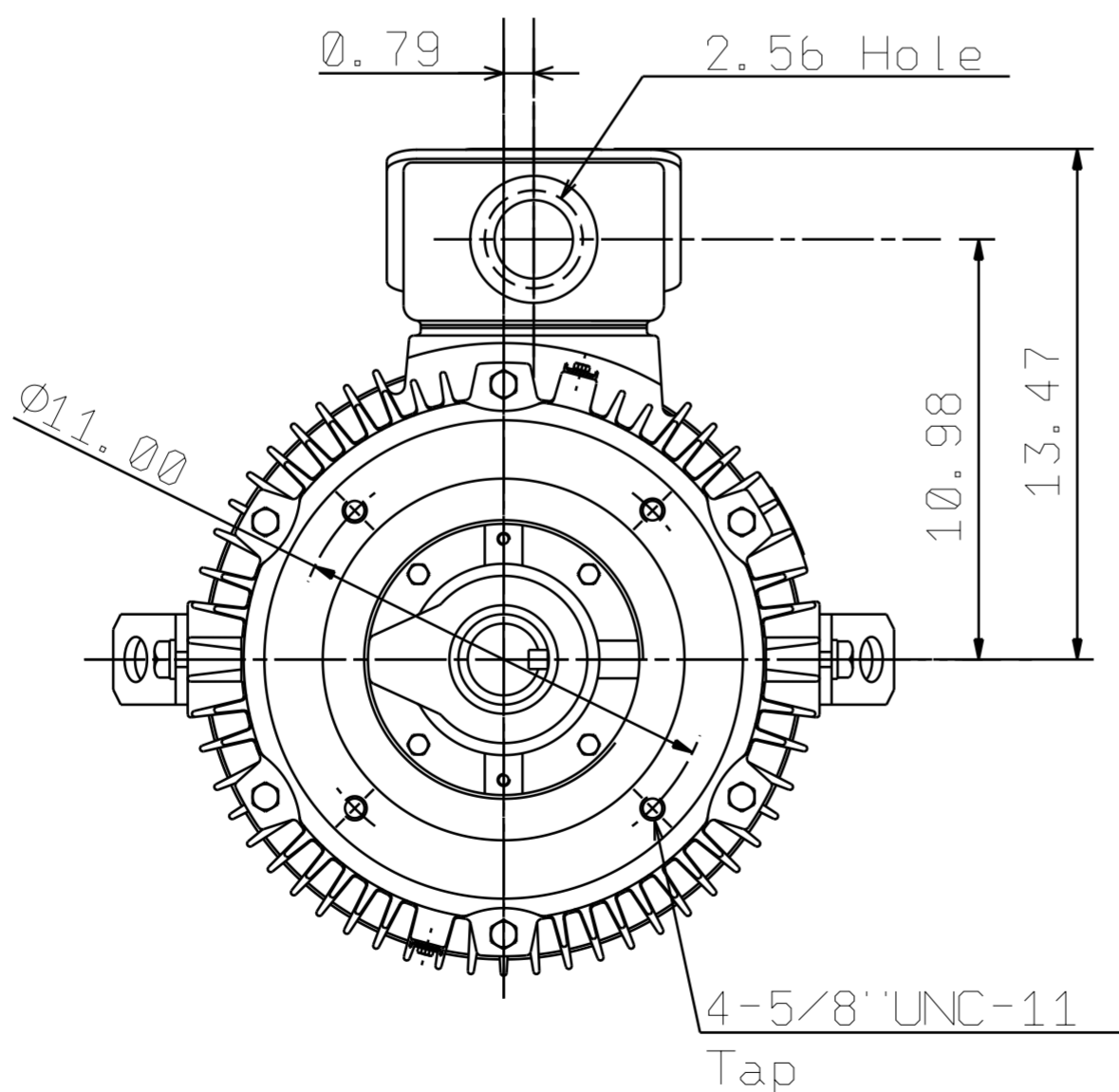
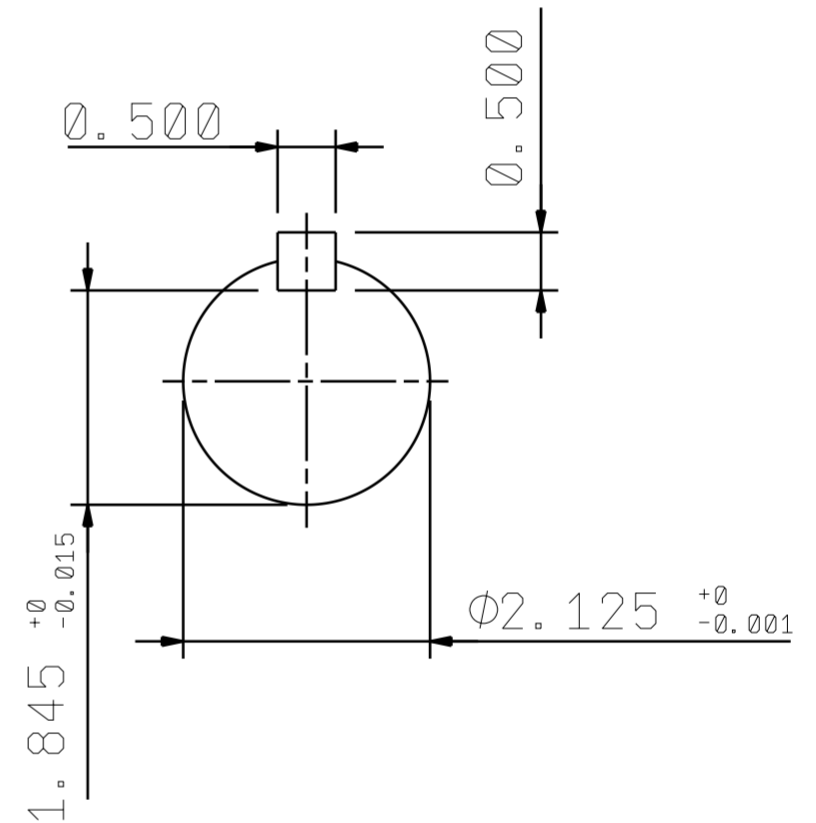
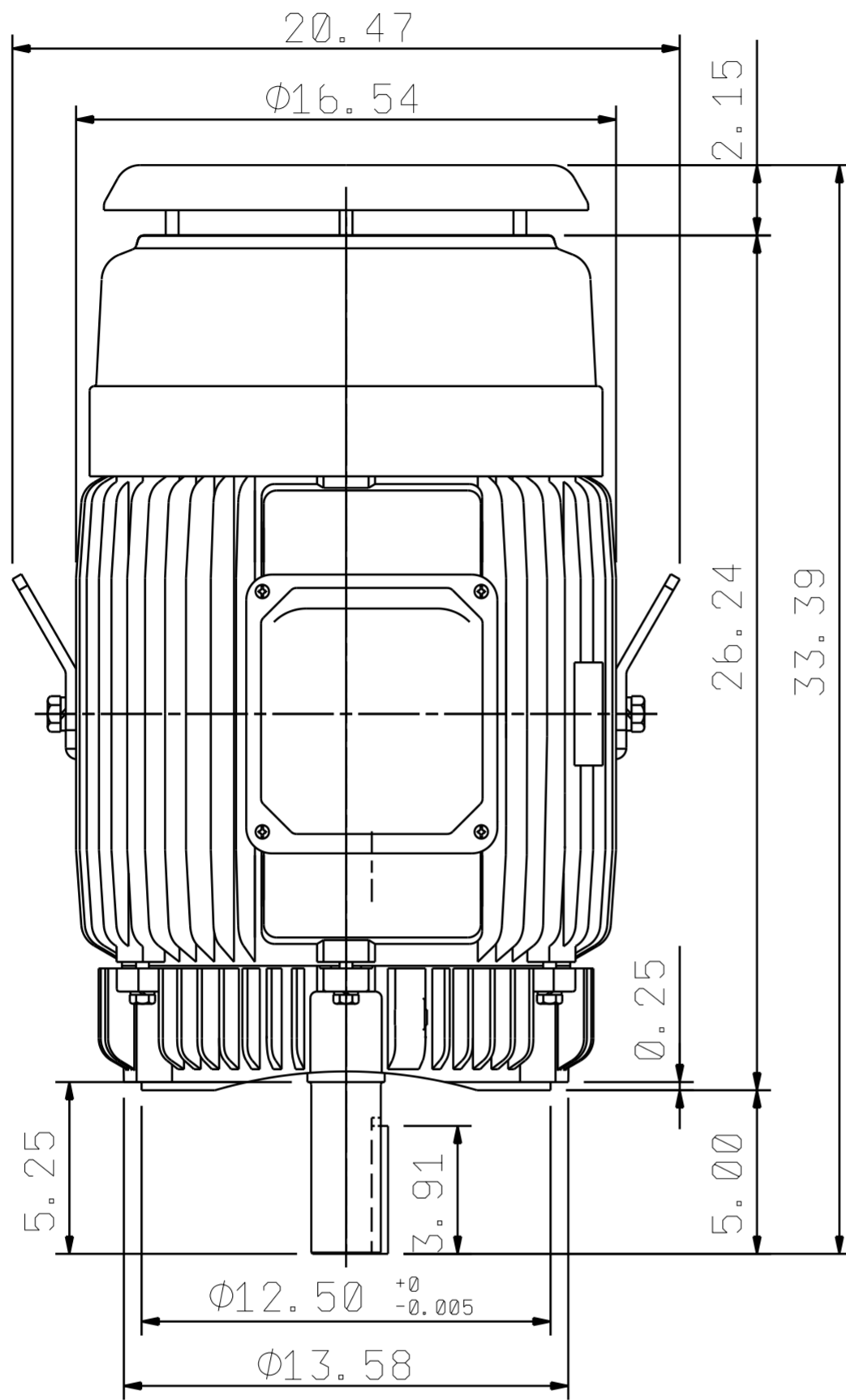

NOTES:

- ENCLOSURE: IP54.
- FOR DIRECT FLEXIBLE COUPLING.

TA17142-00-01

DWG.	04.17.17		DWG NO.
CHKD.	04.17.17		31057A534210
APPD.	04.17.17		

TECO Westinghouse

ISSUED 5/21/2017	PERFORMANCE DATA 3-PHASE INDUCTION MOTOR	ENCLOSURE TEFC
TYPE AEUH8PDC		CATALOG# NPV0306C

NAMEPLATE INFORMATION

OUTPUT		POLE	FRAME SIZE	VOLTAGE	HZ	RATED AMBIENT	INS. CLASS	NEMA DESIGN	TIME RATING	SERVICE FACTOR
HP	KW									
30	22.4	6	326TC	230/460	60	40°C	F	B	CONT.	1.15

VARIABLE FREQUENCY DRIVE SERVICE

VARIABLE TORQUE				OHMS/PHASE EQUIVALENT WYE CIRCUIT (AT RATED OPERATING TEMPERATURE 25°C)				
HZ	HP	RPM	TORQUE (lb-ft)	R1	R2	X1	X2	X _m
3~60	0.0038~30	60~1200	0.332~134.1	0.1129	0.2135	0.6729	1.1569	22.143

CONSTANT TORQUE				CONSTANT HORSEPOWER			
HZ	HP	RPM	TORQUE (lb-ft)	HZ	HP	RPM	TORQUE (lb-ft)
6~60	3~30	120~1200	134.1	60~90	30	1200~1800	134.1~89.4

TYPICAL PERFORMANCE

FULL LOAD RPM	EFFICIENCY				POWER FACTOR			SOUND PRESSURE LEVEL @ 3 FT Db(A)
	FULL LOAD		3/4 LOAD %	1/2 LOAD %	FULL LOAD %	3/4 LOAD %	1/2 LOAD %	
	MIN.%	NOM.%						
1175	91.7	93	93.6	93.6	80.5	78.5	71	72

CURRENTS									NEMA KVA CODE LETTER	SAFE STALL TIME IN SECONDS	
NO LOAD			FULL LOAD			LOCKED ROTOR				COLD	HOT
AT 208 VOLT	AT 230 VOLT	AT 460 VOLT	AT 208 VOLT	AT 230 VOLT	AT 460 VOLT	AT 208 VOLT	AT 230 VOLT	AT 460 VOLT			
20.60	23.20	11.6	83.00	75.00	37.50	394.3	436.0	218	G	17	12

TORQUE				INERTIA			ACCEL TIME (DOL)		ALLOWABLE STARTS PER HOUR	
FULL LOAD (lb-ft)	LOCKED ROTOR %FLT	PULL UP %FLT	BREAK DOWN %FLT	ROTOR WR ² (lb-ft ²)	NEMA LOAD WK ² (lb-ft ²)	MAX ALLOWABLE WK ² (lb-ft ²)	NEMA LOAD WK ² Sec	MAX ALLOWABLE WK ² Sec	COLD	HOT
134.10	210	180	230	12.372	384	636	5.59	9.15	2	1

APPROVED:	M. PRATER	DRAWING NO.	31057NPV0306C	REVISION:	1
-----------	------------------	-------------	----------------------	-----------	----------

DATE:
September 13, 2006

CONNECTION DIAGRAM

CATALOG NO.:
NPV0306C



SCHEMATIC - Δ / Y CONNECTION

ACROSS THE LINE CONNECTION

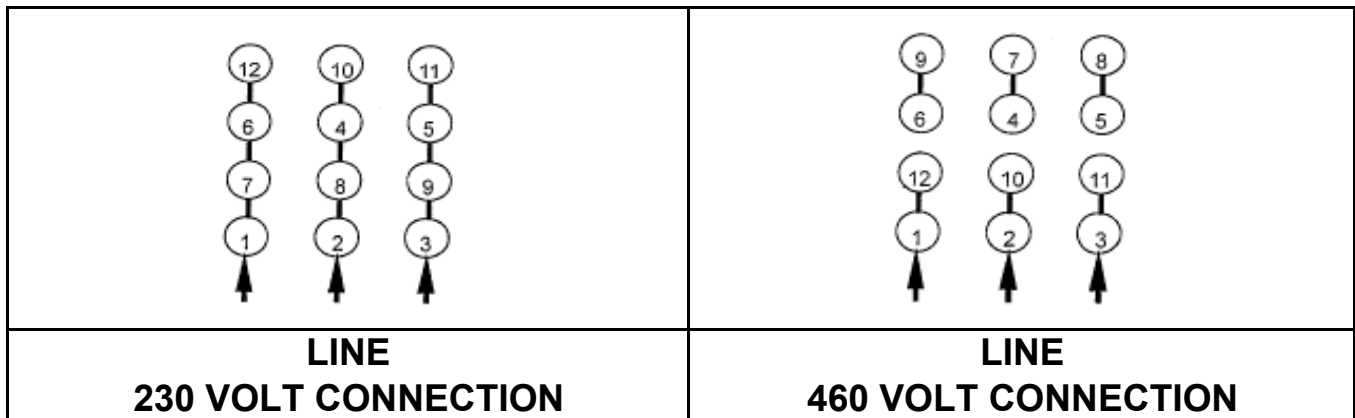

WYE START-DELTA RUN CONNECTION

