

TOSHIBA

TOSHIBA INTERNATIONAL CORPORATION

LOW VOLTAGE MOTORS

Low Voltage 50 & 60 Hz Motor

DN: 195-0014 Rev.007 - August 2021

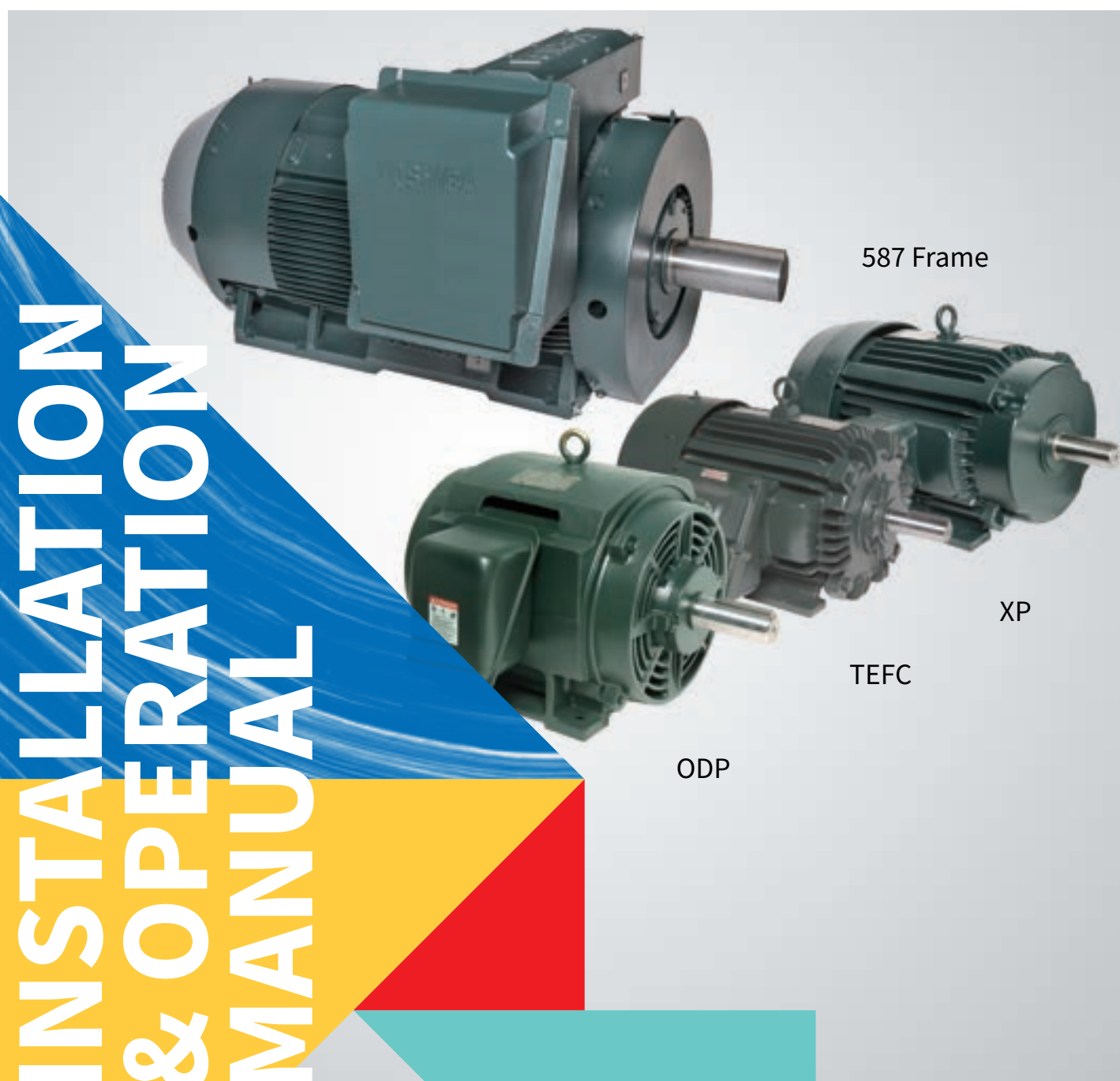

LOW-VOLTAGE 50 / 60 Hz MOTOR
Installation and Operation Manual

DN: 195-0014 Rev. 007
August, 2021

Introduction

Thank you for choosing Toshiba and congratulations on the purchase of the **Low Voltage 50/60 Hz Motor!**

This manual provides information on how to safely install, couple to the driven equipment, and maintain the Toshiba Squirrel Cage Low-Voltage Induction Motor.

The squirrel cage induction motor was designed for an extended service life under very demanding conditions. However, should the motor require service, this manual includes a section that assists the repair technician with maintenance, disassembly/assembly, part replacement, testing, and troubleshooting.

Maintenance recommendations include inspection requirements, cleaning methods, bearing lubrication, disassembly support, and testing methods.

All Toshiba motors are manufactured, inspected, and tested to rigid standards that are equal to or to exceed the standards required by the National Electrical Manufacturer's Association (NEMA), National Electrical Code (NEC), American National Standards Institute (ANSI), and testing per Institute of Electrical and Electronic Engineers (IEEE) Standard 112.

For ALL references to the National Electrical Code (NEC), see the latest release of the National Electrical Code.

About This Manual

This manual was written by the Toshiba International Corporation Technical Publications Group. This group is tasked with providing technical documentation for the Toshiba Low-Voltage 50 & 60 Hz Motor. Every effort has been made to provide accurate and concise information to you, our customer.

At Toshiba International Corporation we are continuously striving for better ways to meet the constantly changing needs of our customers. E-mail your comments, questions, or concerns about this publication to TIC-Technical-Communications-Dept@toshiba.com.

Purpose and Scope

This manual provides information on the various features and handling procedures including:

- Installation,
- Alignment and coupling,
- System operation,
- Maintenance, and
- Spare parts recommendations.

The information contained in this manual apply to the following typeforms only:

- Frames 143 through 5810 Open Drip Proof (ODP),
- Frames 56 through 5811 Totally Enclosed Fan Cooled (TEFC),
- Frames 143 through 449 Explosion Proof (XP),
- Frames 56 through 5811 Totally Enclosed Air-Over (TEAO),
- Frames 56 through 449 Totally Enclosed Non-Ventilated (TENV), and
- Frames 143 through 5811 Totally Enclosed Blower Cooled (TEBC).

Included is a section on general safety instructions that describe the warning labels and symbols that may be used on the motor and throughout the manual. Read the manual completely before installing, operating, performing maintenance, or disposing of the motor.

This manual and the accompanying drawings should be considered a permanent part of the equipment and should be readily available for reference and review at the installation site. Dimensions shown in the manual are in English and/or the metric equivalent.

Because of our commitment to continuous improvement, Toshiba International Corporation reserves the right, without prior notice, to update information, make product changes, or to discontinue any product or service identified in this publication.

Toshiba International Corporation (TIC) shall not be liable for direct, indirect, special, or consequential damages resulting from the use of the information contained within this manual.

This manual is copyrighted. No part of this manual may be photocopied or reproduced in any form without the prior written consent of Toshiba International Corporation.

© Copyright 2021 Toshiba International Corporation.

TOSHIBA[®] is a registered trademark of Toshiba Corporation. All other product or trade references appearing in this manual are registered trademarks of their respective owners.

All rights reserved.

Printed in the U.S.A.

Contacting the TIC Customer Support Center

Toshiba International Corporation's Customer Support Center can be contacted to obtain help in resolving any motor problem that you may experience or to provide application information.

The Support Center is open from 8 a.m. to 5 p.m. (CST), Monday through Friday. The Center's toll free number is US (800) 231-1412 or (855)803-7091/Local (713) 466-0277/ Fax (713) 896-5252 CAN (800) 872-2192 MEX 01 (800) 527-1204.

For after-hours support, follow the directions in the outgoing message when calling.

You may also contact Toshiba International Corporation by writing to:

Toshiba International Corporation
13131 West Little York Road
Houston, Texas 77041-9990
Attn: Low-Voltage Motor Marketing Department

For further information on Toshiba International Corporation's products and services, please visit our website at www.toshiba.com/tic/.

TOSHIBA INTERNATIONAL CORPORATION

Low Voltage 50 & 60 Hz Motor

Complete the following information and retain for your records.

Model Number: _____

Serial Number: _____

Project Number (if applicable): _____

Date of Installation: _____

Inspected By: _____

Name of Application: _____

Important Notice

The instructions contained in this manual are not intended to cover all details or variations in equipment types. Nor may it provide for every possible contingency concerning the installation, operations, or maintenance of this equipment. Should additional information be required, contact the [Customer Support Center](#).

Any electrical or mechanical modifications to this equipment without the prior written consent of Toshiba International Corporation may void all warranties and may void the UL/CSA listing or other safety certifications. Unauthorized modifications may also result in a safety hazard or equipment damage.

Misuse of this equipment could result in injury and/or equipment damage. In no event will Toshiba International Corporation be responsible or liable for direct, indirect, special, or consequential damage or injury that may result from the use or misuse of this equipment or information contained within this manual.

Warranty Information

The warranty contained in Toshiba International Corporation's Standard Terms and Conditions of Sale ("TIC Standard Warranty") available at https://www.toshiba.com/tic/cms_files/TCofSale.pdf shall be the sole warranty, unless a different warranty is provided in the applicable contract between the parties ("Contract Warranty"), in which case the Contract Warranty shall be the sole warranty. Any statements herein do not create any new warranties or modify the TIC Standard Warranty or the Contract Warranty, as applicable.

Activating the TIC Warranty

To activate the TIC warranty for the received equipment go the Toshiba General Warranty & Product Registration site at <https://www.toshiba.com/tic/service-warranty/general-warranty-product-registration>.

Complete the required fields of the form and click Submit.

A warranty confirmation will be mailed to the registered contact entity.

Table of Contents

General Safety Information	1
Safety Alert Symbol	1
Signal Words	1
Special Symbols	1
Equipment Warning Labels	1
Qualified Personnel	2
Receiving and Storage	3
Receiving	3
Storage	3
Motor Installation	4
Installation Precautions	4
Location.....	4
Unpacking.....	4
Mounting the Motor	4
Foundation	5
Anchor Bolt.....	5
Mounting Foundation.....	6
Bedplate Installation and Leveling.....	6
Grouting	7
Motor Leveling and Coupling	8
Rigid Coupling	8
Shaft Alignment.....	8
Coupling Faces	8
Balancing Direct-Coupled Motors	8
Flexible Coupling	9
Vibration.....	9
V-Belt Specifications.....	10
Motor Operation	12
Motor Start-Up Precheck	12
Operation Precaution	12
Motor Precheck.....	12
Motor Testing	12
Maintenance	13
Cleanliness	13
Insulation Resistance	13
Recommended Practice for Drying.....	13
Apply External Heat.....	13
Apply Direct Current.....	14
Motor Lubrication	15
Lubrication Specifications	15

Standard Service	15
Recommended Greases	16
Heating of Bearings.....	18
Overheating of Antifriction Bearings.....	18
Motor Disassembly and Reassembly	19
Remove/Replace Bearings	19
Remove the Bearings.....	19
Install the Bearings.....	20
Installation.....	20
Rotor Removal	20
Lifting the Rotor	21
Removing the Rotor.....	21
Inserting the Rotor.....	21
Electrical Testing	22
Power Supply	22
Motor Terminals and Connectivity	22
Field Insulation Test	22
Effect of Altitude on Temperature Rise	23
Special Equipment (Accessories)	24
Space Heaters	24
Stator Temperature Detectors	24
Resistance Temperature Detectors.....	24
Thermocouple	24
Bearing Temperature Detectors	24
Air Filters	24
Ordering Information and Spare Parts	25
Ordering Information.....	25
Spare Parts Listing	25
Disposal	25
Service Guide	26

General Safety Information

DO NOT attempt to install, operate, perform maintenance, or dispose of this equipment until you have read and understood all of the product safety information and directions that are contained in this manual.

Safety Alert Symbol

The **Safety Alert Symbol** is comprised of an equilateral triangle enclosing an exclamation mark. This indicates that a potential personal injury hazard exists.

Signal Words

Note: For each safety alert symbol used within this manual all sub symbols also apply (i.e., Using the danger symbol means that the warning and caution applicables are in effect for that instance, too).

Listed below are the signal words that are used throughout this manual followed by their descriptions and associated symbols. When the words DANGER, WARNING, and CAUTION are used in this manual, they will be followed by important safety information that must be carefully followed.



DANGER

The word DANGER preceded by the safety alert symbol indicates that an imminently hazardous situation exists that, if not avoided or if instructions are not followed precisely, will result in serious injury to personnel or loss of life.



WARNING

The word WARNING preceded by the safety alert symbol indicates that a potentially hazardous situation exists that, if not avoided or if instructions are not followed precisely, could result in serious injury to personnel or loss of life.



CAUTION

The word CAUTION preceded by the safety alert symbol indicates that a potentially hazardous situation exists that, if

not avoided or if instructions are not followed precisely, may result in minor or moderate injury.

The word CAUTION without the safety alert symbol indicates that a potentially hazardous situation exists that, if not avoided or if instructions are not followed precisely, may result in equipment and/or property damage.

Special Symbols

To identify special hazards, other symbols may appear in conjunction with the DANGER, WARNING, and CAUTION signal words. These symbols indicate areas that require special and/or strict adherence to the procedures to prevent serious injury to personnel or loss of life.

Electrical Hazard Symbol



A symbol that is comprised of an equilateral triangle enclosing a lightning bolt indicates a hazard of injury from electrical shock or burn.



Explosion Hazard Symbol

A symbol that is comprised of an equilateral triangle enclosing an explosion indicates a hazard of injury from exploding parts.

Equipment Warning Labels

DO NOT attempt to install, operate, perform maintenance, or dispose of this equipment until you have read and understood all of the product labels and user directions that are contained in this manual.

Warning labels that are attached to the equipment will include the exclamation mark within a triangle. **DO NOT** remove or cover any of these labels. If the labels are damaged or if additional labels are required, contact the Toshiba [Customer Support Center](#).

Labels attached to the equipment exist to provide useful information or to indicate an imminently hazardous situation that may result in serious injury, severe property and equipment damage, or loss of life if safe procedures or methods are not followed as outlined in this manual.

Qualified Personnel

Installation, operation, and maintenance shall be performed by **Qualified Personnel Only**. A Qualified Person is one that has the skills and knowledge relating to the construction, installation, operation, and maintenance of the motor and the motor driven equipment. In conjunction with the aforementioned, will be familiar with the electrical equipment and will have received safety training on the hazards involved with motor operation (Refer to the latest edition of NFPA 70E for additional safety requirements).

Qualified Personnel shall:

- Have read and understood the entire manual.
- Be familiar with the construction and function of the motor, the equipment being driven, and the hazards involved.
- Be able to recognize and properly address hazards associated with the application of motor-driven equipment.
- Be trained and authorized to safely energize, de-energize, ground, lock out/tag out circuits and equipment, and clear faults in accordance with established safety practices.
- Be trained in the proper care and use of protective equipment such as safety shoes, rubber gloves, hard hats, safety glasses, face shields, flash clothing, etc., in accordance with established safety practices.

For further information on workplace safety, visit www.osha.gov.

Receiving and Storage

Receiving

Ensure that the nameplate data is consistent with the order specifications.

Ensure that no damage has occurred during transportation. Typically, motors are shipped FCA TIC factory. In the event that damage has occurred during shipping, freight claims must be submitted by the consignee to the carrier.

Remove the bearing lock plate before start up (if used). Save the bearing lock plate for reuse if subsequent shipping may be required.

If unable to reinstall the bearing lock plate, use wooden wedges to block the shaft — this will prevent any movement during shipping.

Turn the shaft by hand to ensure that it turns freely.

Storage

If the equipment is not put into immediate use, it should be stored indoors in an area that is clean and dry. Care should be taken to keep the equipment covered when moving from a cold location to a warm location, otherwise condensation may occur. If condensation does occur, allow the motor to dry thoroughly before applying power.

Before applying power to the motor, use a megohmmeter to test the insulation resistance of the windings. A minimum of 10 megohms is recommended.

For long-term storage or when indoor storage is not available, the motor must be covered with plastic or weather-proof tarp. Cover the motor completely. To ward off the formation of condensation, do not wrap the motor tightly. This will allow for adequate ventilation. Precautions must also be taken to

protect the motor from flooding or being exposed to harmful chemical vapors.

Ensure that any unpainted sections are covered. Retouch any scratched or flaked areas.

If condensate plugs or drain plugs are used, ensure that they are functional.

Whether indoors or outdoors, the storage area should be free from vibration. Excessive vibration can cause bearing damage. If the motor must be stored in a location that would expose it to vibration, it must have the shaft locked to prevent any shaft movement.

If the motor is equipped with space heaters, ensure that the space heaters are properly connected and functional. The motor interior temperature should be maintained approximately 5.6° C (10° F) degrees above the ambient temperature.

A systematic inspection and maintenance schedule should be established. If the motor is to be stored for 6 months or longer, it should, in addition to the precautions above, be tested using a megohmmeter to measure the insulation resistance of the windings every 3 to 6 months. A minimum of 10 megohms is recommended.

A record of the temperature, time, humidity, insulation resistance readings, and length of time that the voltage is applied should be recorded to show winding conditions prior to start up.

If windings are designed for outdoor operation, they will not be affected by extreme or sudden temperature changes, or inclement weather in general. However, a weather proof cover with provisions for adequate ventilation should be used to guard against intrusion of salt, dust, or other abrasive or corrosive materials.

It is recommended that the rotor be turned every month to redistribute the lubricant in the bearings. Oil or grease should be added every 6 months.

Motor Installation Installation Precautions

To reduce the risk of fire or explosion, do not install Division 2 motors in areas where the operating temperature code (shown on the motor nameplate or Division 2 label) exceeds the ignition temperature of the hazardous environment.

Do not attempt to install, operate, maintain or dispose of this equipment until you have read and understood all the product safety information and directions that are contained in this manual.

Do not disable or bypass any safety guards or protective devices.

Two people are required to lift a 140 frame motor.

Protection for overloads, peak starting currents, short circuit current, and ground fault currents, should be in strict accordance with the National Electrical Code Article 430, local electrical codes, and building codes.

Proper circuit protection is required to prevent automatic reset devices from restarting the motor automatically.

Only qualified personnel are to install or perform maintenance on this equipment.

Location

The motor should be installed in an area of unrestricted ventilation. Ensure that there are no limits or obstructions imposed on the operation of the motor.

Drip proof motors are designed for indoor installations where the atmosphere is reasonably free of dirt, moisture, and corrosion. Contact the TIC [Customer Support Center](#) for any required modifications.

Totally enclosed motors may be installed where dirt, moisture (not running water), and corrosion are present. Outdoor applications of totally enclosed motors are acceptable — subject to the environment. Contact the TIC [Customer Support Center](#) for any required modifications.

Explosion proof motors are designed and built for hazardous locations. Listed by UL for Class 1, Group D and Class II, Groups E, F and G; temp code T3B (165C), Division 1. Also listed by C.S.A.

Unless otherwise specified, the ambient operating temperature is -25° to 40° C (-13° to 104° F).

Install the motor in a location that is easily accessible for cleaning, inspection, and maintenance — this includes being away from walls and other obstructions to permit a free passage of air.

Avoid installation locations that would allow exposure to coal/mill dust, leaky pipes, steam/moisture, acids, alkalines or the fumes thereof, or any other harmful substances.

Do not install the motor in an area where flammable gases or combustible material may be present, or around any hazardous processes, unless designed for such an application.

Unpacking

If the motor has been exposed to a low temperature, do not remove the coverings until the motor has had sufficient time to attain a temperature that is close to that of the room in which it is to be unpacked.

Otherwise, when opened, moisture will condense on the cold parts. This may reduce the electrical resistance of the insulation or allow for the oxidation of metallic parts.

Each Toshiba International Corporation (TIC) electric motor is thoroughly tested at the factory and carefully packaged for standard shipping. Confirm the overall packaging condition upon receipt.

Mounting the Motor

Mount the motor securely on a firm and flat base. All ball (spherical) and roller (cylindrical) bearing normal-thrust motors through frame 447 are mechanically capable of being mounted in any position. Consult with the TIC [Customer Support Center](#) for frames larger than 447. Special drains, seals, or support construction may be required on all sizes — actual requirements will be application specific.

Align the motor accurately using a flexible coupling, if possible. For drive recommendations, consult with the drive manufacturer, equipment manufacturer, or TIC Customer Support Center. See additional information in the section titled [Motor Leveling and Coupling on pg. 8](#).

Ball bearings are recommended for direct-coupled applications. Roller bearings may be used with flexible couplings — ensure proper alignment. Rigid couplings require extra allowance for thermal shaft

growth toward the coupling. Skidding noise may result from the combination of internal bearing clearances and alignment tolerances.

CAUTION

DO NOT RUN A ROLLER BEARING WITHOUT A LOAD CONNECTED.

V-belt sheave pitch diameters should not be less than the values listed in [Table 1 on page 10](#) (NEMA recommended values) or calculated from the formula for frames above 445T.

Tighten belts enough to prevent slippage only. Typically, belt speed should not exceed 6500 ft. per minute. Consult the belt/sheave supplier for special applications.

Motors must not be subjected to vibration exceeding 0.5 G force. Motors are not to be mounted to shaker screens or vibrating equipment that will allow for vibration in excess of 0.5 G force to be exerted onto the motor. Complete vibration isolation is required.

Foundation

A rigid foundation is necessary for smooth, stable, and reliable operation.

A satisfactory bond between the foundation and the grouting is required. The foundation surface must be roughened (if not cured rough) and cleaned

before the bedplate or soleplate (hereinafter called bedplate) is secured to it.

Anchor Bolt

The purpose of anchor bolts is to secure the motor and bedplate to the foundation such that, structurally, the foundation, motor, and bedplate become a single mass (see [Mounting Foundation on pg. 6](#)).

The bolt is enclosed in a casing three or four diameters larger than the bolt. This allows the bolt to be sprung horizontally when placing the motor bedplate in position for mounting — this permits slight adjustments for errors in the bolt position. Concrete is not placed inside of the casing at the time that the foundation is poured. Instead, the casing is filled with grout at the time that the motor is finally grouted into position.

A foundation template, pattern, or frame, usually fabricated from wood, should be used to support the bolts and casings while the foundation is being built up around them. The dimensions required in constructing the supporting frame for the bolts and casings may be obtained from construction diagrams or by measuring the base of the motor.

The motor should be mounted securely onto a bedplate that is rigid enough to prevent any base-to-motor or motor-to-base vibration. The base must not impose bending or twisting strains on the motor housing.

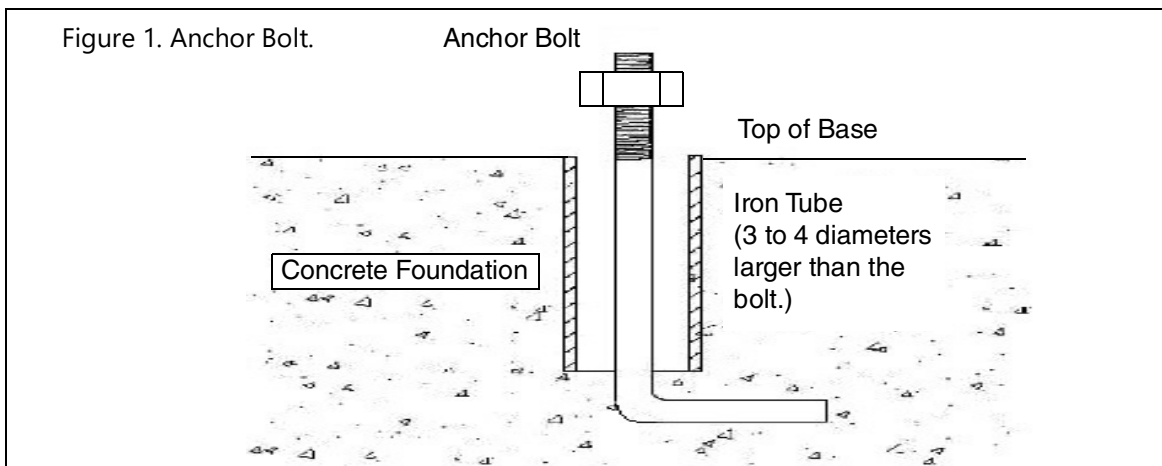

Mounting Foundation

When mounting the motor, use of slotted shims is recommended as it may be necessary to remove or add shims when aligning the shafts. The use of proper shims inserted under each mounting foot will

prevent distortion of the motor housing when the mounting bolts are secured.

The following procedure is recommended for mounting the motor.

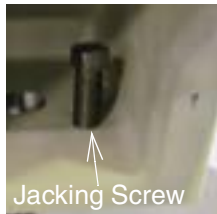
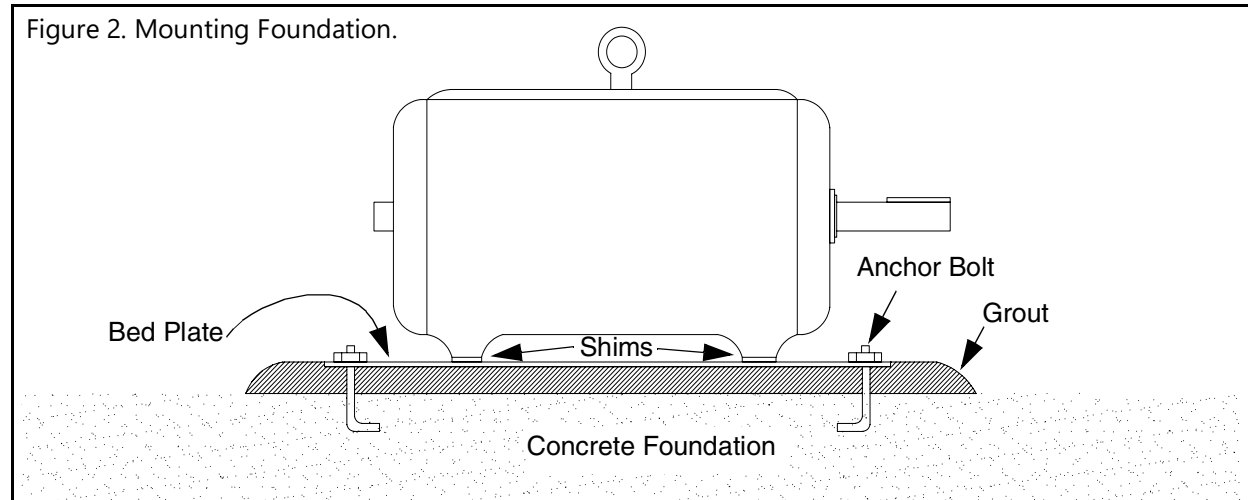

Where available, use the Jacking Screw to raise or lower the motor when shimming. Shims used shall be the same size as the mounting foot of the motor.

Identify the mounting foot of the motor that will require the most shims and install shim(s) to that mounting foot.

Tighten the mounting foot bolt.

Insert feeler the gauge under the remaining mounting feet to determine the thickness of the shims required.

Insert the required number of shims under each mounting foot and tighten the mounting bolts.

Use a small number of thick shims rather than a large number of thin shims (0.200" maximum).

Note: Shims shall cover at least 75% of the foot area.

Measure the alignment and, using shims, continue to adjust as required.

Bedplate Installation and Leveling

Install the bedplate onto the foundation by performing the following procedure.

1. Place $\frac{3}{4}$ " – 1" thick iron wedges onto the foundation at the motor mounting location.

Note: The iron wedges shall cover at least 75% of the motor mounting footprint.

2. Position the iron wedges equally spaced and close to the anchor bolts.
3. Place the bedplate onto the foundation.
4. Use the iron wedges to position and level the bedplate onto the foundation.
5. Secure the bedplate onto the foundation using the anchor bolts.
6. Torque the anchor bolts securely.

The $\frac{3}{4}$ " – 1" of space between the foundation and the bedplate is to be filled with grout.

DO NOT remove the wedges when grouting the bedplate — wedges are to properly sized for the application so as not to interfere with the grout form.

Grouting

The foundation mounting surface must be rough and clean to provide good grout anchorage. The grout shall be of the non-shrinking type.

Apply the grouting between the foundation and the bedplate by performing the following procedure.

1. Wash the top of the foundation.
2. Where possible, build a form (border) that extends 2" around the periphery of the bedplate area. The form is used to contain the grout during the grout application.
3. Pour and pack in the grout.
4. Grout in by building a low dam around the inside and outside of the bedplate. Where possible, allow grout to extend beyond the bedplate periphery 2" on all sides.
5. Pack the grout to a height of ½" above the underside of the bedplate.

Note: If the grouting is too deep, it will increase the difficulty in removing the motor during any subsequent repair or maintenance operations.

A properly constructed base provides a stable platform for motor operation.

Motor Leveling and Coupling

A properly constructed base in conjunction with using the correct shims combine to create a very stable platform.

Rigid Coupling Shaft Alignment

Extreme care must be taken to obtain correct shaft alignment when using rigid couplings. Circular concentric peripheral surfaces of the two coupling halves must indicate correct alignment to within 0.0005 inches (0.0127 mm) to 0.001 inches (0.0254 mm) when the two coupling halves are rotated together. The separation between the faces of the two coupling halves must also be maintained within the same tolerance (see [Figure 3. on pg. 9](#)).

The alignment may be checked by utilizing a dial indicator, or with the aid of a straight-edge and thickness gauge or feelers as shown on [pg. 9](#).

The preferred method of checking alignment is with the dial indicator. Bolt the indicator to one of the coupling halves and indicate the position of the dial button on the opposite coupling half with a chalk mark. Set the indicator dial to zero at the first position and then rotate both halves of the coupling to a new position where a reading is to be made. All readings must be made with the dial button located at the chalk mark. At least six readings are to be taken.

A variation in the dial reading at different positions of coupling rotation will indicate whether the machine has to be raised, lowered, or moved to one side or another to obtain alignment of the circular concentric peripheral surfaces of the two coupling halves within the specified tolerance.

Coupling Faces

In addition to the circular concentric peripheral surface check, a check of the separation of the coupling faces must be made to establish correct alignment. The separation between the faces of the coupling may be checked with a dial indicator fastened to one coupling half and a reference surface fastened to the other coupling half. Mark the location of the dial button on the reference surface and make all readings with the indicator in this position.

Set the dial of the indicator to zero for the first reading and use this as the reference. Be sure to rotate both halves of the coupling the same amount, aligning the bottom of the indicator and the mark on the reference surface for each of six readings. A variation of the readings at different positions will indicate how the machine has to be adjusted to obtain correct alignment. After each adjustment of the motor, repeat the above procedure to ensure that the correct alignment and leveling have been obtained (see [Figure 3. on pg. 9](#)).

Balancing Direct-Coupled Motors

Toshiba motors are balanced at the factory to industry standard tolerances. Field disassembly/assembly may result in unbalanced operation. Should this occur, disconnect the coupling halves and rotate one shaft 90° with respect to the other shaft. Re-connect the coupling and run the motor.

If the unbalanced condition persists, disconnect and rotate the same shaft another 90° with respect to the other shaft until balanced operation resumes.

If a chain, gear, V-belt, or flat belt drive is used on the output shaft, perform a minimum sprocket diameter check.

Direct coupling via a flexible means does not require a check for minimum sprocket diameter.

Figure 3. Direct Coupling Checks.

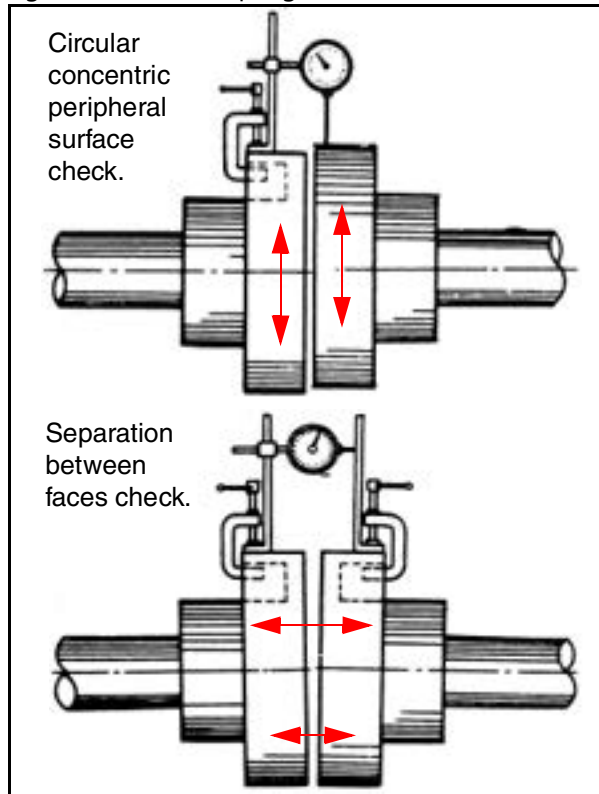

halves will be indicated by the straight-edge and feeler gauge test.

When the coupling halves have been correctly aligned with the motor feet bolted in position, place temporary bolts in two coupling holes for clamping the halves together. Then, ream for a light drive fit through both halves for regular coupling bolts.

The preferred method of measuring coupling alignment is with a dial indicator as shown in Figure 3. Clamp the dial indicator to the coupling as indicated to measure the circular concentric peripheral surfaces of the coupling halves for parallel alignment.

Also, as shown in Figure 3., clamping a reference surface to the opposite coupling half allows the dial indicator to be used for measuring the separation of the coupling halves for axial alignment.

Vibration

On new installations excessive vibration may be encountered while running. Listed below are some of the more common causes.

- Improper shimming and/or a soft foot.
- Misalignment.
- Shafts of the motor and load are not properly aligned.
- Unbalanced load.
- Worn bearings on the motor and/or the driven machine.
- A resonant mounting condition — the effect is increased when the motor is coupled to the load.
- Vibration of the driven equipment.
- Sprung shafting.
- Improper or cracked foundation.
- Electrical imbalance.
- Rotor imbalance.

Seek the simple solution first.

lists acceptable vibration test limit levels. A vibration detector will be required to measure the system vibration levels.

After satisfactory alignment and vibration testing, install dowel pins in the base of the motor and in the bases of the driven equipment. This will prevent creeping and subsequent misalignment during operation.

Flexible Coupling

Units coupled through flexible couplings should be aligned as accurately as possible. The two halves should indicate correct alignment to within 0.002 inches (0.0508 mm) on both the circular concentric peripheral surfaces and the separation between faces. Although most flexible couplings will withstand greater misalignment than rigid couplings, extreme misalignment can cause vibration possibly resulting in failure of motor bearings and/or shaft.

If the method shown in Figure 3. is used to check alignment of the machines, correct alignment exists when:

The peripheries of the coupling halves are true circles of the same diameter and if the faces are flat.

The separation between the faces is held to within the specified tolerance at all points and a straight-edge lies squarely across the rims at any point.

Non-parallel faces will be indicated by a variation in separation of the coupling halves as they are rotated, and a difference in height of the coupling

V-Belt Specifications

Table 1. V-Belt Sheave Pitch Diameters (MG 1-14.42).

Frame Number	Horse Power at Synchronous Speed RPM			V-Belt Sheave (Inches)			
				Conventional		Narrow	
				A, B, C, D, and E		3V, 5V, and 8V	
3600	1800	1200	Min. Pitch Diameter	*Max. Width	Min. Pitch Diameter	**Max. Width	
143T	1.5	1.0	0.75	2.2	4.250	2.2	2.250
145T	2 – 3	1.5 – 2	1.0	2.4	4.250	2.4	2.250
182T	3.0	3.0	1.5	2.4	5.250	2.4	2.750
	5.0	—	—	2.6			2.750
184T	—	—	2.0	2.4	5.250	2.4	2.750
	5.0	—	—	2.6			
	7.5	5.0	—	3.0			
213T	7.5 – 10	7.5	3.0	3.0	6.500	3.0	3.750
215T	10	—	5.0	3.0	6.500	3.0	3.750
	15	10	—	3.8		3.8	
254T	15	—	7.5	3.8	7.750	3.8	4.000
	20	15	—	4.4		4.4	
256T	20 – 25	—	10	4.4	7.750	4.4	4.000
	—	20	—	4.6			
284T	—	—	15	4.6	9.000	4.4	4.250
	—	25	—	5.0			
286T	—	30	20	5.4	9.000	5.2	4.250
324T	—	40	25	6.0	10.250	6.0	5.250
326T	—	50	30	6.8	10.250	6.8	5.250
364T	—	—	40	6.8	11.500	6.8	5.250
	—	60	—	7.4		7.4	5.250
365T	—	—	50	8.2	11.500	8.2	5.500
	—	75	—	9.0		8.6	
404T	—	—	60	9.0	14.250	8.0	7.250
	—	100	—	10.0		8.6	
405T	—	—	75	10.0	14.250	10.0	7.250
	—	100	—			8.6	
	—	125	—			11.5	
444T	—	—	100	11.0	16.750	10.0	8.500
	—	125	—			9.5	
	—	150	—			—	
445T	—	—	125	12.5	16.750	12.0	8.500
	—	150	—	—	—	10.5	
	—	200	—	—	—	13.2	

*Maximum sheave width - 2 (N-W)-¹/₄". **Maximum sheave width = N-W.

For sheave ratios greater than 8:1, or with a center-to-center distance less than the diameter of the large sheave contact the TIC [Customer Support Center](https://www.toshiba.com/tic/). Mount sheaves close to the shaft shoulder.

For motors above 445T frame with narrow V-belts:

$$\text{Sheave Diameter (inches)} = 25 (H/N_R)^{1/3}$$

Where:

H = Rated motor HP

N_R = Rated motor speed in RPM

Maximum sheave width = N-W of shaft. Contact the TIC for other sizes.

$$\text{Belt Speed (Ft/min)} = (\text{Shaft RPM} \times 3.14 \times \text{Sheave Diameter})/12.$$

Figure 4. Shaft Extension Loads Due to Transmission of Power.

Note: Contact TIC for other frames.

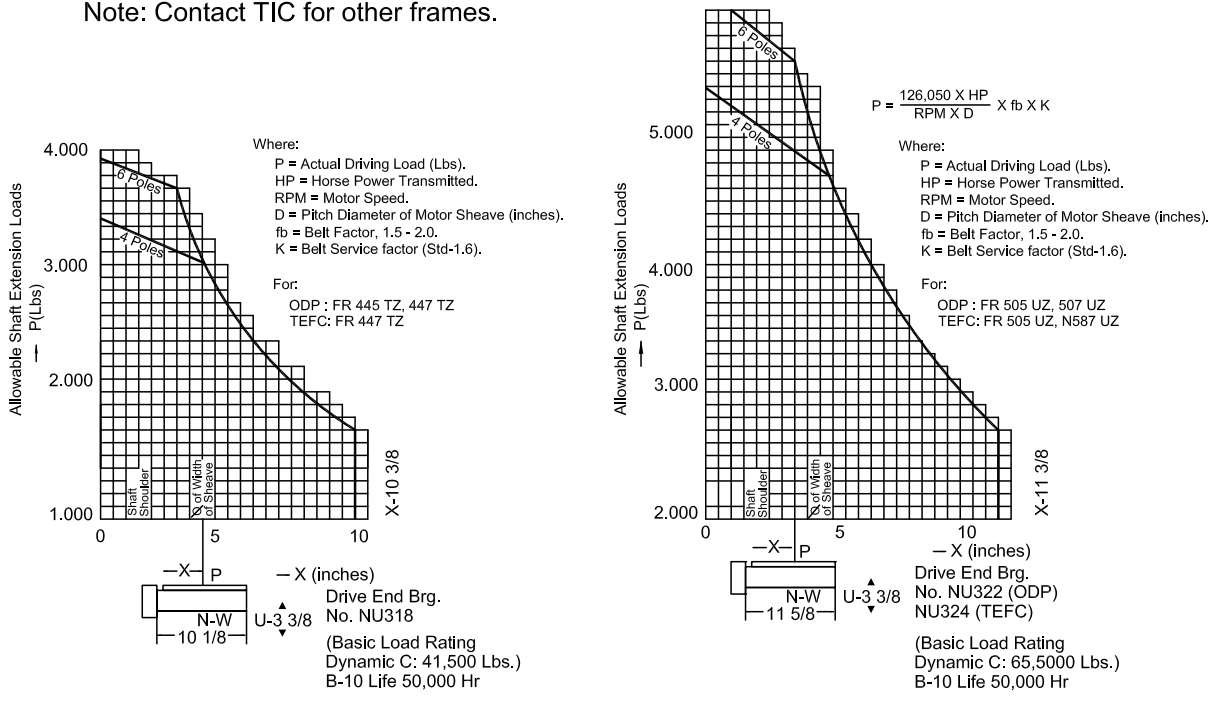

Motor Operation

Motor Start-Up Precheck

Operation Precaution

Any motor operated using an Adjustable Speed Drive is subject to potential premature bearing failures due to the increased shaft currents caused by common mode voltages inherent with operation on a sinusoidal power source. TIC recommends insulating both bearings on frame sizes 444 and larger. Smaller motors are at risk as well and should be considered after review of the application and installation. The user is responsible for protecting the couplings and driven equipment from shaft currents from the motor. Insulated couplings are recommended. Shaft grounding devices provide additional protection, but cannot be used in hazardous areas because of electrical arcing.

Motor Precheck

Perform the following checks before the initial start up.

- Inspect the motor for foreign materials and general cleanliness.
- Ensure that the motor is dry — particularly on the first start and after the machine has stood idle for an extended period.
- Ensure that all drain and fill plugs/caps are secured.
- Ensure that all gaskets are in place and all bolts/screws are secured.
- Ensure that the oil level and/or grease quantity is correct.
- Use a megohmmeter to determine the condition of the windings and insulation (e.g., moisture present, winding shorts, etc.).
- Check all connections to the motor and ensure that the proper phase connections are applied and are secured.
- Ensure that all auxiliary connections are secured.
- Turn off space heaters during motor operation.

- Ensure that the applied input voltage and frequency is within $\pm 10\%$ and $\pm 5\%$, respectively, of the nameplated voltage and frequency.
- Check the alignment of the motor and coupled load such that the shaft and bearings of the motor will not be subjected to unnecessary strain or wear.
- If possible, ensure that the rotor turns freely.
- Ensure that there are no obstructions or interferences to motor operation.



- **DO NOT** turn the rotor by inching (short thrusts at reduced power).
- Avoid touching the hot surfaces of the electric motor without wearing proper protection.
- Keep the terminal box cover in place and secured while the motor circuits are powered.
- Hearing protection is required around noise levels exceeding 80 dBA.

Ensure that all personnel are clear of the motor and the driven equipment during the following test.

Motor Testing

- Run the motor without a load to confirm direction of rotation and basic functionality. Motors with unidirectional blowers can be operated only in the direction shown on the rotation plate attached to the motor.

If the opposite direction is required for a 3-phase motor, switch any two of the 3-phase input lines or contact the Toshiba [Customer Support Center](#) for support.

Note: The certified motor outline will define the motor direction.

- Run the motor for approximately one hour to check for any unusual heating of bearings or windings. This also permits lubrication warm-up before torque is applied to rotating parts.

Run the motor under a load. Check the bearing housing occasionally while running. Using the proper protective gear and/or measuring device, ensure that bearing overheating does not occur.

Maintenance

Routine cleaning, lubrication, and inspections are required components of preventive maintenance. Proper maintenance results in extended mean-time between failures and greatly reduced repairs.

It is also important to create and retain maintenance records. These records serve as a guide to preventive maintenance and provide an indication of what spare parts should be stocked to prevent lengthy motor outages.

The frequency of routine checks will depend on several variables. A few of the primary operational considerations are:

- Cleanliness,
- Insulation resistance,
- Lubrication and bearings, and
- Environmental factors such as excessive moisture, dust, etc.

Cleanliness

Dirt, dust, and oil are the greatest enemies of electrical equipment. When dirt or dust settles on a machine it may prevent heat dissipation and restrict ventilating passages. This may lead to overheating and insulation breakdown. Some types of dust are electrically conductive and may also cause insulation breakdown.

Dust and dirt may be removed from electrical equipment with dry compressed air, dry cloths, or by brushing. The compressed air must be dry and at a low pressure (less than 25 psi) as not to damage the insulation. Grit, iron and copper dust, graphite, and lamp black should be removed by suction. Hose tips for either pressure or suction should not be metal.

Dust and dirt also have a harmful effect in that they tend to absorb oil or grease. This may result in the formation of gum that is not easily removed.

Oil or grease covered machines should be cleaned thoroughly and have a fresh coating of insulating varnish applied. Most of the oil or grease can be removed with a cloth moistened with an appropriate solvent/cleaner. A brush should be used for surfaces difficult to reach by hand. Use a spray gun

to clean inaccessible slots and passages. After using the solvent, be sure to dry the windings with dry compressed air.

DO NOT use a solvent that has toxic effects or that has a deteriorating affect on varnish.

Insulation Resistance

Moisture may develop in a motor during long-term storage. To determine if there is moisture in the motor, an insulation test may be used. A megohmmeter can be used to measure the insulation resistance which is an indicator of the presence of moisture in the motor.

The insulation resistance is to be measured per IEEE Standard 43.

When comparisons are made between present and previous readings, it is possible to observe the winding insulation trend. When correlating periodic readings, it is desirable to test at a definite voltage and time, and to record other pertinent conditions (e.g., ambient temperature, humidity, etc.).

The recommended minimum insulation resistance in megohms at 40° C (104° F) is equal to the rated motor potential in kilovolts plus one megohm (e.g., a motor with a rating of 460 volts would have a minimum insulation resistance limit of 0.5 + 1 resulting in a 1.5 megohms minimum).

Recommended Practice for Drying

Drying the motor will be required if the insulation resistance value is too low. This may be accomplished by using an external heat source or by circulating direct current through the coils.

Apply External Heat

Place the motor into an enclosure and apply heat from steam pipes or electric strip heaters. The enclosure should have a vent at the top for the evaporated moisture to escape.

This process should be carried out slowly or winding damage could result (see [Figure 5. on pg. 14](#)). Sufficient time should be allowed for the process. At no time should the temperature be allowed to exceed 85° C (185° F).

Figure 5. Insulation Resistance vs. Drying Time.

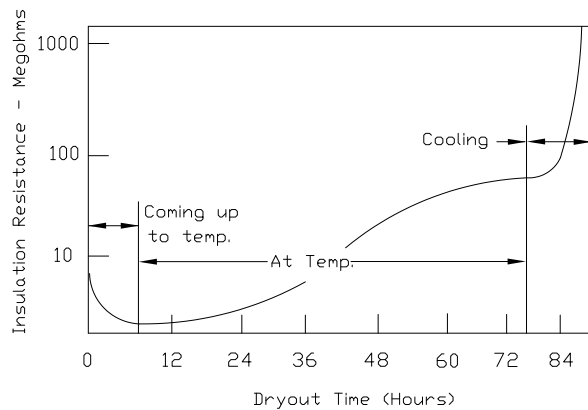

Apply Direct Current

An alternative method of drying the windings requires direct current. Frequently, welding sets are available and can be operated in parallel to obtain the desired current. For suitable drying temperature, the direct current (DC) should be about one-half of the rated alternating current (AC) value specified on the nameplate of the motor.

DO NOT exceed an insulation temperature of 75° C (167° F).

Securely connect the leads from the current transformer and temperature detectors. Current flow and the temperature are to be monitored to protect the motor from damage.

The current **MUST BE LIMITED** so that the maximum temperature of the windings do not exceed 85° C (185° F).

The insulation resistance drops rapidly initially as the winding heats up, then rises slowly as the moisture is driven off, and finally levels off at a steady value. Drying may be concluded when a fairly steady value of insulation resistance is reached.

It is advisable to keep annual records of insulation resistance readings and the conditions (e.g., ambient temperature, humidity, etc.) under which the readings are taken.

Motor Lubrication

Adequate lubrication is required for normal motor operation and to assure a long motor life. Toshiba motors are properly greased at the time of manufacture. Relubrication of electric motors is a critical part of the maintenance program for the motor-driven system.

It is also recommended that motors which have been stored for a period of six months or more be relubricated prior to commissioning.

Lubrication Specifications

A standard hand held grease gun typically delivers 1.25 grams/pump stroke.

Table 2 lists the recommended grease volume for the listed frame sizes.

Table 2. Stored Motor Relubrication Guidelines.

Frame Size	Grease Supply
143-256	2.5 – 3.75 grams
284-405	5 grams
444 and Larger	

Ensure that the grease nipples are clean and free of dirt and contaminants before regreasing. Only use grease that is fresh and free of contamination.

Toshiba motors may be equipped with an automatic grease relief fitting, a grease plug, or a grease outlet cover plate.

The new grease may not fully expel the remaining used grease.

Avoid over greasing — Use the recommended grease volumes.

Note: When relubricating roller bearings the monthly service time is one half.

Grease leakage around the shaft hole of the motor housing could indicate an over-greasing condition. Excess grease should be purged by running the motor temporarily with the relief fitting open.

It may be necessary to remove an automatic grease relief fitting due to hardening of grease. Motors using a grease plate may require that old grease be scraped out once every two years as a minimum.

Standard Service

See Table 4 to select the proper service condition.

See Tables 5 and 6 on pg. 16 for the relubrication schedules of horizontal and vertical motors, respectively.

See Tables 7, 8, and 9 on pg. 16 for the relubrication volume requirements of horizontal and vertical motors, and of vertical motor angular contact bearings, respectively.

Before greasing ensure that fittings are clean and free of dirt and contaminants.

Remove the relief plug or plate and pump the required amount of grease using a low-pressure hand-held grease gun.

Allow the motor to run with the grease outlets open for the specified time periods as indicated in Table 3 before replacing any hardware.

Table 3. Pre-Hardware-Change Run Times.

Frame Size	Recommended Run Time
143T-365T	20 – 30 minutes
405T and larger	60 minutes

Table 4. Service Conditions.

Service Conditions	
Standard Duty	Eight hours per day. Light to normal loading. Clean and dust-free conditions.
Severe Duty	24 hours per day. Light to normal shock loading and/or vibration. Exposure to dirt or dusty conditions.
Very Severe Duty	24 hours per day. High ambient temperature. Normal to high shock loading and/or vibration. Exposure to dusty conditions. Confined mounting conditions. Reduce severe duty interval by 1/3.

Table 5. Horizontal Motor Lubrication Schedule.

Sync. RPM Range	Frame Size	Type of Service	
		Standard Duty	Severe Duty
3600 – 3000 1800 – 750	143 – 256	8 months 30 months	4 months 12 months
3600 – 3000 1800 – 750	284 – 365	8 months 24 months	4 months 12 months
3600 – 3000 1800 – 750	404 – 5811	8 months 18 months	4 months 8 months

Table 6. Vertical Motor Lubrication Schedule.

Sync. RPM Range	Frame Size	Type of Service	
		Standard Duty	Severe Duty
3600 – 3000 1800 – 750	180 – 250	8 months 30 months	4 months 10 months
3600 – 3000 1800 – 750	280 – 360	8 months 24 months	3 months 8 months
3600 – 3000 1800 – 750	400 – N449	4 months 18 months	2 months 6 months

Table 7. Horizontal Motor Bearing Lubrication Volumes.

Frame Size	Bearing Size	Periodic Grease Amount
143 – 256	6205/6206 6207/6208/6305 6306 6308/6309	3 grams 5 grams 10 grams 20 grams
284 – 365	6211 6309 6310/6312 6314	10 grams 20 grams 30 grams 50 grams
404 – 5811	6216 6313/NU313/ NU317 NU318/NU320 6316/6317/6318 6320/6322/6324 NU322/NU324 NU328/NU228	10 grams 20 grams 30 grams 50 grams 80 grams 80 grams 80 grams 100 grams

Table 8. Vertical Motor Bearing Lubrication Volumes.

Frame Size	Bearing Size	Periodic Grease Amount
180 HP	6306	7 grams
210 HP – 280 HP	6308 6309 6310	10 grams 13 grams 15 grams
320 HP – 360 HP	6311 6312	17 grams 20 grams
400 HP – N449 HP	6313 6314 6315 6318	23 grams 26 grams 30 grams 41 grams

Table 9. Vertical Motor Angular Contact Bearing Lubrication Volumes.

Frame Range	Bearing Size	Periodic Grease Amount
180LP	7306B	14 grams
210LP – 280LP	7308B 7309B 7310B	21 grams 25 grams 30 grams
320LP – 360LP	7311B 7312B	10 grams 20 grams 30 grams 50 grams
400LP – N449LP	7313B 7314B 7315B 7318B	46 grams 53 grams 56 grams 82 grams

Recommended Greases



DO NOT mix greases of different brands. This practice may destroy the composition and physical properties of the grease.

In the event that a different grease is required, open the grease outlet and purge the system as much as possible of the existing grease.

Repeat the system purge after one week of service. Consult the Toshiba Customer Support Center for further information on grease type compatibility.

The nameplate of the motor will typically specify the grease to be used with the motor.

Standard 840 and 841 Toshiba motors are greased at the factory using the following lubricant:

Table 10. Factory Grease Type.

Operating Temp. Range -30° C – 50° C (-22° – 122° F)	
Manufacturer	Exxon Mobile Corp.
Grease Name	Mobil Polyrex [®] EM or Equivalent

Recommended Greases for Standard Applications

Table 11. Standard Applications Grease Type.

Operating Temp. Range -30° C – 50° C (-22° – 122° F)	
Grease Name	Manufacturer
Mobile Polyrex [®] EM	Exxon Mobile Corp.
Chevron [®] SRI	Chevron Corp.
Mobile Unirex [®] N 2	Exxon Mobile Corp.
Shell Dolium [®] R	Shell Oil Co.
Mobilith SHC [®] 100	Exxon Mobile Corp.

Unless otherwise specified on the motor nameplate, use the recommended greases for the listed temperature range.

Recommended Greases for Special Applications

The following greases recommended for special applications only and should be used only for motors specifically built for such conditions.

Table 12. Special Applications Grease Type.

Operating Minimum Ambient Temp. -60° C (-76° F).	
Operating Maximum Ambient Temp. 90° C (194° F).	
Grease Name	Manufacturer
Mobile Unirex [®] S2	Exxon Mobile Corp.
Triton [®] 460	Conoco Phillips Co.
Mobilith SHC [®] 460	Exxon Mobile Corp.

Heating of Bearings

Bearings should be periodically checked for excessive heating. This is very important during the run-in period when overheating occurs most frequently. If overheating does occur, immediately determine the cause and take corrective action.

Overheating of Antifriction Bearings

Note: Antifriction bearings are any bearings that contain moving elements to provide a low friction support surface for rotating surfaces.

It is always advisable to make frequent checks on the temperature of the bearings. Total bearing temperature should not exceed 140° C (284° F).

Toshiba standard settings for bearings alarm activation is 100° C (212° F) and trips at 110° C (230° F).

Listed below are the most probable causes of bearings overheating.

- Grease contamination.
- Insufficient amount of grease.
- Too much grease — Causing churning.
- Grease too stiff — Prevents free action in the bearings.
- Excessive thrust due to misalignment or excessive imposed loads.
- Pounding caused by bearings being loose on shaft or balls being worn.

- Actual bearing failure caused by a broken ball, broken cage, or flat balls.
- Heat from an external source causing a high bearing temperature.

Problems due to grease failures are many times due to inferior grease that is not neutral or free of moisture, acid, or non-lubricating fillers. These characteristics cause the grease to turn rancid in a short period of time and may actually etch and roughen the highly polished surface of the bearings. Some grease types also tend to become tacky or gummy and prevent freedom of the ball or roller action.

For performance issues caused by degradation of grease performance, the bearings should be disassembled and thoroughly cleaned with petroleum solvent or flushing oil. The bearing chamber should then be refilled with a new good grade of grease. Be sure that all solvent is removed before filling with grease. Fill the bearing chamber to three-quarters capacity to obtain the best efficiency. See the nameplate of the motor for the correct grease type to be used.

Bearing malfunctions may be caused by a coupling misalignment. **DO NOT** exert pressure on one side of the frame to make it fit into an uneven base or floor. If the frame distortion is excessive, bearing operation will be affected.

Mechanical failures caused by defective bearings should be remedied by replacing the bearings, determining the underlying cause, and taking the steps to avoid a recurrence of the problem. Excessive temperature rise of the bearings may also be reduced by removing the source of external heat if applicable.

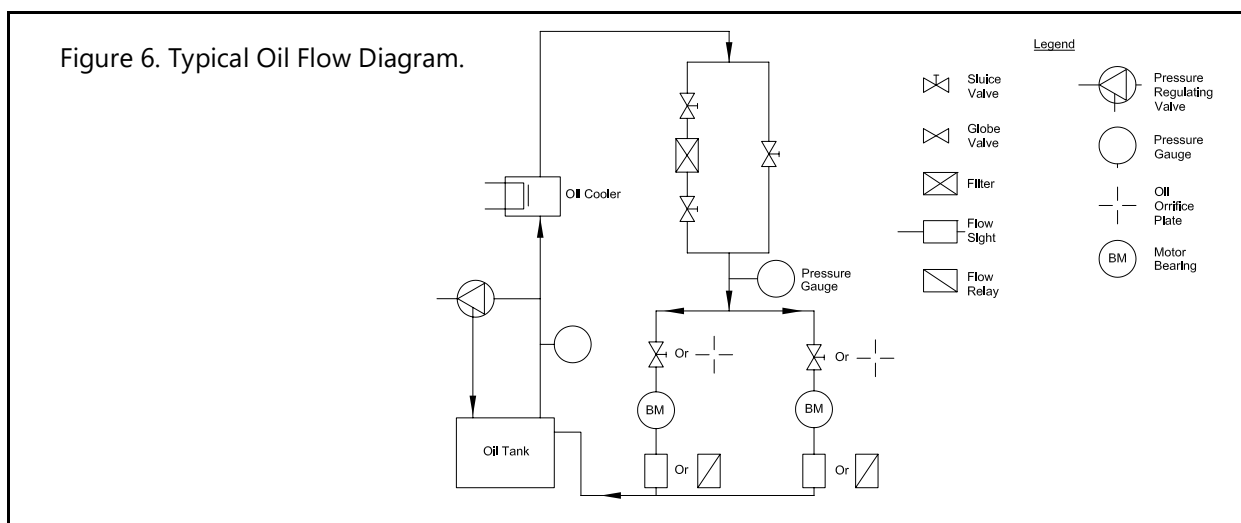

Motor Disassembly and Reassembly

Remove/Replace Bearings

When removing or replacing a bearing set, there are several guidelines that should be adhered to in every case. Following these rules closely will prevent damage to the bearings

and/or motor and will result in a longer bearing life.

Remove the Bearings

When removing the bearings, always use an approved bearing puller. Follow all standard bearing puller instructions and safety procedures (i.e., safety glasses, protective gloves, etc.).

Figure 7. Drive End and Opposite Drive End Bearing Assemblies.

Drive End
Bearing
Assembly

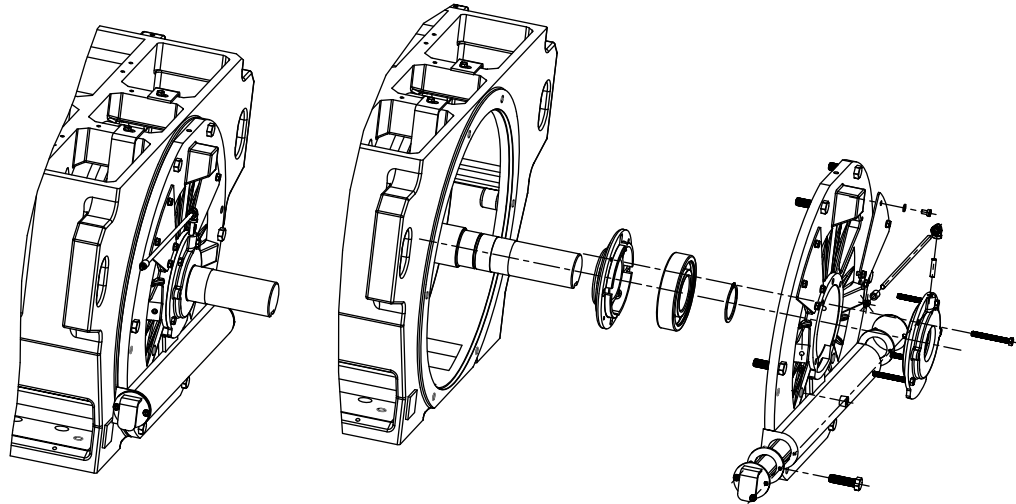

Opposite
Drive End
Bearing
Assembly

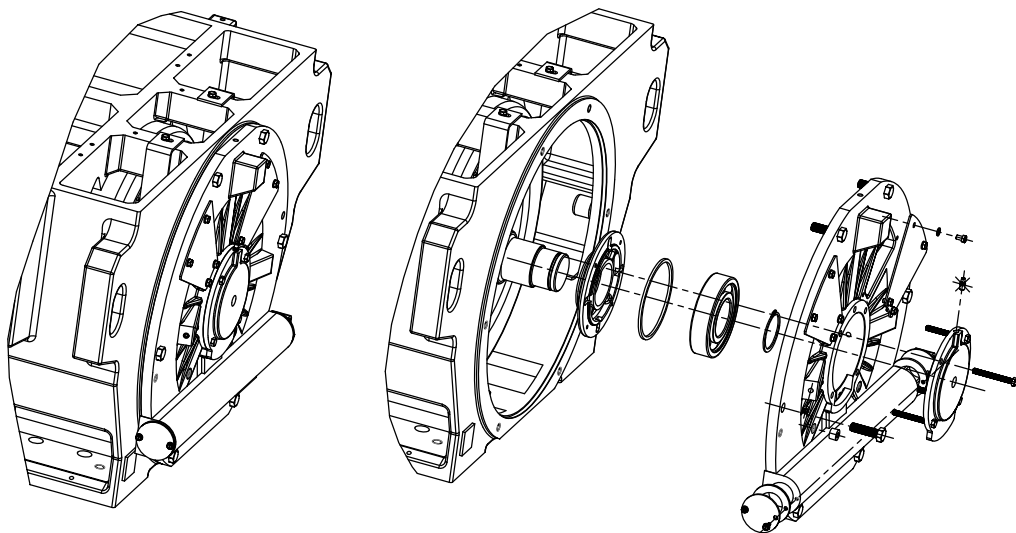

Install the Bearings

Bearing Installation Precautions

- **NEVER** open the protective cover on new bearings — Prevents dust or dirt exposure.
- **DO NOT** remove the bearings from the received package until the moment of installation. **Always** open the package in a clean place.
- **NEVER** clean new bearings — The slushing oil on new bearings should not be removed.
- **DO NOT** pack the bearings to capacity as this will cause overheating (churning). Fill the bearing chamber to three-quarters capacity with clean grease.
- **DO NOT** force the bearings onto a shaft by means of the outer race.
- **DO NOT** attempt to force the bearings onto a badly worn shaft or a shaft that is too large for the bearings.

Installation

Pressing in or induction heating are commonly accepted bearing installation methods.

When pressing in, coat the shaft with a thin film of oil.

Note that the metal tube fits against the inner race of the bearings. **DO NOT** strike the tube very hard — light tapping will suffice.

Induction heating is the process wherein the bearings are heated in an oven or oil bath allowing for it to expand and slide onto the shaft. Before heating, ensure that the inner diameter of the bearings have been checked against the shaft journal dimension to prevent too tight of a fit after the bearings cool. The maximum difference of bore to journal should be 0.0004”

Use a temperature of approximately 121° C (250° F). If the temperature is too high damage to the bearings may result and if the temperature is too low it may cause the bearings to seize onto the shaft.

Figure 8. Bearing Puller.

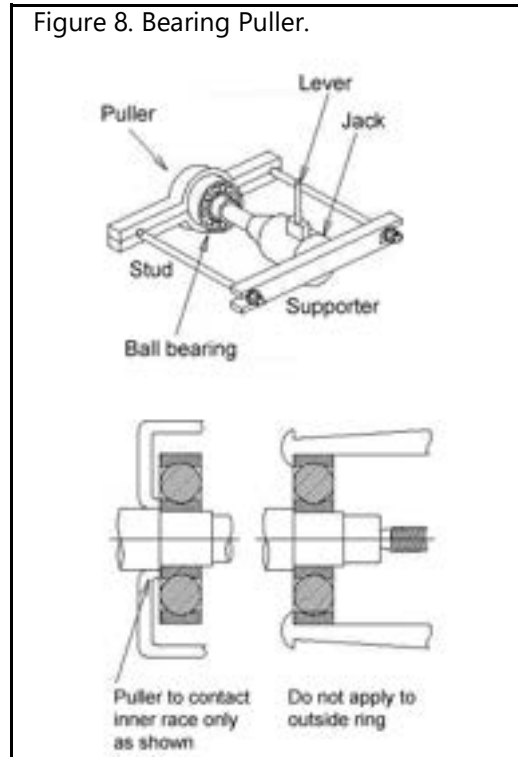

Rotor Removal

CAUTION

The rotor may be pulled out for internal inspection, repair, and cleaning (figure [Figure 9. on pg. 21](#)).

After disassembling the bearing brackets, bearings, and other accessories, the rotor is lifted with chain blocks connected to the shaft ends, shifted along the axial plane, and pulled out of the stator.

Axial space requirements for the rotor removal and reinsertion will be two times the rotor length.

Two or more lifting hooks which can micro-adjust the horizontal shift and height of the rotor are required. Typically, the rotor is lifted by chain blocks hung to the hooks of a traveling crane.

A pipe or extension shaft that is capable of holding the rotor shaft is required to pass the rotor through the stator.

When a pipe is used, it shall be of the material matching the rotor weight and have an inner diameter of 0.2 to 0.78” (5.08 to 19.8 mm) larger than the mating shaft diameter.

Wind a protective sheet around the rotor shaft at the contact point to a length of at least twice the pipe diameter. The shaft may then be inserted into the pipe.

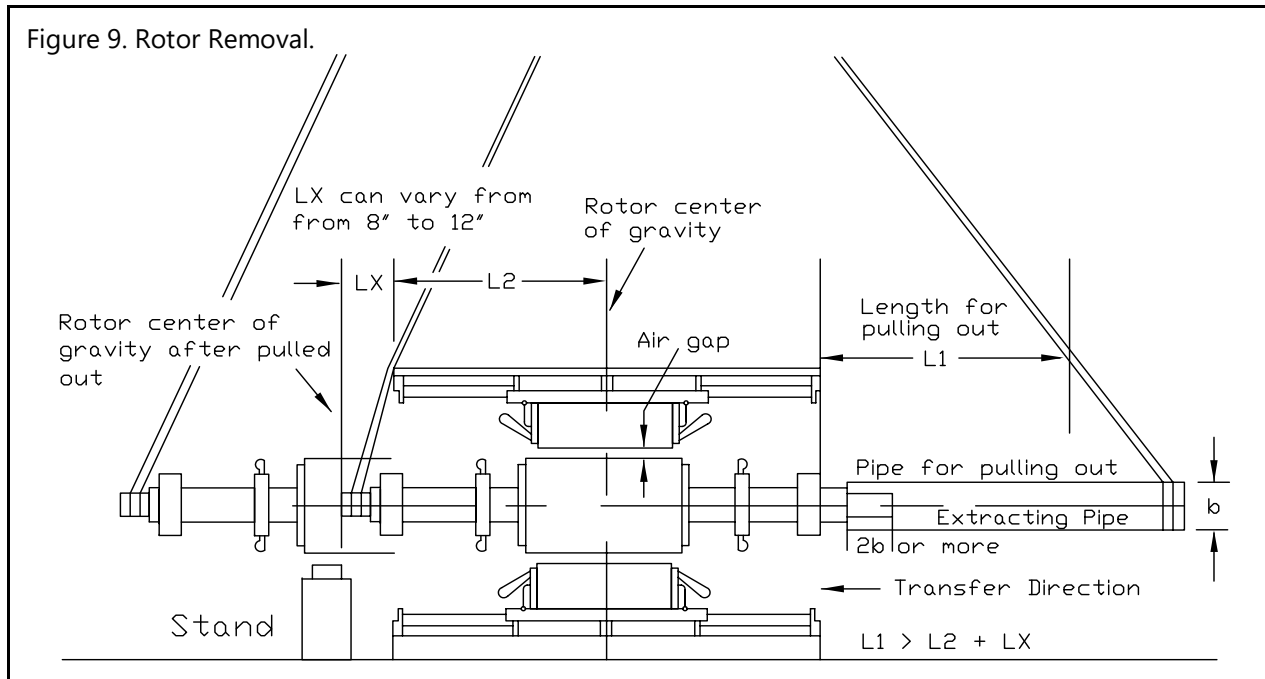

Lifting the Rotor

1. Insert the extracting pipe.
2. Wind the protective sheet around the contact portion of the shaft.
3. Insert the pipe to a depth of at least twice the diameter of the pipe.
4. Slowly lift the rotor through the chain block, paying close attention to the rotor-to-stator air gap.

Removing the Rotor

Ensure that the rotor does not contact the stator throughout the operation.

Slowly shift the rotor along its axial plane. When the center of gravity of the rotor exits the stator, rest the rotor on the stand. Pull-out is completed.

Inserting the Rotor

The insertion is made by the reverse order of pull-out.

Completion of the insertion phase occurs when the difference between the core ends of the stator and rotor are equal at both ends.

Electrical Testing

Power Supply

Nameplate voltage and frequency should be consistent with the power supply. The motor will operate satisfactorily on line voltages within 10% of the nameplate value and a frequency within 5% of the nameplate value.

The combined variation shall not exceed 10%. A motor that is rated for 230 volts can be operated on 208-volt network systems per the nameplated amps, but with slightly modified performance characteristics.

Dual voltage and single voltage motors can be connected for the desired voltage by following the connection diagram shown on the nameplate. Alternate starting connections are shown in the conduit box of the motor.

Explosion Proof motors have temperature limiting devices in the motor enclosure to prevent an excessive external surface temperature of the motor in accordance with UL standards. The P1 and P2 terminals of the thermal protectors should be connected to the motor control equipment. These are bi-metal thermostats that are used for the primary thermal protection. Optional auxiliary thermistors embedded in the winding can only be used as secondary devices for thermal protection. The leads will be labeled TP1 and TP2 for thermistors. All supplementary device leads will be extended through the main terminal box.

Wiring of the motor and control, overload protection, and grounding should be in accordance with the National Electrical Code and local building codes. Explosion Proof motors have the internal terminal grounding connection inside of the main terminal box which must be used for the equipment grounding connection. An optional external grounding terminal on the feet is for a supplemental bonding connection, where local codes permit or require such a connection.

Lock out/Tag out and disconnect the motor from the power supply before opening the conduit box or performing any maintenance or repair on the motor.

Before applying power to the motor, use a megohmmeter to test the insulation resistance of the windings. A minimum of 10 megohms is

recommended (see the section titled [Motor Precheck on pg. 12](#)).

Motor Terminals and Connectivity

Match the nameplate rating of the motor, connection diagram, and lead numbers with the appropriate category for the applicable connection requirement. Toshiba special built or special rated motors may follow different connections. If more information is required, contact the TIC [Customer Support Center](#) with the nameplate model number and serial number of the motor for connection information.

EQP GLOBAL motors in frames 143T – 184T and all other Toshiba motors rated 0.5 HP – 5 HP are Wye-connected motors. All other standard size Toshiba motors are Delta-connected.

The equivalent lead wire markings per NEMA(IEC) are: T1(U1), T2(V1), T3(W1), T4(U2), T5(V2), T6(W2), T7(U5), T8(V5), T9(W5), T10(U6) T11(V6), T12(W6).

Field Insulation Test

Field insulation tests on large motors are performed to determine the following:

- The condition of the insulation.
- The need to recondition insulation system to prolong the life of the motor.
- A long-range program to detect progressive deterioration.

Because the motor may be commissioned within a wide range of environments and applications, this section will discuss installation variables and other systemic considerations that apply with each installation.

Each installation must be evaluated for the specific conditions of the application to determine the test method that is best suited for the application.

The insulation resistance test is made with DC rather than AC to determine if a system can be tested with high voltage. For 0 – 7000 volt form-wound induction motors, the tests in [Table 13 on page 23](#) are recommended.

Table 13. Recommended Insulation Tests.

Type of Winding	Voltage Range	Type of Test					
		AC Hipot		DC Ohmmeter		DC Hipot	
		Pre Service	In Service	Pre Service	In Service	Pre Service	In Service
Form	0 – 600	Yes	Yes	Yes	Yes	No	No
	601 – 7000	Yes	No	No	No	Yes	Yes

Effect of Altitude on Temperature Rise

Because most motors are cooled by convection and because the density and corresponding cooling ability of the air decreases with altitude, allowances must be made for operation in altitudes above 3300 feet (1.0 km).

NEMA Standards specify that the temperature rise as tested at low altitudes shall be less than that tabulated in the Temperature Rise Standard by 1% of the specified temperature rise for each 330 feet (0.1 km) increase in altitude above 3300 feet.

As an illustration, an open motor tested at sea level must have a full load temperature rise of only 64° C (147° F) to be suitable for operation at 9900 feet altitude with the standard temperature rise of 80° C (176° F).

The calculations are shown below:

Standard Temperature Rise Open Motor = 80° C
 Allowance for 9900 Feet Altitude
 Maximum Permissible Temperature Rise at Low Altitude is 64° C (80° C - 16° C).

$$\frac{9900 - 3300}{330 * 100} * 80^{\circ}C = 16^{\circ}C$$

Special Equipment (Accessories)

Some of the following special equipment or accessories may be required as a function of several variables including motor size, ambient operating conditions such as moisture, dust, temperature, etc.

Space Heaters

Space heaters are provided in electrical motors that operate under damp, cold, humid, or environmentally exposed conditions.

To counteract dampness, heaters are designed to maintain the internal temperature of the motor at approximately 5° C (41° F) above the ambient temperature.

Heaters may be specially designed to keep lubricants from becoming excessively cold. Operating temperatures may be controlled to meet various requirements.

The location of the space heaters in the machine is dependent on the use for which they are provided. Typically, the heaters are mounted on one or both of the bearing arms, the frame, or coil guards.

Where heaters are to be used, some consideration should be given to the installation position as it applies to the disassembly of the equipment (when required).

Do not operate the space heaters while the motor is running.

Stator Temperature Detectors

Many large motors are equipped with temperature detectors to detect the stator winding temperature. The type of detector used is based solely on the customer requirements. The leads are brought out to a separate auxiliary terminal box.

Several types of temperature detectors are available for sensing stator winding temperature.

Resistance Temperature Detectors

A Resistance Temperature Detector (RTD) is a variable resistor in which the resistance value of the component varies as a function of an ambient thermal condition. The resistance variation is used to indicate changes in temperature. The RTDs are installed in the motor slots.

Thermocouple

Thermocouples are comprised of the connection between two dissimilar metals that produce a voltage when heated. This voltage is calibrated and used to indicate the ambient motor temperature.

Thermocouples are installed in the motor slots. The thermocouples are designed to operate in conjunction with instruments that measure the varying voltage across the bi-metal junction.

Bearing Temperature Detectors

Many sleeve bearing motors are supplied with some type of bearing temperature detector. These devices will provide a warning and/or shut down the equipment if the bearings overheat. The overheat may be caused by any one or more of several possible conditions (e.g., misalignment, loss of lubrication, bearing failure, etc.).

Bearing temperature detectors are available in several varieties. Typical detectors are resistance-temperature detectors, thermocouples, thermistors, bulbs filled with expandable liquids, bimetallic elements, etc. Each of these detector types require some form of switching equipment to process the signal from the device.

Air Filters

Air filters on motors are designed to trap air borne dirt before it gets into the working parts of a motor. The usefulness of filters is dependent upon the operating environment and how frequently they are cleaned and/or changed.

The air filter types are listed below.

- **Metallic Air Filters**

These are permanent, cleanable, viscous-type filters made of galvanized metal construction. Stainless steel and Monel construction are also available. It is constructed of horizontal layers of galvanized wire screen mesh (so arranged as to provide a large filtering area) and has no direct passages through the filter media.

- **Non-Metallic Filters**

These are washable, replaceable filters of foam with a metallic frame for support.

- **Dry Type Filters**

These are non-reusable filters composed of a fiberglass material on a round wire frame.

All motors are designed to operate properly with or without air filters. However, air filters do tend to restrict and reduce the volume of air that cools the motor. To ensure that the motor does not reach a critical temperature, stator winding protection devices are recommended.

Ordering Information and Spare Parts

Ordering Information

Toshiba motors may be ordered using the part naming convention listed in the Motors, Drives, Controls, & PLCs Catalog 2019.

The catalog may be found at the Toshiba.com\tic\ website.

From the home page, click Products/Low Voltage Motors/*Motors, Drives, Controls, & PLCs Catalog 2019*.

Spare Parts Listing

Listed in Table 14 are wear items and are typically the most susceptible to damage. The table should be considered as a guide only, but it will offer reasonable security for normal operations.

Stock size will depend on the application. Critical applications where continuous operation is of importance or if operating in an extreme environment, a larger supply of parts will be required.

Each installation will have to be evaluated for the proper requirements in this respect.

Our complete spare parts catalog may be found at the following web site:

<https://www.toshiba.com/tic/motors-drives/low-voltage-motors>.

Scroll down to the Resources group. Click Spare Parts Catalog.

The spare parts catalog will provide a more expansive listing of the available spare parts for your motor.

Table 14. Recommended Spare Parts for AC Motors.

Item	Part Name	1 to 4 Motors	5 to 9 Motors	10 to 25 Motors
1	DE Bearings (AF)	1	2	2
2	NDE Bearings (AF)	1	2	2
3	Oil Rings (where required)	1 Set	1 Set	2 Sets
4	Sleeve Bearing Liners	1 Set	1 Set	2 Sets

Disposal

Toshiba motors are designed and constructed for error-free operation for years under the most demanding operating conditions.

However, the motor may be damaged by inadvertent mechanical contact, an unprotected lengthy storage in a harsh environment, or operating under a condition for which it was not designed and must be replaced.

Disposal of electrical equipment is never to be carried out via incineration.

Because the motor is constructed almost entirely of metal, it can be recycled.

To disposition a motor that has reached the end of its service life, contact your local recycling center for the proper recycling/disposal methods for electrical equipment within your region.

Service Guide

The following table lists operational symptoms that may occur, probable causes, and the suggested approaches to a solution. This table is intended as

both a diagnostic aid and a quick reference guide. If the source of the malfunction is unknown, or the solution is not achieved after using this information, report the matter to the Toshiba [Customer Support Center](#).

Troubleshooting Assistance		
Symptom	Probable Cause	Remedy
Failure to start	<ul style="list-style-type: none"> Loose, unattached, or incorrectly fastened electrical connections. Low line voltage. Excessive load. Open circuit in stator windings or in squirrel cage bars. Short circuit in rotor or stator. 	<ul style="list-style-type: none"> Confirm as correct and tighten all mechanical and electrical connections. Check panel meters. Reduce load. Remove load/retest. Run a continuity check. Check condition of coils and bars. Repair if possible. If impractical, order renewal parts from the Toshiba Customer Support Center.
Motor overheating	<ul style="list-style-type: none"> Overloaded. Improper line voltage or incorrect frequency. Ventilation obstructed. Unbalanced electrical power. Excessive heat, humidity, dirt, etc., has adversely affected insulation. Motor improperly shimmed; housing and bearings are mechanically stressed. 	<ul style="list-style-type: none"> Reduce load. Clean motor. Check voltage of each phase. Check for failing bearings. Check for Motor/load misalignment. Check insulation resistance check with a megohmmeter. Check for proper shim installations at each foot of the motor.
Noisy or overheating bearings	<ul style="list-style-type: none"> Misalignment between motor and driven machine. Excessive, low, or improperly packed grease (if grease lubed). Low oil level (if oil lubed). Improper fit of bearings or in Babbitt liners (especially in oil grooves). Excessive belt tension or excessive load side thrust. Contaminated oil. 	<ul style="list-style-type: none"> Check alignment and correct as necessary. Clean bearings and repack with proper viscosity grease. Check for damage. Drain and fill to correct level with correct viscosity. Check for scoring of bearing surfaces. Replace bearings if damaged. Reduce belt tension or load side thrust. Check alignment and correct as necessary. Drain oil, flush clean, and refill with recommended oil.

Troubleshooting Assistance		
Symptom	Probable Cause	Remedy
Abnormal noise or abnormal vibration	<ul style="list-style-type: none"> • Foreign matter between fan and another object. • Single-phase operation. • Unbalanced electrical power. • Air gap is unequal. • Loose coupling between motor and the driven equipment. • Loose motor and/or driven equipment. 	<ul style="list-style-type: none"> • Check fan path for obstruction. • Remove foreign object — Keep surroundings free of foreign objects. • Check for unbalanced voltage. • Align the rotor to the center of the stator. • Check and/or replace bearings. • Ensure that mounting bolts are secured.
Vibration	<ul style="list-style-type: none"> • Improper alignment between motor and driven machine. • Loose or incorrect base attachment. • Worn bearings. • Unbalanced load. • Warped base. 	<ul style="list-style-type: none"> • Measure vibration amount with vibration sensor at sides of frame and bearings at shaft height. Determine if the source is in the motor or in the driven machine. • Measure around concentric periphery of coupling with both clamps and dial gage, or with feeler gage and straight edge. Realign if required. Check vertical with a bubble scale or plumb bob. • Check coupling and make adjustments as required. • Remove the load and run the motor to determine if the load is unbalanced. • Check for worn drive gears of the driven machine.
Improper direction	<ul style="list-style-type: none"> • Improper 3-phase input power connections. 	<ul style="list-style-type: none"> • Reverse any two of the 3-phase power leads to the motor and observe the direction of rotation. Refer to connection plate, connection drawing, or the certified motor outline.
Poor or intermittent overall performance	<ul style="list-style-type: none"> • Improper grounding. 	<ul style="list-style-type: none"> • Ensure that all grounds are secured. • Add a ground strap.

Index

50 & 60 Hz Motor Install/Op Manual

A

Accessories, 24
Air Filters, 24

B

Balancing Direct-Coupled Motors, 8
Bearing Temperature Detectors, 24
Bedplate Installation and Leveling, 6

C

Cleanliness, 13
Customer Support, 2

D

Drying, 13

E

Electrical Testing, 22
Equipment Warning Labels, 1, 2

G

General Safety Information, 1
Grouting, 7

H

Heating of Bearing, 18

I

Important Notice, 1
Insulation Resistance, 13

M

Maintenance, 13
Motor Disassembly, 19
Motor Installation, 4
Motor Reassembly, 19

O

Ordering Information, 25
Overheating of Antifriction Bearings, 18

Q

Qualified Personnel, 2

R

Recommended Practice for Drying, 13
Rotor Removal, 20, 21

S

Safety Alert Symbol, 1
Service Guide, 26
Signal Words, 1
Space Heaters, 24
Spare Parts, 25
Spare Parts Listing, 25
Special Equipment, 24
Special Symbols, 1
Start-Up Precheck, 12

T

Temperature Detectors, 24
Testing, 12
Troubleshooting Assist, 26
Troubleshooting Chart, 26

V

Vibration, 9

© 2020
Toshiba International Corporation
Motors & Drives
13131 West Little York Road
Houston, Texas 77041 USA
Tel +713-466-0277
US 1-800-231-1412



TOSHIBA MOTORS & DRIVES
Adjustable Speed Drives • Motors • Motor Controls

www.toshiba.com/tic

TOSHIBA
TOSHIBA INTERNATIONAL CORPORATION