

PRODUCT INFORMATION PACKET

Model No: 256TTFL16042

Catalog No: U354A

Close-Coupled Pump Motor, 20 HP, 3 Ph, 60 Hz, 230/460 V, 1800 RPM, 256JM Frame, TEFC



Regal and are trademarks of Regal Rexnord Corporation or one of its affiliated companies.
©2022 Regal Rexnord Corporation, All Rights Reserved. MC017097E

Nameplate Specifications

Output HP	20 Hp	Output KW	14.9 kW
Frequency	60 Hz	Voltage	230/460 V
Current	48.0/24.1 A	Speed	1775 rpm
Service Factor	1.15	Phase	3
Efficiency	93 %	Power Factor	84
Duty	Continuous	Insulation Class	F
Design Code	B	KVA Code	G
Frame	256JM	Enclosure	Totally Enclosed Fan Cooled
Thermal Protection	No Protection	Ambient Temperature	40 °C
Drive End Bearing Size	6309	Opp Drive End Bearing Size	6208
UL	Recognized	CSA	Y
CE	Y	IP Code	43
Number of Speeds	1		

Technical Specifications

Electrical Type	Squirrel Cage Induction Run	Starting Method	Across The Line
Poles	4	Rotation	Reversible
Resistance Main	.474 Ohms	Mounting	Rigid Base
Motor Orientation	Horizontal	Drive End Bearing	Ball
Opp Drive End Bearing	Ball	Frame Material	Aluminum
Shaft Type	JM	Overall Length	27.27 in
Frame Length	13.75 in	Shaft Diameter	1.750 in
Shaft Extension	5.25 in	Assembly/Box Mounting	F1/F2 CAPABLE
Outline Drawing	B-SS321151-1375	Connection Drawing	A-EE7308

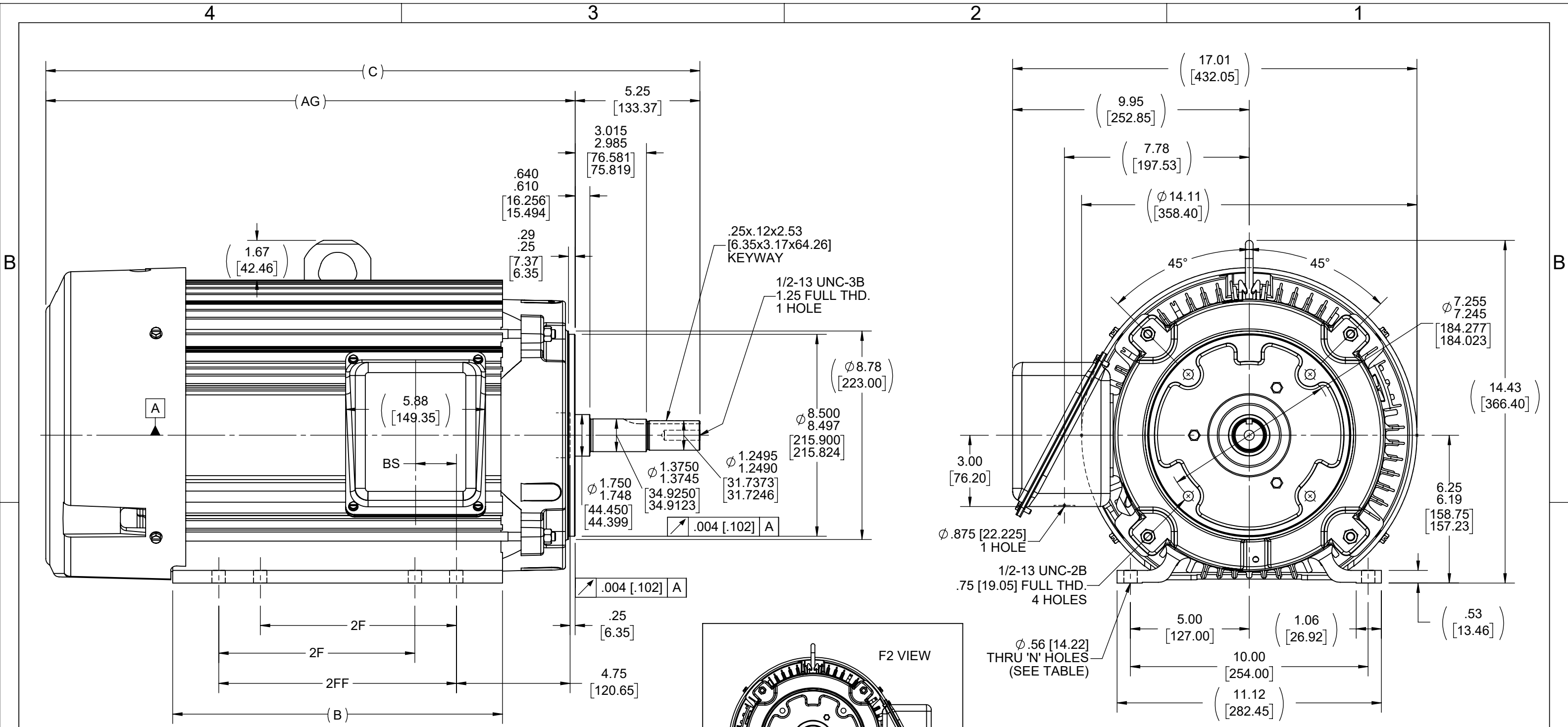

- NOTES:
 1. CONDUIT BOX CAN BE ROTATED IN 90° STEPS.
 2. CONDUIT BOX CAN BE MOUNTED ON OPPOSITE SIDE BY REMOVING BRACKETS AND TURNING FRAME 180°.
 3. NAMEPLATES READ FROM CONDUIT BOX SIDE OF MOTOR.

1200	254JM	25.78 [654.70]	20.53 [521.34]	12.13 [308.10]	---	8.25 [209.55]	1.73 [43.94]	4
1375	254/256JM	27.53 [699.15]	22.76 [565.79]	13.88 [352.55]	8.25 [209.55]	10.00 [254.00]	1.73 [43.94]	8
DASH	FRAME	C	AG	B	2F	2FF	BS	N

DRAWING REVISION E	REVISION BY SP	DATE 05-26-2021
ECO CR-0001205	APPROVED BY AS	DATE 05-26-2021
ECO DESCRIPTION REPLACED FAN GAURD 3C223-E3 TO 205016B		
<small>COPYRIGHT REGAL BELOIT AMERICA, INC. ALL RIGHTS RESERVED PROPRIETARY AND CONFIDENTIAL INFORMATION - THIS DOCUMENT IS THE PROPERTY OF REGAL BELOIT AMERICA, INC. ("OWNER") AND CONTAINS OWNER'S PROPRIETARY INFORMATION. ANY PERSON, CORPORATION OR OTHER FIRM RECEIVING IT IS DEEMED, BY RECEIVING IT, TO AGREE THAT IT, AND/OR ANY PART OF IT, SHALL NOT BE DISCLOSED TO ANY PERSON, CORPORATION OR OTHER ENTITY, DUPLICATED, AND/OR USED, EXCEPT AS EXPRESSLY APPROVED IN WRITING IN ADVANCE BY OWNER. THIS DOCUMENT SHALL BE RETURNED TO OWNER UPON REQUEST. IT MAY BE SUBJECT TO CERTAIN RESTRICTIONS UNDER APPLICABLE EXPORT CONTROL LAWS AND REGULATIONS.</small>		

TOLERANCES UNLESS OTHERWISE SPECIFIED:
 DEC. INCH mm ANGLE
 .X ±0.1 [±2.5] ±7° 30"
 .XX ±0.03 [±0.76]
 .XXX ±0.005 [±0.127]
 .XXXX ±0.0005 [±0.0127]
 REMOVE BURRS & BREAK SHARP EDGES: .003/.015 [0.076/.381] X 45°
 CORNER FILLETS: R.02 [51]
 MACHINED SURFACES: 200 INCH mm 5.1
 mm SHOWN IN [BRACKETS]

DRAWN BY
RWR
DATE
07-10-2007
APPROVED BY
ML
DATE
07-11-2007
REFERENCE
THIRD ANGLE PROJECTION

REGAL™ Regal Beloit America, Inc.
 DESCRIPTION
OUTLINE
 250 JM FR. - TEFC - ALUMINUM FRAME
 MATERIAL PROCESS/FINISH
 SIZE DRAWING NUMBER SHEET
B SS321151 1 OF 1

EE7308

THREE PHASE
DUAL VOLTAGE MOTOR



VIEW OF TERMINAL END

REF.
WINDING DIAGRAM

T8Y, T2Y, T2BL, T4BX, T2EC, T2G
T6BZ, T2B, T6BL, T4AV, T6B, T4B

OPTIONAL CORD
CONNECTION

L1 — WHITE
L2 — RED
L3 — BLACK

NO.	REVISION	BY & DATE	CHK	ANG	TOLERANCES UNLESS SPECIFIED		FINISH	DRAWN RM 11/20/1990				
					DEC.	INCHES						
5	CHG TO REGAL LOGO	SL 09/10/2015	AB					CHK ML 11/21/1990				
4	REVISED IEC NOTATIONS	MSG 11/15/2011	CMN	.X	±.1			APPD SAS 04/24/2003				
3	ADDED IEC NOTATIONS... (U1), (V1) ETC. MU95194	MSG 5/10/2010	MJS	.XX	±.02		TITLE CONNECTION DIAGRAM	SCALE 1=1				
2	ADDED THE OPTIONAL CORD CONNECTION MU46318	RDH 04/24/2003	DRS	.XXX	±.005		3Ø - DUAL VOLTAGE MOTOR	REF				
1	REDRAWN	RM 11/20/1990		.XXXX	±.0005		MAT'L.	FMF				
					±7'30"			PREV				
THIS DRAWING IN DESIGN AND DETAIL IS OUR PROPERTY AND MUST NOT BE USED EXCEPT IN CONNECTION WITH OUR WORK ALL RIGHTS OF DESIGN AND INVENTION ARE RESERVED THIS IS AN ELECTRONICALLY GENERATED DOCUMENT - DO NOT SCALE THIS PRINT							RFP	CAD FILE ee7308	SIZE A	DRAWING NO. EE7308	PAGE OF 5	REV. 5
							DIST WP					



Regal Beloit America, Inc.



P.O. BOX 8003
 WAUSAU, WI 54401-8003
 PH. 715-675-3311

DATA VOLTS: 460

CERTIFICATION DATA SHEET

CUSTOMER: _____ CUSTOMER P.O. #: _____
 ORDER #: _____ REFERENCE MODEL #: 256TTFL16042
 CONN. DIAGRAM: A-EE7308 CAT #: U354A
 OUTLINE: B-SS321151-1375 CUSTOMER PART #: _____
 WINDING: K2564164 R26 6 MOUNTING: F1/F2 CAPABLE
 SPEED: _____

TYPICAL MOTOR PERFORMANCE DATA

HP	KW	SYNC RPM	FL RPM	FRAME	ENCLOSURE	TYPE	KVA CODE	DESIGN
20	14.9	1800	1775	256JM	TEFC	TFY	G	B

PH	HZ	VOLTS	AMPS	START TYPE	DUTY	INSL	S.F.	AMB	ELEV.
3	60/50	230/460#190/380	48/24.1&44/22	ACROSS THE LINE	CONT	F	1.15	40	3300

F.L. EFF	93.0	3/4 LD EFF	93.6	1/2 LD EFF	93.0	GTD EFF	ELECT. TYPE
F.L. PF	84.0	3/4 LD PF	81.0	1/2 LD PF	72.0	92.4	SQ CAGE IND RUN

F.L. TORQUE	LR AMPS @ 460 V	L.R. TORQUE	B.D. TORQUE	F.L. RISE (°C)
59.2 LB-FT	138	104 LB-FT 176%	146 LB-FT 247%	65

@ 3 FT.	POWER	ROTOR WK²	MAX. LOAD WK²	SAFE STALL TIME	STARTS/HOUR	MOTOR WGT
65 dBA	74 dBA	3.2 LB-FT²	125 LB-FT²	25 SEC.	2	425 LB.

*** SUPPLEMENTAL INFORMATION ***

DE BRACKET TYPE	ODE BRACKET TYPE	MOUNT TYPE	MOTOR ORIENTATION	SEVERE DUTY	HAZARDOUS LOCATION	DRIP COVER	SCREENS	PAINT
C-FACE	STANDARD	RIGID	HORIZONTAL	NO	NONE	NO	NONE	BLUE (ENAMEL)

BEARINGS		GREASE	SHAFT TYPE	SPECIAL DE	SPECIAL ODE	SHAFT MATERIAL	FRAME MATERIAL
DE	ODE	POLYREX EM	JM	NONE	NONE	1045 HOT ROLLED (C-204)	ALUMINUM
BALL	BALL						
6309	6208						

THERMOSTATS	PROTECTORS	WDG RTD's	BRG RTD's	THERMISTORS	CONTROL	SPACE HEATERS
NONE	NOT	NONE	NONE	NONE	FALSE	NA

R1 (ohms/ph)	R2 (ohms/ph)	X1 (ohms/ph)	X2 (ohms/ph)	Xm (ohms/ph)	VIBRATION (in/sec)	FLOAT
0.267	0.207	0.99	1.491	28.4	0.150	ODE

* N O T E S *	INVERTER TORQUE: NONE INV. HP SPEED RANGE: NONE					
	ENCODER: NONE NONE NONE					
	BRAKE: NONE NONE NONE					
	FT-LB: NA VOLTAGE: NONE HZ:					
	UL: V-INS, CONST UL REC					

PREPARED BY: FAREEDA DUDEKULA
 DATE: 9/17/2018

Data Sheet

Date: 12/10/2018
 Customer: _____
 Attention: _____
 Submitted by: FAREEDA DUDEKULA



256TTL16042

Submittal

Data @ 460 V

Motor Load Data

Load	0%	25%	50%	75%	100%	115%	125%	LR
Current (Amps)	8.5	10.5	14.0	18.5	24.1	27.0	30.0	138
Torque (ft-lb)	0.00	14.5	29.5	44.5	59.2	68.0	74.5	104
RPM	1800	1795	1785	1780	1775	1,770	1760	0
Efficiency (%)		90.0	93.0	93.6	93.0	92.4	91.7	
P.F. (%)	8.5	51.0	72.0	81.0	84.0	84.5	85.0	40.0

Motor Speed Data

	LR	Pull-Up	BD	Rated	Idle
Speed (RPM)	0	900	1625	1775	1800
Current (Amps)	138	115	86.0	24.1	8.5
Torque (ft-lb)	104	100	146	59.2	0.00

Information Block

HP	20.0			
Sync. RPM	1800			
Frame	256			
Enclosure	TEFC			
Construction	TFL			
Voltage	230/460#190/380 V			
Frequency	60 Hz			
Design	B			
LR Code letter	G			
Service Factor	1.15			
Temp Rise @ FL	65 °C			
Duty	CONT			
Ambient	40 °C			
Elevation	1,000 feet			
Rotor/Shaft wk ²	3.2 Lb-Ft ²			
Ref Wdg	K2564164 R26			
Sound Pressure @ 1M	65 dBA			
VFD Rating	NONE			
Outline Dwg	B-SS321151-1375			
Conn. Diag	A-EE7308			
Additional Specifications:				
0				
0				
EQUIV CKT (OHMS / PHASE)				
R1	R2	X1	X2	Xm
0.2670	0.2070	0.9900	1.4910	28.4000

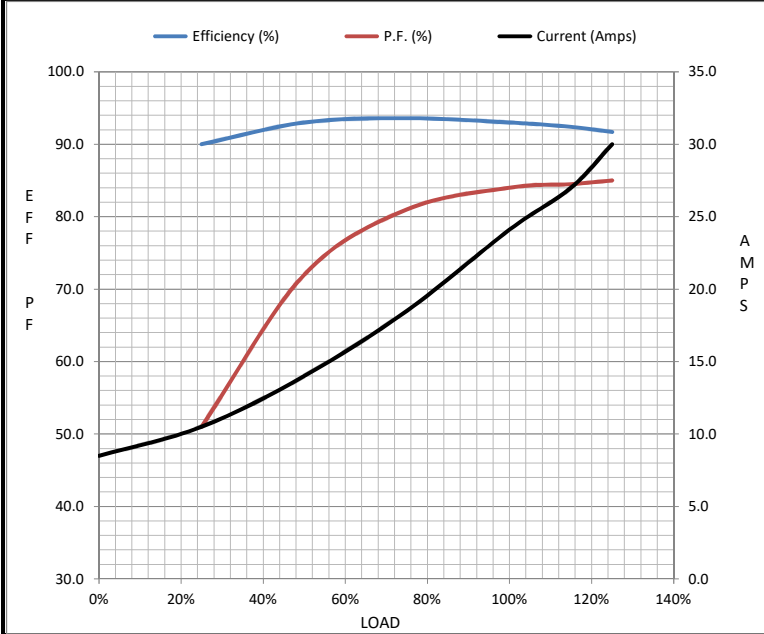

Speed - Torque Curve

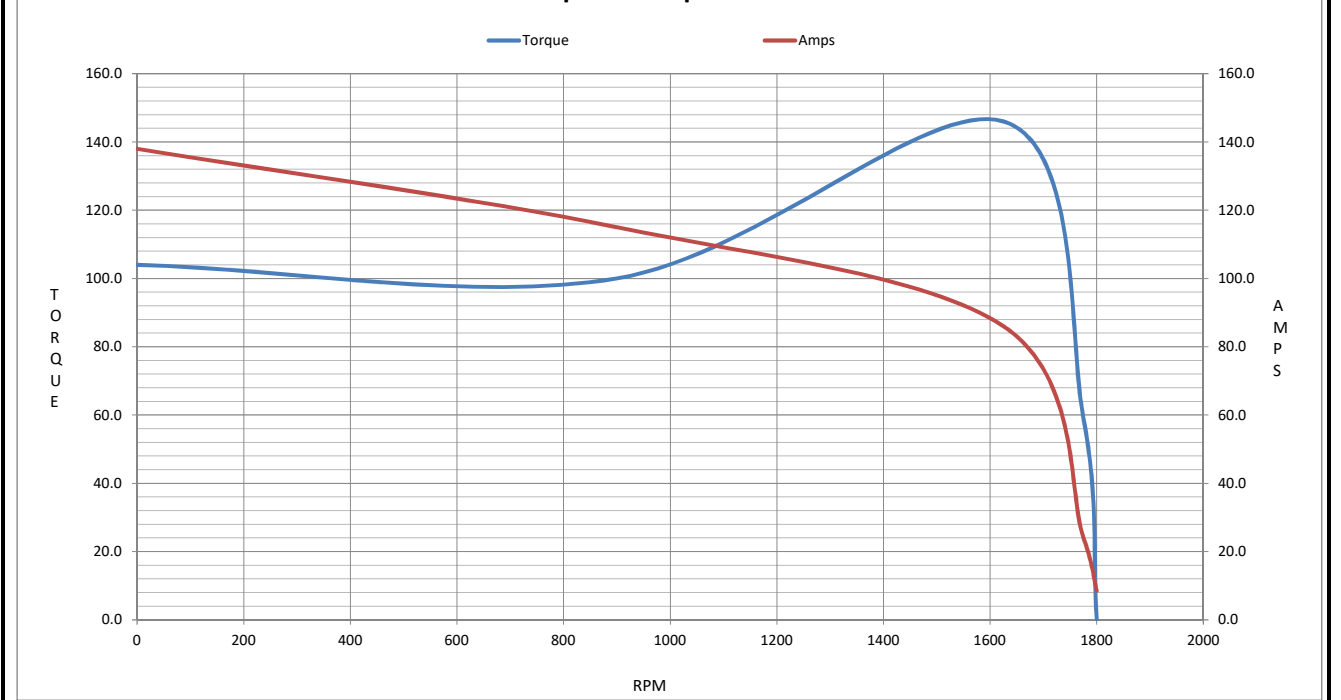

EC Declaration of Conformity

The undersigned representing
the manufacturer:

Regal Beloit America
100 East Randolph St.
Wausau, WI 54401

and the authorized representative
established within the Community:

Marathon Electric UK
6F Thistleton Road Ind. Estate
Market Overton
Oakham, Rutland LE15 7PP UK

are committed to providing customers with products that comply with applicable regulations and international protocols to which they are subject, including the requirements of the European Parliament Directive on the Harmonization of the laws relating to electrical equipment designed for use within certain voltage limits (2014/35/EU).

Regal Beloit America declares that the following product(s), to which this declaration relates, are in conformity with the relevant sections of the EC standards listed below.

This statement supersedes any statements previously issued pertaining to the product(s) listed below and is subject to change without notice.

Model No : 256TTFL16042

(Model No. may contain prefix and/or suffix characters)

Catalog No : U354A

Rework No : N/A

Directives :

Low Voltage Directive 2014/35/EU

Harmonized Standards Used :

EN 60034-1: 2010 (IEC 60034-1: 2010)

EN 60034-5: 2001/A1:2007 (IEC 60034-5: 2000/A1:2006)

Authorized Representative:



Michael A. Logsdon
Vice President, Technology

Authorized Representative in the Community:



Julian Clark
Marketing Engineer

Created on 09/01/2022

CE 22