

Vertical High Thrust Motors

INSTALLATION, OPERATION
AND MAINTENANCE MANUAL



Countless Solutions. Expert Support.



MORE THAN JUST MOTORS. WE BUILD INSIGHT.

FORECYTE™, a remote asset condition monitoring platform solution, helps intervene on imminent breakdowns and predict future ones on motors, pumps, compressors, gearboxes, fans, and more.

Partnering this IIoT condition monitoring solution with U.S. MOTORS® brand or other manufacturer's products to minimize unexpected equipment failure, reduce operating costs and extend service life.

forecyte
POWERED BY **Nidec**



Powering Products & Technologies for Everyday Life. **Nidec**

Safety First

High voltage and rotating parts can cause serious injury or loss of life. Installation, operation, and maintenance must be performed by qualified personnel. Familiarization with and adherence to NEMA MG2[†], the National Electrical Code, and local codes is recommended. It is important to observe safety precautions to protect personnel from possible injury. Personnel should be instructed to:

1. Disconnect all power to motor and accessories prior to initiating any installation, maintenance, or repairs. Also ensure that driven equipment connected to the motor shaft will not cause the motor to rotate (wind milling of fans, water flowing back through pump, etc.).
2. Avoid contact with rotating parts.
3. Act with care in accordance with this manual's prescribed procedures in handling and installing this equipment.
4. Be sure unit and accessories are electrically grounded and proper electrical installation wiring and controls are used in accordance with local and national electrical codes. Refer to "National Electrical Code Handbook" - NFPA No. 70. Employ qualified electricians.
5. Be sure equipment is properly enclosed to prevent access by children or other unauthorized personnel in order to prevent possible accidents.
6. Be sure shaft key is fully captive before unit is energized.
7. Provide proper safeguards for personnel against rotating parts and applications involving high inertia loads which can cause over speed.
8. Avoid extended exposure to equipment with high noise levels.
9. Observe good safety habits at all times and use care to avoid injury to yourself or damage to equipment.
10. Be familiar with the equipment and read all instructions thoroughly before installing or working on equipment.
11. Observe all special instructions attached to the equipment. Remove shipping fixtures if so equipped before energizing unit.
12. Check motor and driven equipment for proper rotation and phase sequence prior to coupling. Also check if a unidirectional motor is supplied and note proper rotation.
13. Electric motors can retain a lethal charge even after being shut off. Certain accessories (space heaters, etc.) are normally energized when the motor is turned off. Other accessories such as power factor correction capacitors, surge capacitors, etc. can retain an electrical charge after being shut off and disconnected.
14. Do not apply power correction capacitors to motors rated for operation with variable frequency drives. Serious damage to the drive will result if capacitors are placed between the motor and drive. Consult drive supplier for further information.

[†] All marks shown within this document are properties of their respective owners.

Table of Contents

Safety First	i
Table of Contents	ii
I. Shipment	1
II Handling	1
III. Storage	2
IV. Installation Location	6
V. Initial Installation	7
VI. Normal Operation	12
VII. Non-Reverse Ratchet	13
VIII. End Play Adjustment	13
IX. Lubrication	17
X. Troubleshooting	21
XI. Spare Parts	23
XII. Index Cutaway and Explosion Views	24
XII. Nameplate & Installation Record	65
Appendices	66
Appendix A, Motor Weights	67
Appendix B, Effects of Unbalanced Line Voltage	68
Appendix C, Variable Frequency Drives	69
Appendix D, Meter Load Test Using Watt-Hour Meter	70

I. Shipment

Prior to shipment, all motors undergo extensive mechanical and electrical testing, and are thoroughly inspected. Upon receipt of the motor, carefully inspect the unit for any signs of damage that may have occurred during shipment. Should such damage be evident, unpack the motor at once in the presence of a claims adjuster and immediately report all damage and breakage to the transportation company.

When contacting Nidec Motor Corporation (NMC) concerning the motor, be sure to include the complete motor identification number, frame, and type which appear on the nameplate.

II. Handling

The equipment needed to handle the motor includes a hoist and spreader bar arrangement (see Figure 1) of sufficient strength to lift the motor safely. The spreader bar should have the lifting rings or hooks positioned to equal the span of the lifting lugs or eyebolts. The lifting lugs or eyebolts are intended to lift the motor weight only.

WARNING

Lifting the motor by other means can result in damage to the motor or injury to personnel.

CAUTION

Do not move motor with oil sumps filled. Sloshing action of oil in sumps can result in oil leaks and motor damage.

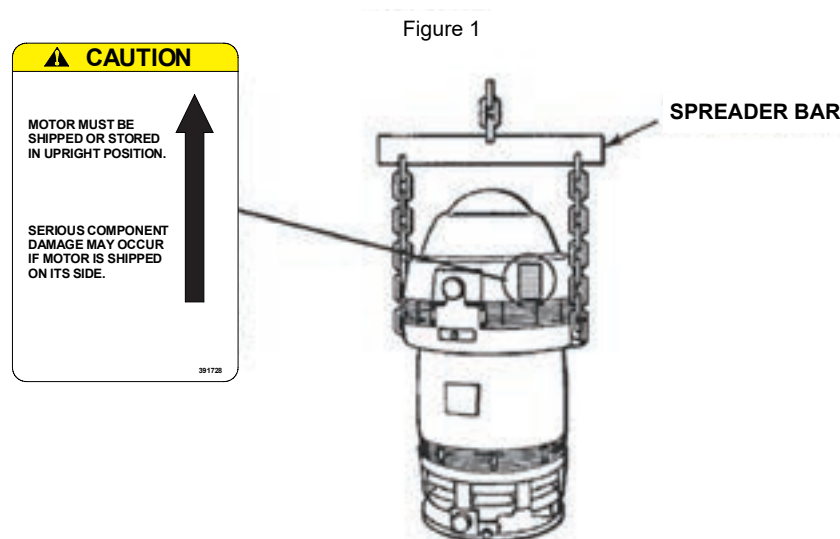

III. Storage

1) When To Put A Motor In Storage

If a motor is not put into immediate service (one month or less), or if it is taken out of service for a prolonged period, special storage precautions should be taken to prevent damage. The following schedule is recommended as a guide to determine storage needs.

- A. Out of service or in storage less than one month - no special precautions except that space heaters, if supplied, must be energized at any time the motor is not running.
- B. Out of service or in storage for more than one month but less than six months - store per items 2A, B, C, D, E, F(2), and G, items 3A, B, and C, and item 4.
- C. Out of service or in storage for six months or more - all recommendations.

2) Storage Preparation

- A. Where possible, motors should be stored indoors in a clean, dry area.
- B. When indoor storage is not possible, the motors must be covered with a tarpaulin. This cover should extend to the ground; however, it should not tightly wrap the motor. This will allow the captive air space to breathe, minimizing formation of condensation. Care must also be taken to protect the motor from flooding or from harmful chemical vapors.

NOTICE

*Immediately remove any shrink wrap used during shipping.
Never wrap any motor in plastic for storage. This can turn the motor into a moisture trap causing severe damage not covered by Nidec Motor Corporation's limited warranty.*

- C. Whether indoors or out, the area of storage should be free from excessive ambient vibration which can cause bearing damage.
- D. Precautions should be taken to prevent rodents, snakes, birds, or other small animals from nesting inside the motors. In areas where they are prevalent, precautions must be taken to prevent insects, such as dauber wasps, from gaining access to the interior of the motor.
- E. Inspect the rust preventative coating on all external machined surfaces, including shaft extensions. If necessary, re-coat the surfaces with a rust preventative material, such as Rust Veto^{®†} No. 342 (manufactured by E.F. Houghton Co.) or an equivalent. The condition of the coating should be checked periodically and surfaces re-coated as needed.
- F. Bearings:
 - 1) When storage time is 6 months or more, grease lubricated cavities must be completely filled with lubricant. Remove the drain plug and fill cavity with grease until grease begins to purge from drain opening. Refer to section IX. “**LUBRICATION**” and/or review motor’s lubrication nameplate for correct lubricant.

CAUTION

Do not re-grease bearings with drain closed or with unit running.

- 2) Oil lubricated motors are shipped without oil. When storage time exceeds one (1) month, the oil sumps must be filled to the maximum capacity as indicated on the oil chamber sight gauge window. Refer to motor lubrication nameplate or Section IX “Lubrication” for proper oil.

NOTE: Motor must not be moved with oil in reservoir. Drain oil before moving to prevent sloshing and possible damage. With a clean cloth, wipe any excess oil from the threads of the drain plug and the inside of the drain hole. Apply Gasoila^{®†} P/N SS08 or equivalent thread sealant to the threads of the drain plug and replace the plug in the oil drain hole. Refill oil when motor has been moved to the new location.

- G. To prevent moisture accumulation, some form of heating must be utilized. This heating should maintain the winding temperature at a minimum of 5° above ambient. If space heaters are supplied, they should be energized. If none are available, single phase or “trickle” heating may be utilized by energizing one phase of the motor’s winding with a low voltage. Request the required voltage and transformer capacity from Nidec Motor Corporation. A third option is to use an auxiliary heat source and keep the winding warm by either convection or blowing filtered warm air into the motor.

3) Periodic Maintenance

- A. Oil should be inspected monthly for evidence of moisture or oxidation. The oil must be replaced whenever contamination is noted or every twelve months, whichever occurs first. It is important to wipe excess oil from the threads of the drain plug and the drain hole and to coat the plug threads with Gasoila^{®†} P/N SS08 or equivalent thread sealant before replacing the drain plug.
- B. Grease lubricated bearings must be inspected once a month for moisture and oxidation by purging a small quantity of grease through the drain. If any contamination is present, the grease must be completely removed and replaced.
- C. All motors must have the shaft rotated once a month to maintain a lubricant film on the bearing races and journals.

D. Insulation Testing:

Two tests are used to evaluate the condition of the winding insulation. The first of these is the one minute insulation resistance test (IR_1) and the second is the polarization index test (PI), which can also be referred to as a dielectric absorption test. The results of either of these tests can be skewed by factors such as the winding temperature and its relation to the dew point temperature at the time the test was conducted. The PI test is less sensitive to these factors than the IR_1 test, but its results can still be affected significantly. Due to these factors, the most reliable method for evaluating the condition of the winding insulation is to maintain a record of periodic measurements, accumulated over months or years of service, for one or both of these tests. It is important that these tests be conducted under similar conditions of the winding insulation is to maintain a record of periodic measurements, accumulated over months or years of service, for one or both of these tests. It is important that these tests be conducted under similar conditions of winding temperature, dew point temperature, voltage magnitude and duration, and relative humidity. If a downward trend develops in the historical data for either test, or if the readings from both tests drop below a minimum acceptable value, have an authorized electrical apparatus service shop thoroughly clean and dry the winding, and retreat, if necessary.

1. The recommended procedure for the IR_1 test is as follows:

- (1) Disconnect all external accessories or equipment that have leads connected to the winding and connect them to a common ground. Connect all other accessories that are in contact with the winding to a common ground.

⚠ WARNING

Failure to have accessories grounded during this test can lead to the accumulation of a hazardous charge on the accessories.

- (2) Using a megohmmeter, apply DC voltage at the level noted below for 1 minute and take a reading of the insulation resistance between the motor leads and ground.

<u>Rated Motor Voltage</u>	<u>Recommended DC Test Voltage</u>
UP to 1000 (inclusive)	500 VDC
1001 to 2500 (inclusive)	500 to 1000 VDC
2501 to 5000 (inclusive)	500 to 2500 VDC
5001 and up	500 to 5000 VDC

⚠ WARNING

Follow appropriate safety procedures during and after high voltage testing. Refer to the instruction manual for the test equipment. Make sure the winding insulation is discharged before beginning the test. The winding insulation will retain a potentially dangerous charge after the DC voltage source is removed, so use proper procedures to discharge the winding insulation at the end of the test. Refer to IEEE 43™ Standard for additional safety information.

- (3) The reading should be corrected to a 40°C base temperature by utilizing the formula:

$$R_{40C} = K_T R_T$$

Where:

R_{40C} = insulation resistance (in megohms) corrected to 40°C

K_T = insulation resistance temperature coefficient at temperature T°C

R_T = measured insulation resistance (in megohms) at temperature T°C

The value of K_T can be approximated by using the formula:

$$K_T = (0.5)^{(40-T) / 10}$$

Where:

T = the winding temperature in °C that the insulation resistance was measured at

The recommended procedure for the PI test is as follows:

- (1) Perform steps 1 and 2 from the IR_1 test procedure. Heed the safety warnings given in the IR_1 test procedure.
- (2) With DC voltage still being applied by the megohmmeter, taken an additional reading of insulation resistance between the motor leads and ground 10 minutes after the DC voltage was initially applied. To minimize measurement errors, the variation in winding temperature between the 1 minute and 10 minute readings should be kept to a minimum.
- (3) Obtain the polarization index by taking the ratio of the 10 minute resistance reading to the 1 minute resistance reading.

If historical data from previous IR_1 and / or PI tests is available, then a comparison of the present test result to previous tests can be used to evaluate the condition of the insulation. To minimize error, all readings that are compared should be taken at test voltages, winding temperatures, and relative humidities that are similar as possible. If a downward trend in the readings develops over time, have an authorized electrical apparatus service shop thoroughly clean and dry the winding and, if necessary, retreat the winding. Then, repeat the test and re-check results before returning the motor service.

If historical data from previous IR_1 or PI tests is not available, then compare readings from the present test to the recommended minimum values listed below. If the readings from both tests fall below the minimum, have an authorized electrical apparatus service shop thoroughly clean and dry the winding and, if necessary, retreat the winding. Then, repeat the tests and re-check results before turning the motor to service.

The recommended minimum value for the 1 minute insulation resistance reading corrected to 40°C is:

Rated Motor Voltage

Up to 999 (inclusive)
1000 and up

Minimum Insulation Resistance

5 Megohms
100 Megohms

The recommended minimum value for the polarization index is 2.0 if the 1 minute insulation resistance reading corrected to 40°C is above 5000 megohms, however, the polarization index may not be meaningful. In such cases, the polarization index may be disregarded as a measure of insulation condition.

Refer any question to the Nidec Motor Corporation Product Service Department.

For more information, refer to the IEEE 43™ Standard.

4. Start-up Preparations After Storage

- A. Motor should be thoroughly inspected and cleaned to restore to an “As Shipped” condition.
- B. Motor which has been subjected to vibration must be disassembled and each bearing inspected for damage.
- C. When storage time has been six (6) months or more, oil and/or grease must be completely changed using lubricants and methods recommended on the motor's lubrication plate, or in **Section IX - “LUBRICATION”**
- D. The winding must be tested to obtain insulation resistance and dielectric absorption ratio as described in **Section III., item 3.**
- E. Contact Nidec Motor Corporation Product Service Department prior to start-up if storage time has exceeded one year.

IV. Installation Location

When selecting a location for the motor and driven unit, keep the following items in mind:

- 1) The location should be clean, dry, well-ventilated, properly drained, and provide accessibility for inspection, lubrication, and maintenance. Ambient vibration should be kept to a minimum. Outdoor installations on open dripproof motors require protection from the elements.
- 2) The location should provide adequate space for motor removal without shifting the driven unit.
- 3) Temperature rise of a standard motor is based upon operation at an altitude not exceeding 3300 feet (1000 meters) above sea level, and a maximum ambient temperature of 40°C unless specified otherwise on nameplate. See NEMA^{®†} MG-1 20.28 for usual service conditions.
- 4) To avoid condensation inside the motor, it should not be stored or operated in areas subject to rapid temperature changes unless it is energized or protected by space heaters.
- 5) The motor should not be installed in close proximity to any combustible material or where flammable gases maybe present, unless it is specifically built for that environment and is U.L. labeled accordingly.
- 6) Oil lubricated motors must be mounted within one degree of true vertical. Failure to do so will result in oil leakage and possibly bearing failure.

7) Recommended Minimum Installation Clearances

This is a general guide and cannot cover all circumstances. Unusual arrangements should have inquiries to Nidec Motor Corporation Product Service Department. Unusual arrangements might include high ambient, limited ventilation, or a large number of motors in a coned space. The distance to the wall is at the side or end of the motor. The distance to another motor is considered as surface to surface and for side-by-side arrangements. This recommendation considers all motors to be mounted in the same orientation (e.g. all main conduit boxes facing east).

Speed	Distance to Wall	Distance to Another Motor
3600 RPM	2 x motor width	2 x motor width
1800 RPM or Less	1 x motor width	

V. Initial Installation

CAUTION

Any rotating component removed to facilitate installation of motor should be witness marked to assist in reassembly as not to affect the overall motor balance. All loosened or removed parts must be reassembled and tightened to original specifications.

1. General

Reliable, trouble free operation of a motor and driven unit depends on a properly designed foundation and base plus good alignment. If the motor and driven unit are not installed properly, the following may result:

- * Noisy Operation
- * Excessive vibration
- * Bearing damage or failure
- * Motor failure

2. Shaft Alignment

On HOLLOSHAFT® motors, the pump shaft and motor coupling must be aligned within .003" TIR. On solid shaft motors, the motor and pump shafts must be aligned within .002" TIR.

3. Pump Shaft Adjustment (HOLLOSHAFT® motors only)

To facilitate axial pump shaft adjustment, a locking feature is provided to lock the motor shaft against rotation. The two types of locking features are as follows:

- A. Locking arm (Figure 2) - The locking arm is bolted to a stationary part and is pinned (for best results use arm in tension) or interferes with a rotating part (when locking arm is not in use it should be moved out of the way and bolted in place). A non-reverse ratchet functions as a locking device. Motors supplied with a non-reverse ratchet are not equipped with a locking arm.
- B. Pinning through mating holes - Holes are provided in both a stationary and rotating part which line up allowing insertion of a pin.

Figure 2

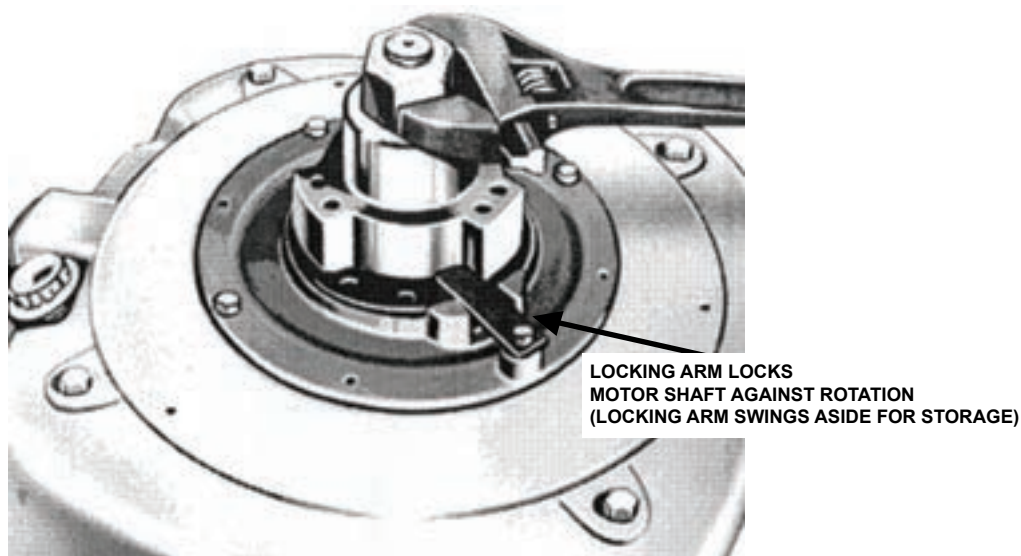

⚠ WARNING

Locking device must be disengaged prior to starting motor or motor damage and/or injury to personnel can result.

⚠ CAUTION

Care should be exercised when lowering the motor over the pump shaft so that the oil retaining tube in the lower bracket is not damaged (applies only to motors with oil lubricated lower bearing).

4. Drive Coupling (HOLLOSHAFT® units only).

The drive coupling may be utilized in one of two ways:

- A. Bolted type (Figure 3) - Hold down bolts are installed (some motors require removal of driving pins to allow installation of hold down bolts) in the drive coupling to prevent upward movement of the pump shaft. This will allow momentary upthrust from the pump to be taken by the motor's guide bearing.

⚠ WARNING

Failure to tighten coupling and non-reverse ratchet bolts to required torque values can cause bolts to break, resulting in equipment damage or injury to personnel.

⚠ WARNING

Failure to tighten coupling and non-reverse ratchet bolts to the required torque values shall cause bolts to break, resulting in equipment damage or injury to personnel.

Figure 3
Bolted Coupling

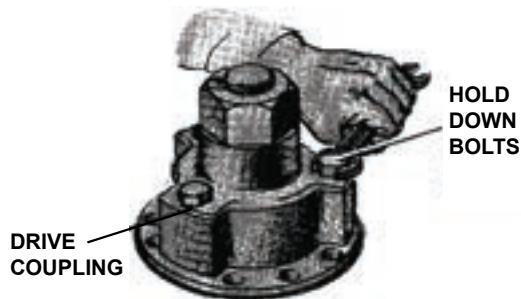
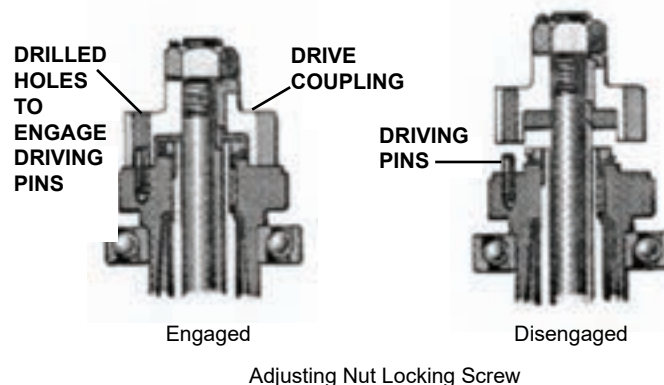

Figure 4
Self Release Coupling



B. Self-release type (Figure 4) - Driving pins are used to engage the drive coupling with the rotor. A power reversal may unscrew the joints of the pump shafting, causing the shafting to lengthen and buckle or break if the shafting is restrained. The self-release coupling will lift out of engagement with partial unscrewing of the shafting, thus stopping further rotation of the pump. The following items must be followed for proper functioning of the self-release coupling:

- The pump shaft adjusting nut must be properly secured to the drive coupling with a locking screw
- The drive coupling should not bind on the driving pins
- The drive coupling must not be bolted down
- The pump shaft must be concentric to the motor shaft to prevent rubbing of the pump shaft inside the motor shaft
- There must be no potential for upthrust in the application
- Do not use the self-release feature in conjunction with a lower steady bushing, as friction between the parts can damage the line shafting and/or bushing
- Due to the possibility of sparking as the parts separate, the self-release feature must not be used in an environment where explosive gases or dust may be present

⚠ WARNING

Should a motor supplied with a self-release coupling become uncoupled, the motor and pump must be stationary and all power locked out before manually re-coupling.

5. Water Cooling For Bearing Oil Reservoir.

If the motor is equipped with cooling coils in the oil reservoir, a minimum water supply of 4 GPM must be maintained at a maximum of 125 PSI with a 32°C (90°F) maximum inlet temperature. External water connections must be self draining to prevent cooling coil rupture at freezing temperatures. Use clean, noncorrosive water only. If corrosive conditions exist and are specified at time of motor order, special corrosion resistant fittings can be supplied.

6. Electrical Connection

Refer to the motor nameplate for power supply requirements and to the connection diagram on the motor. Be sure connections are tight. Check carefully and assure that they agree with the connection diagram, then insulate all connections to be sure that they will not short against each other or to ground. Be sure the motor is grounded to guard against possible electrical shock. Refer to the National Electrical Code Handbook (NFPA No. 70) and to local electrical codes for proper wiring, protection, and wire sizing. Be sure proper starting equipment and protective devices are used for every motor. For assistance, contact the motor starter manufacturer.

Part Winding Starters: Part winding starters used with part winding start motors should have the timer set at a minimum time consistent with the power company requirements. The recommended maximum time on part winding is two seconds. Setting the timer for longer periods can cause permanent damage to the motor and may void the warranty. Note that motor may or may not start on part winding start connection.

7. Direction Of Rotation

As a standard, motors that are equipped with a non-reverse ratchet are designed to operate in a counterclockwise direction as viewed from the top of the motor. Also, some high speed motors have unidirectional ventilating fans. When the motor has a unidirectional ventilating fan, the direction of rotation is indicated by an arrow mounted on the motor and by a warning plate mounted near the main nameplate.

CAUTION

*Apply power **momentarily** to observe the direction of rotation for which the leads are connected. Motor damage may occur if power is applied for more than ten seconds while rotation is locked against the non-reverse ratchet. The motor should be uncoupled from the driven equipment during this procedure to assure driven equipment is not damaged by reverse rotation. Couplings (if installed) should be properly secured.*

For a 3 phase motor, to reverse the direction of rotation (if the motor is not operating in the correct direction), interchange any two of the three power leads on the motor. For a 1 phase motor, if the motor is not operating in the correct direction, follow the instructions on the connection plate attached to the motor in order to reverse the direction of rotation. For both 1 and 3 phase motors, be sure that the power is off and steps are taken to prevent accidental starting of the motor before attempting to change electrical connection.

8. Spring-Preloaded Thrust Bearings

Motors built with spherical roller thrust bearings (bearing number 29xxx) at any speed or tandem angular contact thrust bearings (bearing number 7xxx) on large 3600 or 3000 RPM (2-pole) motors have preload springs which maintain a minimum thrust load at all times to prevent bearing skidding. These motors require a minimum external thrust load sufficient to compress the springs to properly seat the thrust bearing and to relieve the lower guide bearing of axial spring thrust. Refer to motor's minimum thrust nameplate for required thrust.

CAUTION

Do not run a motor which has bearing preload springs without thrust load for more than fifteen (15) minutes as bearing damage can result.

9. Initial Start

After installation is completed, but before motor is put into regular service, make an initial start as follows:

- A. Ensure that motor and control device connections agree with wiring diagrams.
- B. Ensure that voltage, phase, and frequency of line circuit (power supply) agree with motor nameplate.
- C. Check insulation resistance according to Section III "STORAGE" item 3.
- D. Check all foundation, base, non-reverse ratchet (if applicable), and coupling bolts (if applicable) to ensure they are tight.
- E. If motor has been in storage, either before or after installation, refer to Section III "STORAGE" Item 4 for preparations.
- F. Motors are tested with oil at our manufacturing facility then drained prior to shipment.

Note: A small amount of residual oil and rust inhibitor will remain in the oil sump. This residual oil and rust inhibitor is compatible with Turbine Type Mineral Oils and Synthetic, PAO (Poly Alpha Olefin) based oils listed in this manual. It is not necessary to drain this residual oil when adding new oil for operation. Check oil lubricated units to be certain that bearing housings have been filled to between the "MAX" and "MIN" levels on the sight gauge windows with the correct lubricant. Refer to Section IX "LUBRICATION" for proper oils.

- G. Check for proper or desired rotation. See item 7 of this section for details.
- H. Ensure that all protective devices are connected and operating properly, and that all outlet accessory, and access covers have been returned to their original intended position.
- I. Start motor at lowest possible load and monitor to be sure that no unusual condition develops.

WARNING

All loosened or removed parts must be reassembled and tightened to original specifications. Keep all tools, chains, equipment, etc. clear of unit before energizing motor.

- J. When checks are satisfactory to this point, increase load slowly up to rated load and monitor unit for satisfactory operation.

VI. Normal Operation

Start the motor in accordance with standard instructions for the starting equipment used.

1. General Maintenance

Regular, routine maintenance is the best assurance of trouble-free, long-life motor operation. It prevents costly shutdown and repairs. Major elements of a controlled maintenance program are:

- A. Trained personnel who have a working knowledge of rotational equipment and have read this manual.
- B. Systematic records which contain at least the following:
 1. Complete nameplate data
 2. Prints (wiring diagrams, certified outline dimensions)
 3. Alignment data
 4. Results of regular inspection, including vibration and bearing temperature data, as applicable
 5. Documentation of any repairs
 6. Lubrication data:
 - Method of application
 - Types of lubricants for wet, dry, hot, or adverse locations
 - Maintenance cycle by location (some require more frequent lubrication)

2. Inspection and Cleaning

Stop the motor before cleaning. **CAUTION: Assure against accidental starting of the motor.** Clean the motor inside and out regularly. The frequency of cleaning depends upon actual conditions existing around the motor. Use the following procedures as they apply:

- A. Wipe off dirt, dust, oil, water, or other liquids from external surfaces of motor. These materials can work into or be carried into the motor windings and may cause overheating or insulation breakdown.
- B. Remove dirt, dust, or debris from ventilating air inlets. Never allow dirt to accumulate near air inlets. Never operate motor with air passages blocked.
- C. Clean motors internally by blowing with clean, dry, compressed air at 40 to 60 PSI. If conditions warrant, use a vacuum cleaner.

CAUTION

When using compressed air, always use proper eye protection to prevent accidental eye injury.

- D. When dirt and dust are solidly packed, or windings are coated with oil or greasy grime, disassemble the motor and clean with solvent. Use only high-flash naphtha, mineral spirits, or Stoddard solvent. Wipe with solvent dampened cloth, or use suitable soft bristled brush. DO NOT SOAK. Oven dry (150 - 175°F) solvent cleaned windings thoroughly before reassembly.
- E. After cleaning and drying the windings, check the Insulation resistance per Section III, Item 3.

VII. Non-Reverse Ratchet

Units featuring non-reverse ratchets are refine-balanced by attaching weights to the rotating ratchet. If the ratchet is removed, it should be marked and reassembled in the same position to retain proper balance.

VIII. Endplay Adjustment

The term endplay is defined as the total axial float of the rotor. Should the motor be disassembled for any reason, the rotor endplay must be adjusted. Care must be taken to ensure that end play is within the proper range. Use one of the following procedures, depending upon the type of thrust bearing to set and play:

CAUTION

Excessive endplay can allow the thrust bearing to separate when units are run with zero thrust or momentary up thrust, resulting in thrust bearing failure. Insufficient endplay may cause the bearings to load against each other, resulting in extreme heat and rapid failure of both the guide and thrust bearings.

End play is defined as the amount of free axial travel that the rotor has when thrust in both directions. To prevent both preloading of the guide bearing and excessive end float, end play should be adjusted to be within an acceptable range. Required end play depends upon the location of the thrust bearing (whether it is in the lower or upper end of the motor).

Angular Contact Thrust Bearing(s) (7XXX) in Lower End of Motor

APPLICABLE FRAMES	APPLICABLE TYPES	END PLAY SETTING
182 THRU 286	TU, TV4, LU, LV4, EU, EV4, NU, NV4, AU, AV4	.015 - .020
324 THRU 365	TU, TV4, LU, LV4, EU, EV4, NU, NV4	.020 - .025

Adjust end play by adding shims above the upper guide bearing. End play should be rechecked after addition of shims to verify setting. Turn rotor by hand to ensure that components are not rubbing and unit turns freely.

Note: Motors with opposed thrust bearings (e.g. 7XXX Back-to-Back mounted) or with a single double-row angular contact bearing (i.e. 5XXX) or a single Conrad deep-groove bearing (6XXX) in the lower end of the motor do not require shimming. End play on these motors is controlled entirely by the internal clearance in the lower bearing(s).

Angular Contact Brg(s) (7XXX) or Spherical Roller Thrust Brg (29XXX) in Upper End of Motor

APPLICABLE FRAMES	APPLICABLE TYPES	END PLAY SETTING
324 THRU 365	RU, RV4	.005 to .008
404 & UP	RU, RV4, HU, HV4, TU, TV4, LU, LV4, EU, EV4, NU, NV4, JU, JV4	
449	JV, JV3	
6808 & UP	HV, RV	

Adjust end play by turning the locknut above the bearing mounting until the lower bearing contacts the bearing cap fingers and then back of the locknut until the required end play is achieved and secure with lockwasher tab. Turn rotor assembly by hand to ensure that components are not rubbing and unit turns freely. Prick punch the end of the shaft and locknut for permanent identification of end play setting at the factory.

Notes;

1. Use of hydraulic jacking means or hoists can be useful in adjusting end play on units with spring preloaded bearings or large rotors. Use caution as excessive hydraulic force can cause deflection of parts which can then lead to a false end play reading and highly preloaded bearings.

1. Spherical Roller Thrust Bearings and Angular Contact Bearings (With Springs).

Setting the correct end play on units with spring-preloaded spherical roller or angular contact thrust bearings requires a controlled assembly method, due to various deflections internal to the motor and friction of locknut threads from spring force. An end play setting of .005 to .008 inches is required to allow the lower guide bearing to return to an unloaded position when external thrust is applied to the motor (see Figure 5). End play can be properly adjusted by the following recommended procedure:

- A. Place spring retainer (without springs) and lower thrust washer of bearing into upper bearing bore.
- B. Using a depth micrometer, measure the distance between the top and lower thrust washer and the faced surface on top of the bearing housing (see Figure 5). Record dimension to three decimals.
- C. Add .005 to .008 inches to the recorded dimension to obtain the correct endplay range for the unit.
- D. Reassemble bearing with springs. Motor is now ready to set and play. Several acceptable methods for setting endplay are following.

NOTE: Certain motor builds require removal of the fabricated steel or cast aluminum oil baffle to provide access for depth micrometer measurements.

Figure 5

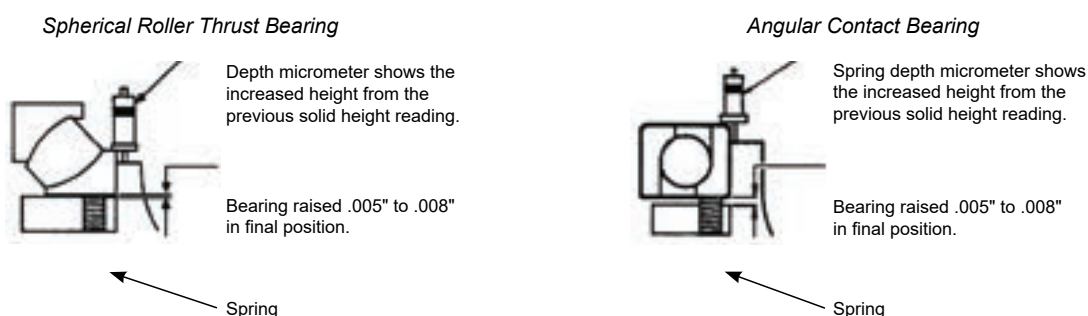

2. Angular Contact Ball Bearings (Without Springs)

- A. No preliminary measurements are required to set and play. End play may be set by any of the following methods described in this section.
- B. To correctly adjust the endplay setting, a dial indicator should be positioned to read the shaft axial movement. (See figure 7 for location and dial indicator). The rotor adjusting locknut should be turned until no further upward movement of the shaft is indicated. The locknut is then loosened until .005 to .008" endplay is obtained. Lock the locknut with lock washer.

CAUTION

Care should be taken to ensure that the locknut is not over-tightened, as this can lead to an erroneous end play setting (due to deflection of parts) and bearing damage may result.

C. Motors that have two opposed angular contact bearings that are locked for up an downthrust do not require endplay adjustment. The shaft, however, should be set to the original 'AH' (shaft extension length) to prevent the guide bearing from taking thrust.

END PLAY ADJUSTMENT METHODS

1. Method 1 (refer to Figures 6 & 7)

This method requires the user to install a bolted chain from the bearing mount back to a lifting lug. Rotate the locknut with a spanner wrench (and bar extension) until dial indicator shows no movement on end of shaft. The locknut should then be loosened until proper endplay is obtained, lock the locknut with lock washer. (See Figure 7 for location of dial indicator.)

NOTE: This is the lowest cost of the three methods and requires the least amount of equipment. This method, however, may be less desirable than Method 2 as considerable locknut torque may be encountered on units with bearing preload springs.

Special equipment required:

- Locking bolts
- 3/4" chain
- Spanner wrench with extension
- Dial indicator
- Depth micrometer

Figure 6 (Method 1)

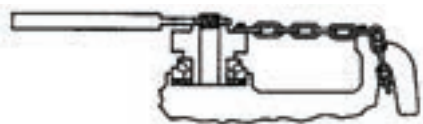

Mounting springs are compressed and rotor is lifted by locknut

Figure 7 (Method 1 & 3)

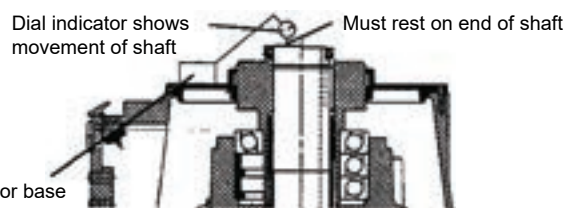

Dial indicator base must rest on a stationary part as close as possible to shaft.

2. Method 2 (refer to Figure 8 - Utilized on spring Loaded Bearings Only)

This method utilizes a spreader bar and chains to wrap around lifting lugs, a hydraulic jack (five ton), and crane to lift the spreader bar. The hydraulic jack is supported by two steel blocks of equal thickness on top of the bearing mounting with the jack pushing against the spreader bar. On large motors, the rotor can be lifted by placing a second jack below the motor shaft to allow the locknut to be turned easily.

NOTE: This method utilizes typical shop equipment and tools. Endplay settings can be checked quickly on larger vertical motor products. The locknut lifts rotor weight only.

Equipment required:

- Large spreader bar with chains and locking bolts
- Overhead crane
- Spanner wrench
- 5-ton hydraulic jack
- Depth micrometer
- Metal blocks
- Dial indicator

Figure 8 (Method 2)

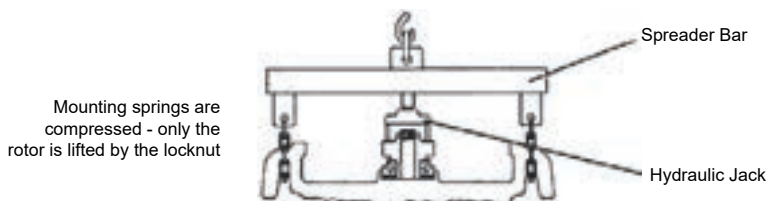

3. Method 3 (refer to Figure 9)

This method uses a one inch thick steel disc with a center hole for the shaft end bolt and two threaded hydraulic jacks connected to a single pump. Apply load to hydraulic jacks until dial indicator shows no movement on end of shaft. (See Figure 7 for location of dial indicator). The shaft locknut should be positioned and the pressure from hydraulic jack relieved until proper endplay is obtained.

⚠ CAUTION

Use of excessive hydraulic pressure can damage bearings.

NOTE: This method is directly usable on solid shaft motors and can be used on most HOLLOSHAFT® motors with the use of a long threaded rod and plate. It is easy to apply and settings can be checked quickly, especially in field service. The locknut does not see any force and can be turned easily.

Equipment required:

- Fixture with hydraulic jacks
- Dial indicator
- Spanner wrench

Figure 9 (Method 3)

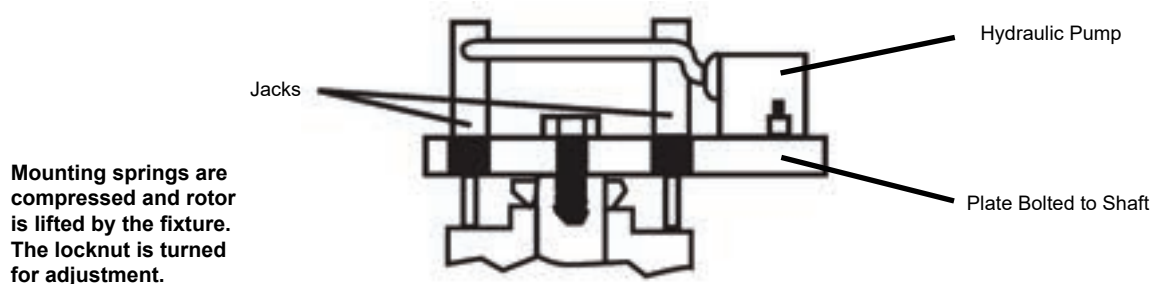

⚠ CAUTION

After setting endplay, run unit for three to five minutes, then stop and verify the endplay setting. Readjust as necessary. All loosened or removed parts must be reassembled and tightened to original specifications. Keep all tools, chains, equipment, etc. clear of unit before energizing motor.

IX. Lubrication

Motor must be at rest and electrical controls should be locked open to prevent energizing while being serviced. If motor is being taken out of storage, refer to **Section III “STORAGE”, item 4** for instructions.

1. Oil lubricated bearings

Motors are tested with oil at our manufacturing facility then drained prior to shipment. A small amount of residual oil and rust inhibitor will remain on the oil sump. This residual oil and rust inhibitor is compatible with Turbine Type Mineral Oils and Synthetic, PAO (Poly Alpha Olefin) based oils listed in this manual. It is not necessary to drain this residual oil when adding new oil for operation.

Change oil once per year with normal service conditions. Frequent starting and stopping, damp or dusty environment, extreme temperature, or any other severe service conditions will warrant more frequent oil changes. If there is any question, consult Nidec Motor Corporation Product Service Department for recommended oil change intervals regarding your particular situation.

Determine required oil ISO Viscosity Grade (VG) and base oil type from Table 3, then see Table 4 and 5 for approved oils. Add oil into oil fill hole at each bearing housing until the oil level reaches between minimum and maximum marks located on the sight of the gauge window. Figure 10 illustrates a typical oil level window or column to confirm oil fill. Oil level should be confirmed with motor off and should be not be above the max fill line or below the min fill line. It is important to wipe excess oil from the threads of the drain hole and to coat the plug threads with Gasoil[®] P/N SS08, manufactured by Federal Process Corporation or equivalent thread sealant before replacing the drain plug. Plug should be tightened to a minimum of 20 lb.-ft. using a torque wrench. See the motor nameplate or Table 7 for the approximate quantity of oil required.

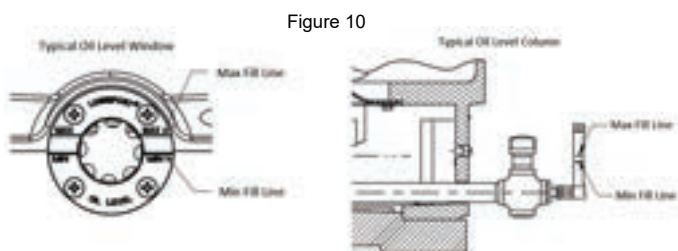

2. Grease Lubricated Bearings

A. Relubrication of Units In Service

Grease lubricated bearings are pre-lubricated at the factory and normally do not require initial lubrication. Relubricating interval depends upon speed, type of bearing and service. Refer to Table 1 or suggested regreasing intervals and quantities. Note that operating environment and application may dictate more frequent lubrication. To relubricate bearings, remove the drain plug. Inspect grease drain and remove any blockage (caked grease or foreign particles) with a mechanical probe, taking care not to damage bearing.

⚠ WARNING

Should a motor supplied with a self-release coupling become uncoupled, the motor and pump must be stationary and all power locked out before manually re-coupling.

Add new grease at the grease inlet. New grease must be compatible with the grease already in the motor (refer to table 2 and 6 for recommended greases).

⚠ WARNING

Greases of different bases (lithium, polyurea, clay, etc.) may not be compatible when mixed.

Mixing such greases can result in reduced lubricant life and premature bearing failure.

Prevent such intermixing by disassembling motor, removing all old grease and repacking with new grease per item B of this section. Refer to Table 2 for recommended greases.

Run the motor for 15 to 30 minutes with the drain plug removed to allow purging of any excess grease. Shut off unit and replace the drain plug. Return motor to service.

⚠ WARNING

Overgreasing can cause excessive bearing temperatures, premature lubricant breakdown and bearing failure. Care should be exercised against overgreasing.

B. Change of Lubricant

Motor must be disassembled as necessary to gain full access to bearing housing(s).

Remove all old grease from bearings and housings (including all grease fill and drain holes). Inspect and replace damaged bearings. Fill bearing housings both inboard and outboard of bearing approximately 30 percent full of new grease. Grease fill ports must be completely charged with new grease. Inject new grease into bearing between rolling elements to fill bearing. Remove excess grease extending beyond the edges of the bearing races and retainers.

Table 1

Recommended Grease Replenishment Quantities & Lubrication Intervals

Bearing Number		Grease Replenishment Quantity (Fl. Oz.)	Lubrication Interval		
62xx, 72xx	63xx, 73xx		1801 thru 3600 RPM	1201 thru 1800 RPM	1200 RPM and slower
03 thru 07	03 thru 06	0.2	1 Year	2 Years	2 Years
08 thru 12	07 thru 09	0.4	6 Months	1 Year	1 Year
13 thru 15	10 thru 11	0.6	6 Months	1 Year	1 Year
16 thru 20	12 thru 15	1.0	3 Months	6 Months	6 Months
21 thru 28	16 thru 20	1.8	3 Months	6 Months	6 Months

Refer to motor nameplate for bearings provided on a specific motor. For bearings not listed in Table 1, the amount of grease required may be calculated by the formula:

$$G = 0.11 \times D \times B$$

Where: G = Quantity of grease in fluid ounces
D = Outside diameter of bearing in inches
B = Width of bearing in inches

Table 2

Recommended Greases

Motor Frame Size	Motor Enclosure	Grease Manufacturer	Grease (NLGI Grade 2)
All Thru 447	All	Exxon Mobil	Polyrex-EM
449 and Up	Open Dripproof		
449 and Up	TEFC and Explosionproof		Mobilith SHC-100

The above greases are interchangeable with the grease provided in units supplied from the factory (unless stated otherwise on motor lubrication nameplate).

Table 3
Nidec Motor Corporation Recommended Oil Viscosities

Use chart below when "no" special lubrication plate is attached to the motor

Angular Contact Thrust Bearing (7XXX Series) (ABMA BT-Series)						
Motor Enclosure	Frame Size	Speed (RPM)	Ambient Temperature	ISO VG	Base Oil Type	
Open Dripproof or Weather Protected	324 and larger	All	-15°C thru 40°C (5-104°F)	32	Mineral or Synthetic	
			41°C thru 50°C (105-122°F)	68	Synthetic Only	
-15°C thru 40°C (5-104°F)	404 thru 447		32	Mineral or Synthetic		
			41°C thru 50°C (105-122°F)	68	Synthetic Only	
Totally Enclosed or Explosion proof	449 thru 5811		1801-3600	-15°C thru 40°C (104°F)	32	Synthetic Only
			1800 & below		68	Synthetic Only
		All	41°C thru 50°C (105-122°F)	Refer to Office		

Spherical Roller Thrust Bearing (29XXX Series) (ABMA TS-Series)					
Motor Enclosure	Frame Size	Speed (RPM)	Ambient Temperature	ISO VG	Base Oil Type
Open Dripproof or Weather Protected	444 and larger	1800 and below	-15°C thru 25°C (5-77°F)	68	Mineral or Synthetic
			6°C thru 40°C (42-104°F)	150	
			41°C thru 50°C (105-122°F)		
Totally Enclosed or Explosion proof	449 and larger		-15°C thru 25°C (5-77°F)	68	Mineral or Synthetic
			6°C thru 40°C (42-104°F)	150	Synthetic Only
			41°C thru 50°C (105-122°F)	Refer to Office	

Notes:

1. If lower guide bearing is oil lubricated, it should use the same oil as the thrust bearing.
2. If lower guide bearing is grease-lubricated, refer to TABLE 2 for recommended greases.
3. Refer to Nidec Motor Corporation for ambient temperatures other than those listed.

Table 4
Nidec Motor Corporation Approved Oil Specifications For Use with Anti-Friction Bearings

Oil Manufacturer	ISO VG 32		SO VG 68		ISO VG 150	
	Viscosity: 130-165 SSU @ 100F		Viscosity: 284-347 SSU @100F		Viscosity: 620-765 SSU @ 100F	
	Mineral Base Oil	Synthetic Base Oil	Mineral Base Oil	Synthetic Base Oil	Mineral Base Oil	Synthetic Base Oil
Chevron Texaco	Regal R&O 32	Cetus HiPerSyn 32 Cetus PAO 32	Regal R&O 68	Cetus HiPerSyn 68 Cetus PAO 68	Regal R&O 150	Cetus HiPerSyn 150 Cetus PAO 150
ExxonMobil	DTE Oil Light Teresstic 32	SHC 624	DTE Oil Heavy Medium Teresstic 68	SHC 626	DTE Oil Extra Heavy Teresstic 150	SHC 629
Conoco Phillips 66	Multipurpose R&O 32	Syncon R&O 32	Multipurpose R&O 68	Syncon R&O 68	Multipurpose R&O 150	Syncon R&O 150
Shell Oil Co.	Turbo T 32 Tellus S2 MX 32	Tellus S4 ME 32	Turbo T 68 Tellus S2 MX 68 Morlina S2B 68	Tellus S4 ME 68	Morlina S2B 150	X

Table 5 Recommended Food Grade Oils (NSF HI)

Company	ISO VG32	ISOVG46	ISOVG68	ISOVG100	ISO VG150
	130-165 SSU @ 100F	190-235 SSU @ 100F	284-347 SSU @ 100F	415-510 SSU @ 100F	620-765 SSU @ 100F
Exxon Mobil	Mobil SHC Cibus 32	Mobil SHC Cibus 46	Mobil SHC Cibus 68	None listed	Mobil SHC Cibus 150
Petro Canada	Purity AW32	Purity AW46	Purity AW68	Purity AW100	None listed
Shell	Cassida Fluid HF 32	Cassida Fluid HF 46	Cassida Fluid HF 68	Cassida Fluid HF 100	None listed
Chevron	Lubricating Oil FM 32	Lubricating Oil FM 46	Lubricating Oil FM 68	Lubricating Oil FM 100	None listed
Ultrachem Inc. • Omnilube	FGH 2032 Synthetic	FGH 2046 Synthetic	FGH 2068 Synthetic	FGH 2100 Synthetic	FGH 2150 Synthetic

Table 6 Recommended Food Grade Greases (NSF HI)

Company	Grease
Exxon Mobil	Mobilgrease EAL 102
Keystone	Nevastane HT/AW2
Shell	Cassida Grease EPS 2
Petro-Canada	Purity FG 2

Table 7 Approximate Oil Sump Capacities

Frame Size	Motor Type Designation (See Motor Nameplate)	Oil Capacity (Quarts)	
		Upper Bearing	Lower Bearing
180 - 280	AU, AV-4	Grease	Grease
180 - 280	AV		
320 - 440	RV		
320 - 360	RV-4, RU	3	
400	RV-4, RU	5	
440	RV-4 (2 pole)	17	
	RV-4, RU (4 pole & slower)	6	
180 - 440	TV-9, TV, LV-9, LV	Grease	
180 - 360	TV-4, TU, LV-4, LU		
400	TV-4, TU, LV-4, LU	6	
440	TV-4, TU, LV-4, LU	5	
449	JU, JV-4	22	
	HU, HV-4	12	
	RU, RV4	24	
	JV-3, JV, HV	Grease	
HV, EV, JV, RV			
5000	RU, RV-4	30	
	HU, HV-4 (4 pole & slower)	12	
	HV-4 (2 pole only)	20	
	EU, JU, EV-4, JV-4	22	5
5808-5810	HU, HV-4	24	3
5807-5811	EU, JU, EV-4, JV-4	37	4
5812	JU, JV4	41	4
5813	RU, RV-4	48	4
6808-6810	HU, HV-4	70	3
6808-6810	HV (Bow Thruster)	Grease	Grease
6808-6810	HV (Other Than Bow Thruster)	70	3
6812	JU, JV4	48	7
6813	RU, RV4	48	7
8000	RU, RV-4	70	6
	RV	Grease	Grease
9600	RU, RV-4	95	13
	RV	Grease	Grease

X. Fundamental Troubleshooting - Problem Analysis

This chart can reduce work and time spent on motor analysis. Always check the chart first before starting motor disassembly, as what appears to be a motor problem may often be located elsewhere. For additional information, consult our website at www.usmotors.com.

SYMPTOM	POSSIBLE CAUSE	ANALYSIS
Motor fails to start	Defective power supply	Check voltage across all phases above disconnection switch
	Blown or defective primary fuses	
	Blown or defective secondary fuses	Check voltage below fuses (all phases) with disconnect closed
	Open control circuit	Push reset button
	Overload trips are open	
	Defective holding coil in magnetic switch	Push start button and allow sufficient time for operation of time and delay, if used, the check voltage across magnetic holding coil. If correct voltage is measured, coil is defective. If no voltage is measured, control circuit is open
	Loose or poor connections in control circuits	Make visual inspection of all connections in control switch
	Magnetic switch closes	Open manual disconnect switch, close magnetic by hand, and examine contractors and springs
	Poor switch closes	
	Opens circuit in control panel	Check voltage at T1, T2, & T3
	Open circuit leads to motor	Check voltage at leads in outlet box
Leads improperly connected	Check lead numbers and connections	
Motor fails to come up to speed	Low or incorrect voltage	Check voltage at T1, T2, & T3 in control panel and at motor leads in outlet box
	Incorrect connection at motor	Check for proper lead connections at motor and compare with connection diagram on motor
	Overload - Mechanical	Check impeller setting. Check for a tight or locked shaft
	Overload - Hydraulic	Check impeller setting. Check GPM against pump capacity and head
Motor Vibrates	Headshaft misaligned	Remove top drive coupling and check alignment of motor to pump
	Worn line shaft bearings or bent line shaft	Disconnect motor from pump and run motor only to determine source of vibration
	Hydraulic disturbance in discharge piping	Check isolation joint in discharge piping near pump head
	Ambient Vibration	Check base vibration level with motor stopped
	System Natural Frequency (Resonance)	Revise rigidity of support structure
Motor Noisy	Worn thrust bearing	Remove dust cover, rotate rotor by hand, and make visual examination of balls and races. Bearing noise is commonly accompanied by a high frequency vibration and/or increased temperature
	Electrical noise	Most motors are electrically noisy during the starting period. This noise should diminish as motor reaches full speed

SYMPTOM	POSSIBLE CAUSE	ANALYSIS
<p>Motor overheating (Check with thermocouple or by resistance methods. Do not depend on hand.)</p>	Overload	<p>Measure load and compare to nameplate rating. Check for excessive friction in motor or in complete drive. Reduce load or replace motor with greater capacity motor. Refer to Appendix C.</p>
	Motor intake or exhaust blocked or clogged	<p>Clean motor intake and exhaust areas. Clean filters or screens if motor is so equipped</p>
	Unbalanced voltage	<p>Check voltage to all phases. Refer to Appendix A</p>
	Open stator windings	<p>Disconnect motor from load. Check idle amps for balance in all three phases. Check stator resistance in all three phases</p>
	Over / Under Voltage	<p>Check voltage and compare to nameplate voltage</p>
	Ground	<p>Locate with test lamp or insulation tester and repair</p>
	Improper connections	<p>Re-check connections</p>
<p>Bearing Overheating</p> <p>Generally, bearing temperatures (as measured by a tipsensitive RTD or thermocouple touching the bearing outer race) should not exceed 90°C when using mineral-based lubricants or 120°C when using synthetic-based lubricants</p>	Misalignment	<p>Check alignment</p>
	Incorrect oil, or oil level too high or too low	<p>Refill with proper oil. Verify oil level is correct</p>
	Excessive thrust	<p>Reduce thrust from driven machine</p>
	Bearing over-greased	<p>Relieve bearing cavity of grease to level specified in lubrication section</p>
	Motor overloaded	<p>Measure load and compare to nameplate rating. Check for excessive friction in motor or in complete drive. Reduce load or replace motor with greater capacity motor. Refer to Appendix C.</p>
	Motor intake or exhaust blocked or clogged	<p>Clean motor intake and exhaust areas. Clean filters or screens if motor is so equipped</p>
<p>Bearing oil leaking around the drain plug</p>	<p>Insufficient sealant applied to drain plug threads</p>	<p>Remove drain plug and drain existing oil from sump. With a clean cloth, wipe excess oil from the plug threads and the threads in the drain hole. Apply Gasolia Thread Sealant P/N SS08 to the threads of the plug and replace. Fill sump with new oil to the proper level.</p>

XI. Spare Parts

A parts list is available for your unit and will be furnished upon request. Parts may be obtained from local Nidec Motor Corporation distributors and authorized service shops, or through Nidec Motor Corporation distribution center.

Nidec Motor Corporation
710 Venture Drive
Suite 100
Southaven, MS 38672
Phone (662) 342-6910
Fax (662) 342-7350

Drawings for many standard designs are supplied on the following pages. Most of the parts should be easy to identify. If however, there is some deviation from your machine, consult Nidec Motor Corporation Product Service Department.

XII. Index Cut Away Views and Explosion Views

Frame	Type	Page Number(s)
280, 320, 360	LU, TU	25
400 thru 440	LU, TU, TV-4, LV4 High Thrust	26
449	JV, JV3	27
449 (2 Pole)	JV4	28
449 (4 Pole and Slower)	JU and JV4	29
5800 (2 Pole)	JV4 and EV4	30
5807 thru 5811 (4 Pole and Slower)	JU, JV4, EU, EV4	31
5812	JU, JV4	32, 33
6812	JU, JV4 (6812)	34, 35, 36
250 thru 280	AU High Thrust	37
440 (2 Pole)	RV-4.....	38
320 thru 400	RU, High Thrust	39, 40, 41
440	RU, High Thrust	42, 43, 44, 45
320-440	RV.....	46
449	RU, R4 WPI	47, 48, 49, 50
449	RU, RV4 WP II	51, 52, 53, 54
5000-6800, 8000	HU, HV4 (5000, 6800, RU, RV4 8000)	55
5000 and 5800 WP II	RU, RV4	56, 57
5000 WP I	RU, RV4	58, 59, 60
6813	RU, RV4	61, 62, 63
9600	RU, RV4	64

280, 320, 360 Frames, Type LU
 320, 360 Frames, Type TU

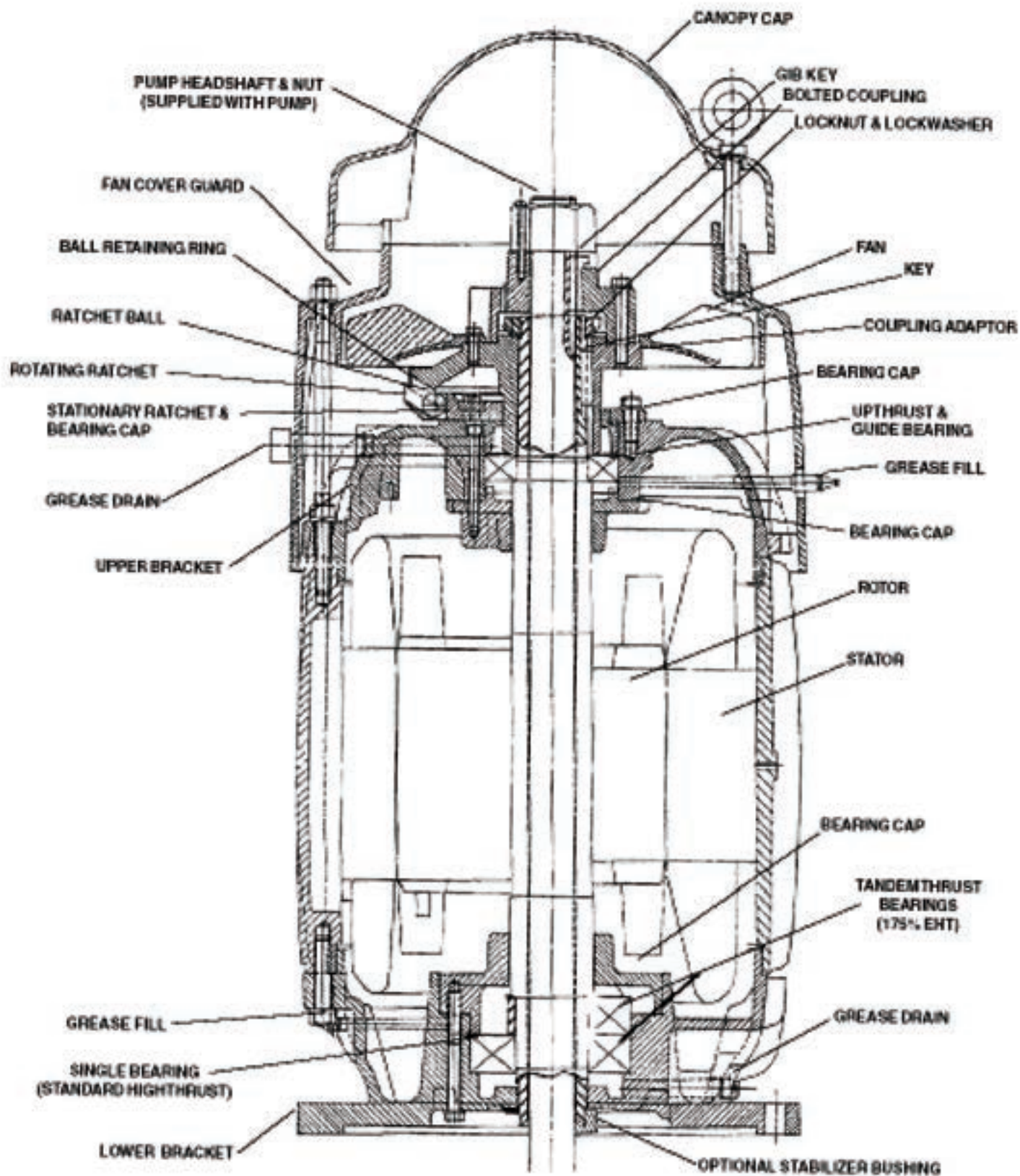

400 Thru 440 Frame Types TU, LU, TV-4 and LV-4 High Thrust

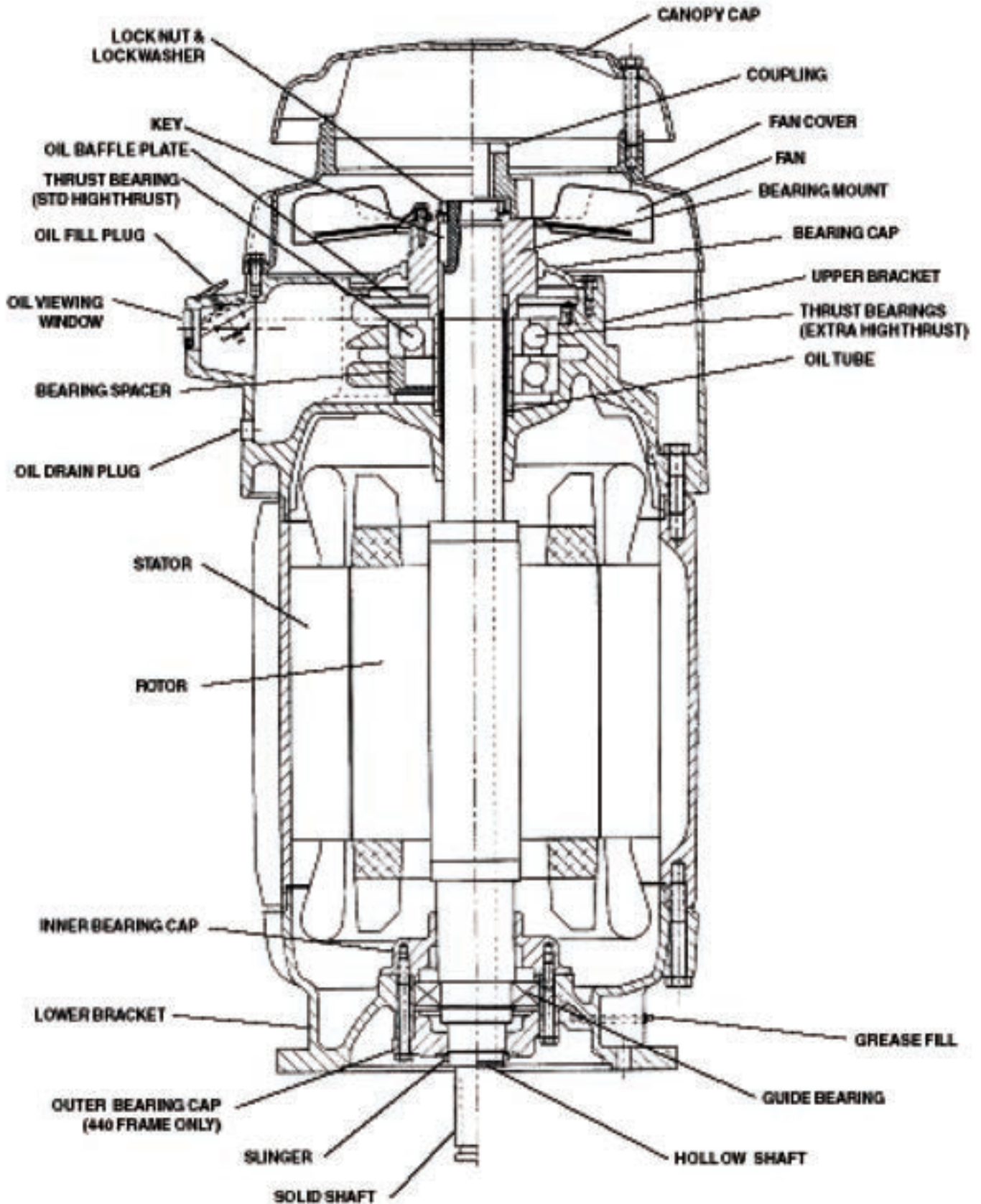

449 Frame Type JV & JV-3

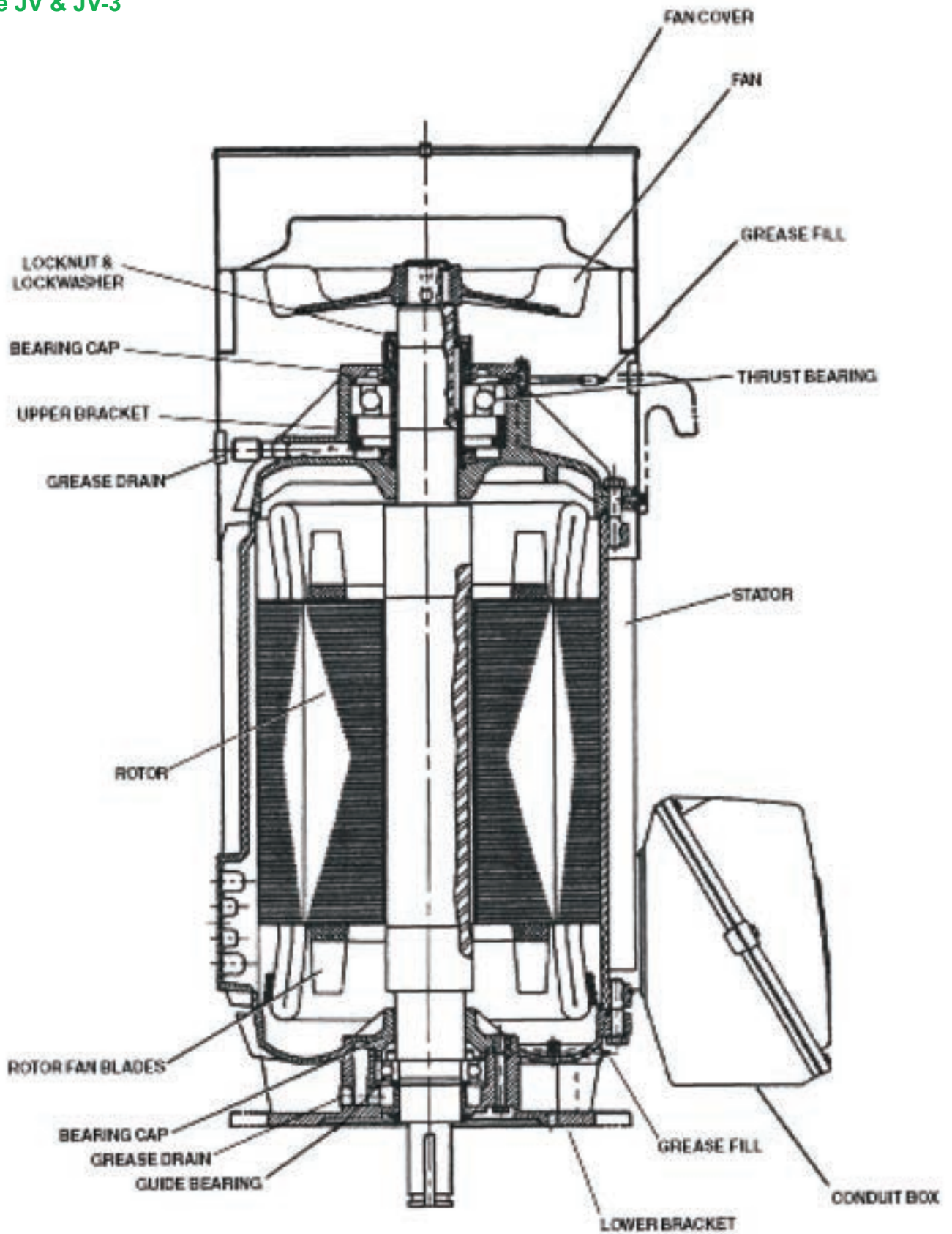

449 Frame
Type JV-4 (2 Pole)

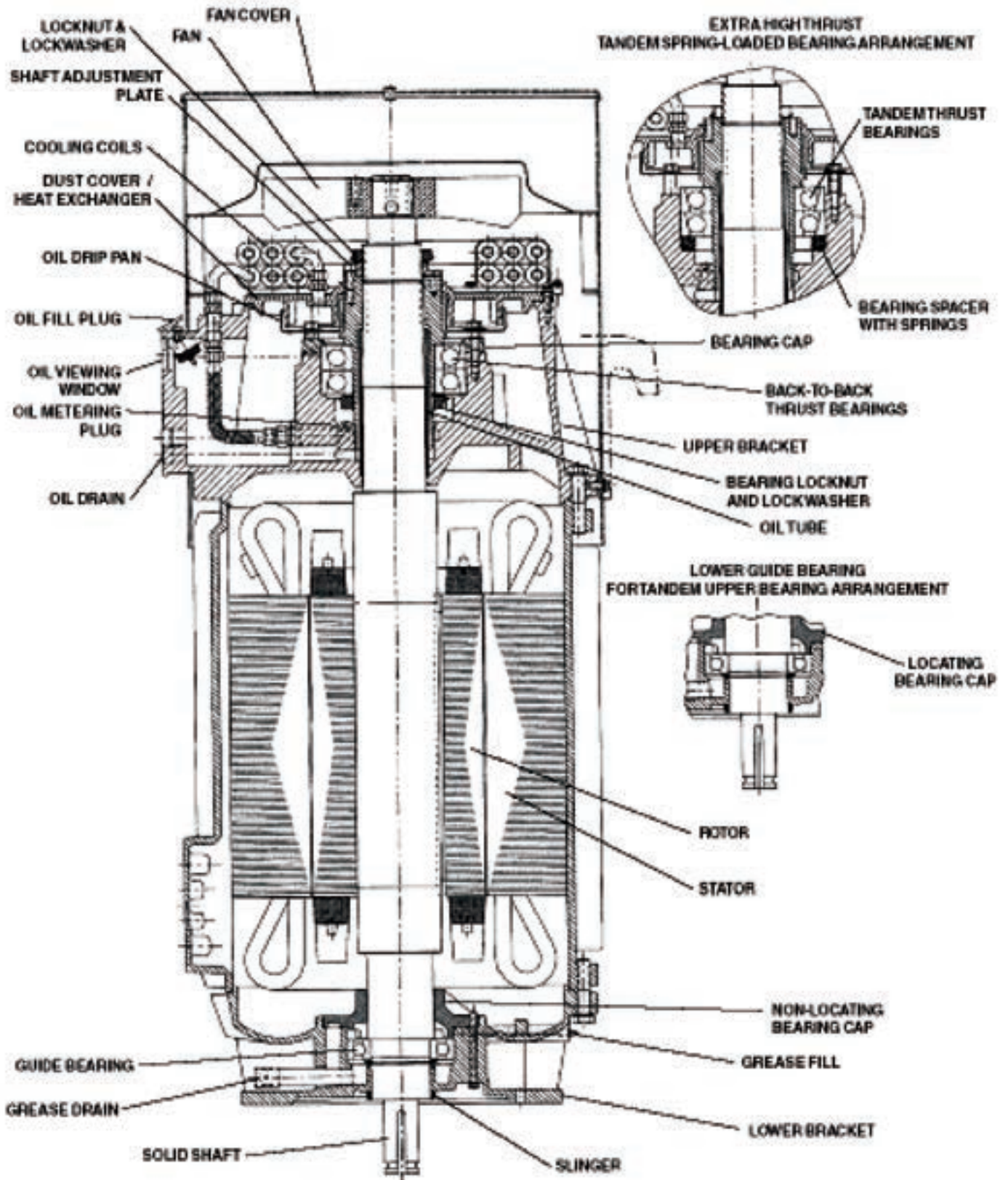

449 Frame Type JU and JV-4 (4 Pole & Slower)

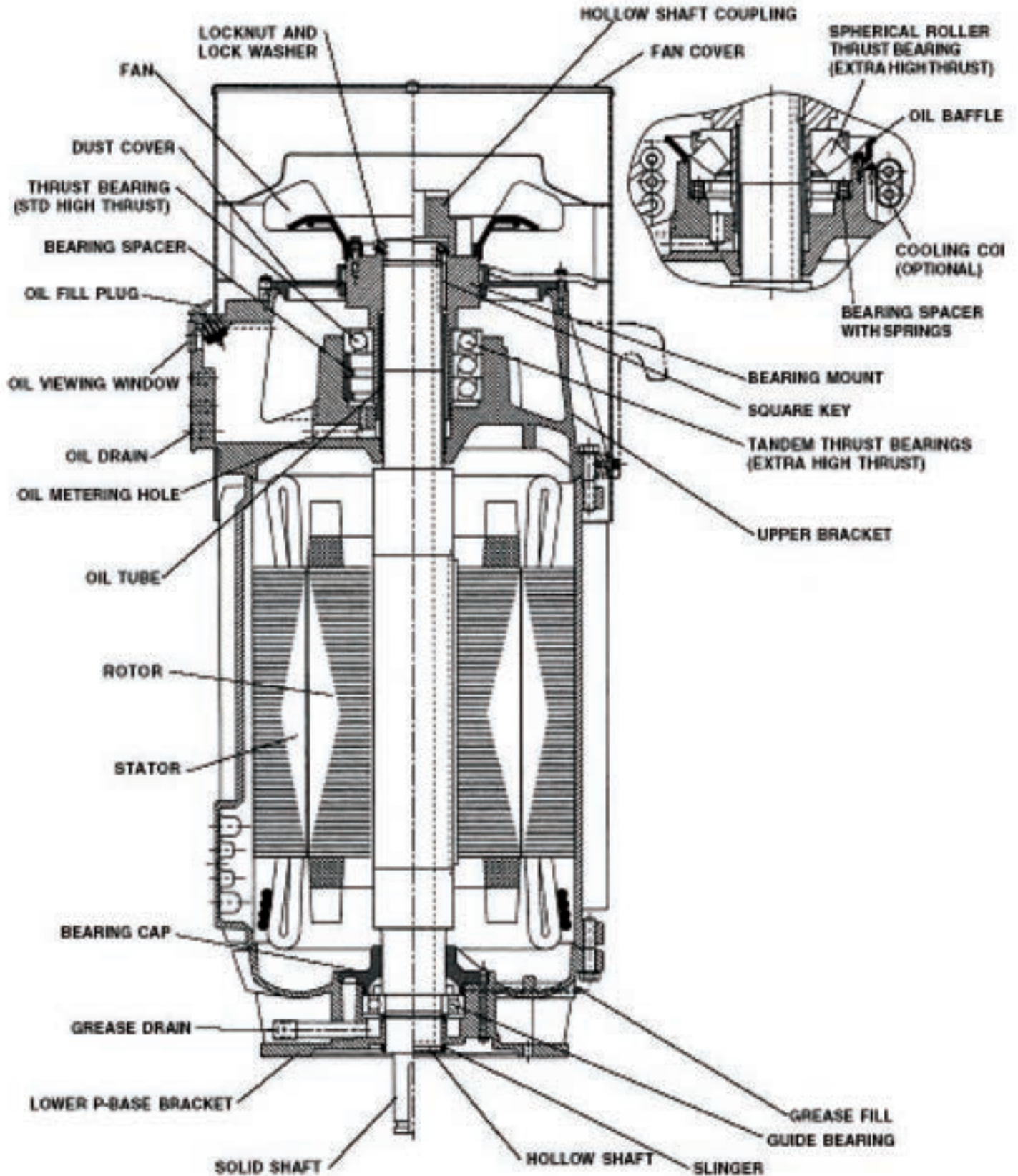

5800 Frame JV-4 & EV-4 (2 Pole)

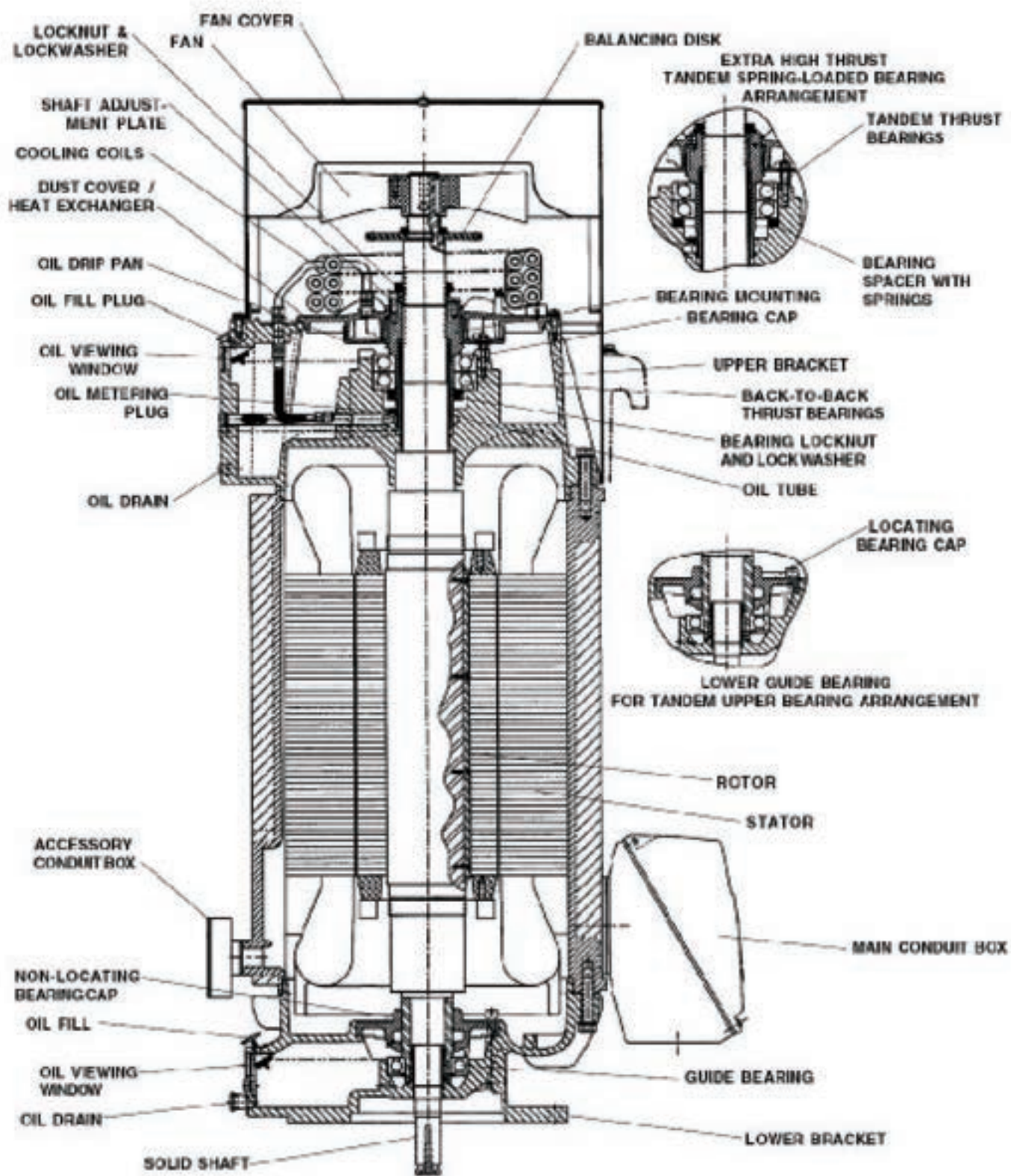

5807 - 5811 Frame
 Type JU, and JV-4, EU, EV-4 (4 Pole & Slower)

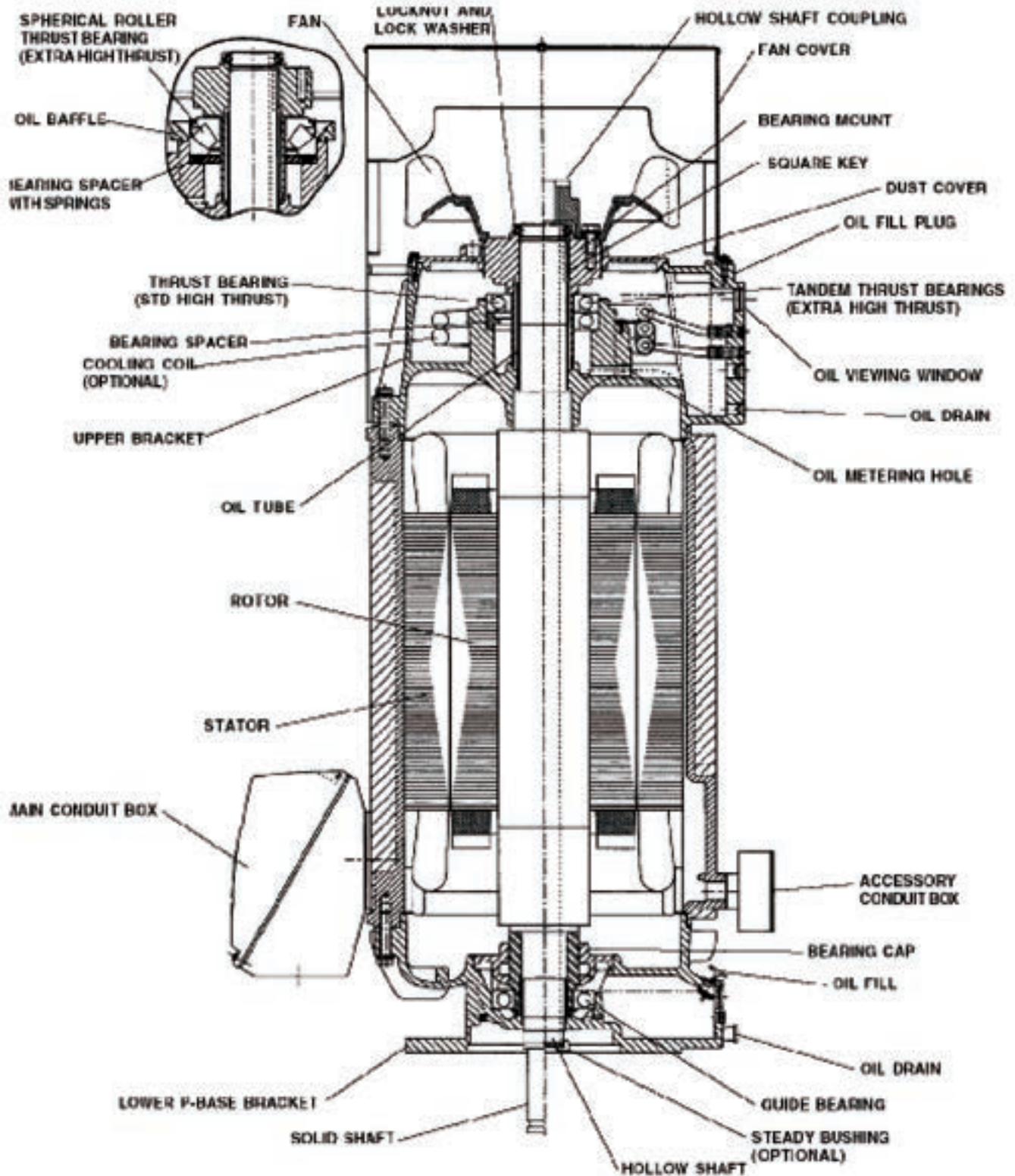

5812 Frame Type JU, JV4

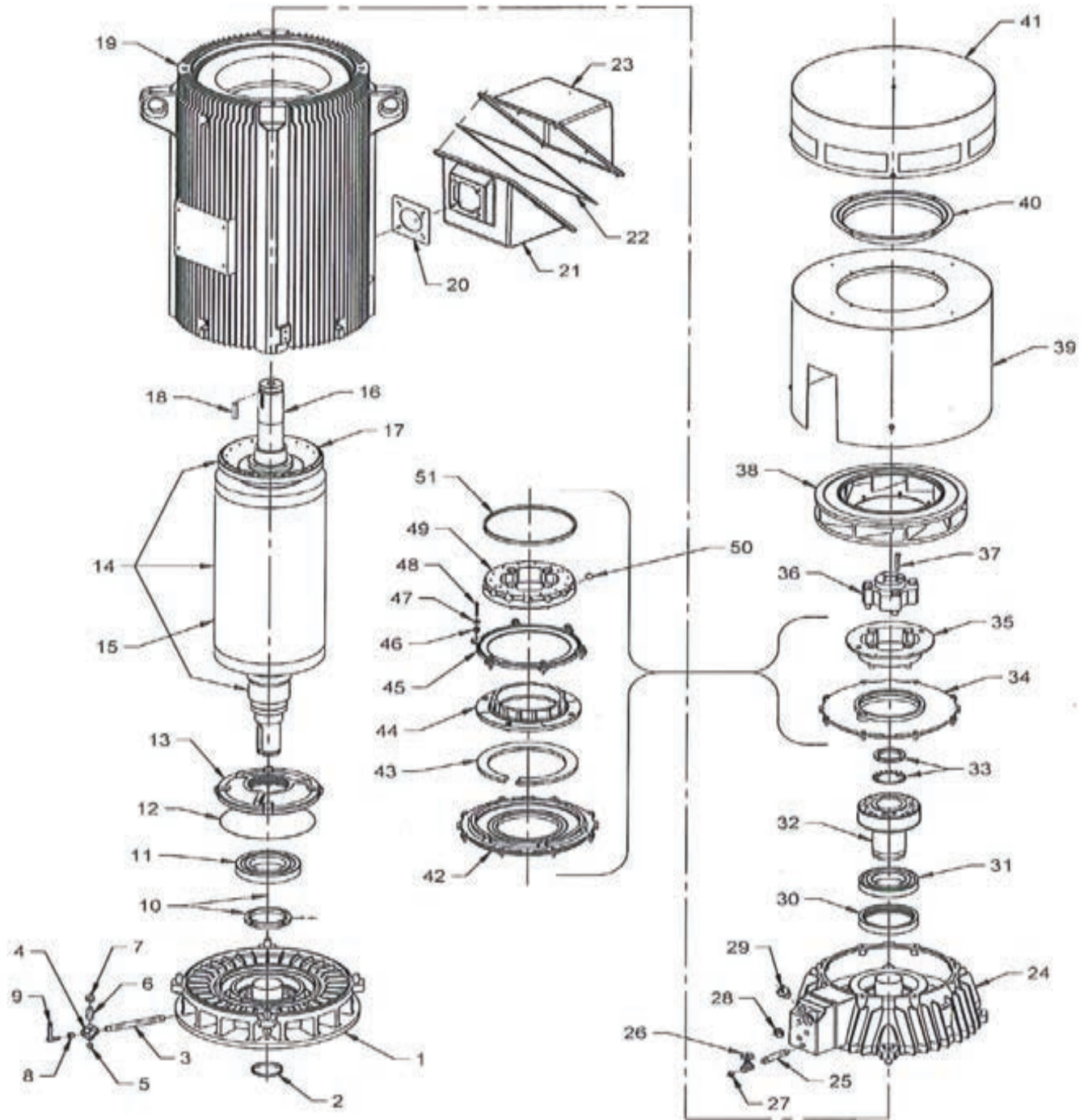

5812 Frame Type JU, JV4

ITEM NO.	QTY	NAME OF PART	ITEM NO.	QTY	NAME OF PART
1	1	Lower Bracket	28	1	Oil Sight Gauge Window
2	1	Shaft Water Slinger	29	1	Oil Fill Plug (Expanding)
3	1	Pipe Nipple (Lower Oil Drain)	30	1	Bearing Spacer (or Tandem Thrust Bearing)
4	1	Pipe Tee (Lower Oil Drain)	31	1	Upper Thrust Bearing
5	1	Pipe Plug (Lower Oil Drain)	32	1	Bearing Mounting
6	1	Pipe Nipple (Lower Oil Fill)	33	1	Locknut and Lockwasher (Brg Mtg to Shaft)
7	1	Pipe Cap (Lower Oil Fill)	34	1	Dust Cover (Only on Units Without Ratchet)
8	1	Reducer Bushing	35	1	Fan Adaptor (Only on Units Without Ratchet)
9	1	Oil Sight Gauge Window	36	1	Thrust Coupling (Only on Hollowshaft)
10	1	Locknut and Set Screws	37	1	Gib Key (Only on Hollowshaft)
11	1	Lower Bearing	38	1	Fan
12	1	O-Ring	39	1	Fan Cover
13	1	Lower Bearing Cap	40	1	Air Deflector
14	1	Rotor Assembly	41	1	Canopy Cap
15	1	Rotor Core	42	1	Ratchet Adaptor (Only on Units With Ratchet)
16	1	Rotor Shaft	43	1	Connection Spring (Only on Units With Ratchet)
17	1	Rotor Fan	44	1	Stationary Ratchet (Only on Units With Ratchet)
18	1	Square Key (Bearing Mounting to Shaft)	45	1	Pressure Plate (Only on Units With Ratchet)
19	1	Stator Assembly	46	6	Die Spring (Only on Units With Ratchet)
20	1	Gasket (Outlet Box Base to Stator)	47	6	Plain Washer (Only on Units With Ratchet)
21	1	Outlet Box Base	48	6	Screw (Only on Units With Ratchet)
22	1	Gasket (Outlet Box Cover to Base)	49	1	Rotating Ratchet (Only on Units With Ratchet)
23	1	Outlet Box Cover	50	14	Ratchet Ball (Only on Units With Ratchet)
24	1	Upper Bracket	51	1	Ball Retaining Ring (Only on Units With Ratchet)
25	1	Pipe Nipple (Upper Oil Drain)			
26	1	Gate Valve (Upper Oil Drain)			
27	1	Pipe Plug (Upper Oil Drain)			

6812 Frame Type JU and JV4

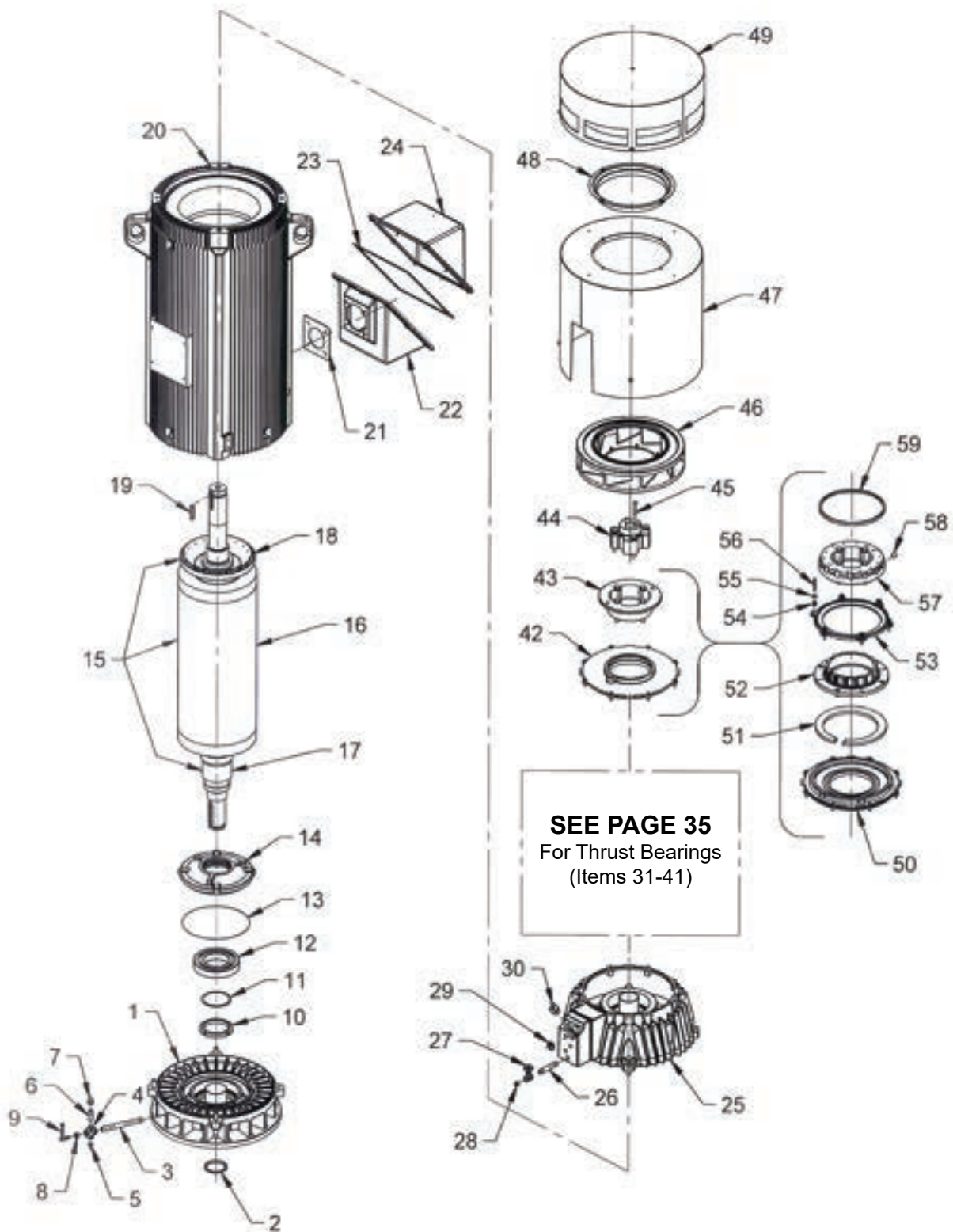

5812 and 6812 Frame Type JU and JV4

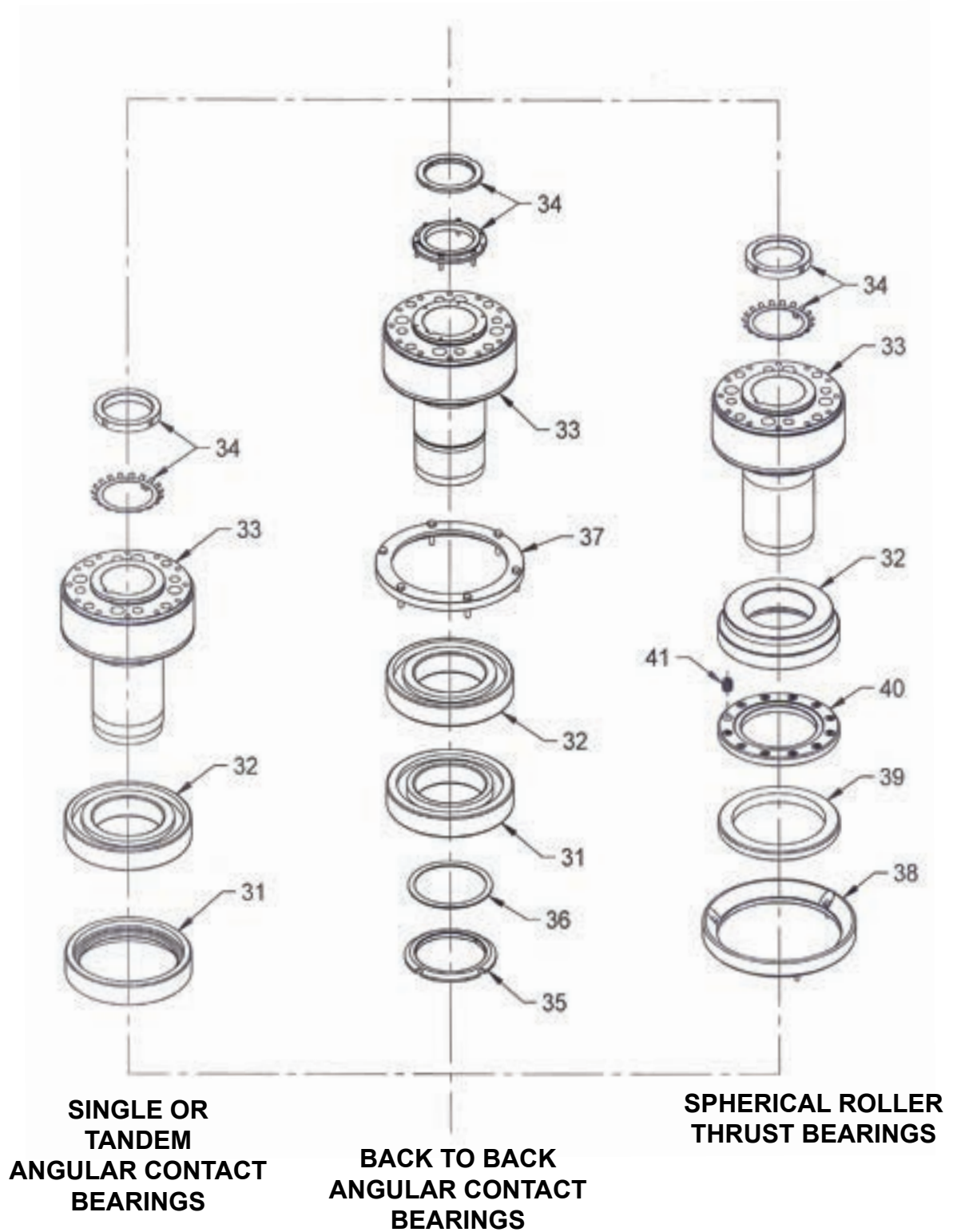
THRUST BEARING DETAILS

5812 Frame Type JU, and JV4 6812 Frame Type JU and JV4

ITEM NO.	QTY	NAME OF PART
1	1	Lower Bracket
2	1	Shaft Water Slinger
3	1	Pipe Nipple (Lower Oil Drain)
4	1	Pipe Tee (Lower Oil Drain)
5	1	Pipe Plug (Lower Oil Drain)
6	1	Pipe Nipple (Lower Oil Fill)
7	1	Pipe Cap (Lower Oil Fill)
8	1	Reducer Bushing
9	1	Oil Sight Gauge Window
10	1	Locknut and Set Screws
11	1	Insulated Washer (When Supplied)
12	1	Lower Bearing
13	1	O-Ring
14	1	Lower Bearing Cap
15	1	Rotor Assembly
16	1	Rotor Core
17	1	Rotor Shaft
18	1	Rotor Fan
19	1	Square Key (Bearing Mounting to Shaft)
20	1	Stator Assembly
21	1	Gasket (Outlet Box Base to Stator)
22	1	Outlet Box Base
23	1	Gasket (Outlet Box Cover to Base)
24	1	Outlet Box Cover
25	1	Upper Bracket
26	1	Pipe Nipple (Upper Oil Drain)
27	1	Gate Valve (Upper Oil Drain)
28	1	Pipe Plug (Upper Oil Drain)
29	1	Oil Sight Gauge Window
30	1	Oil Fill Plug (Expanding)

ITEM NO.	QTY	NAME OF PART
31	1	Bearing Spacer (or Tandem Thrust Bearing)
32	1	Upper Thrust Bearing
33	1	Bearing Mounting
34	1	Locknut and Lockwasher (Brg Mtg to Shaft)
35	1	Locknut and Set Screws (Back-to-Back Brgs.)
36	1	Bearing Spacer (Insul.)(Back-to-Back Brgs.)
37	1	Bearing Cap (Clamping)(Back-to-Back Brgs.)
38	1	Oil Baffle (EHT Bearing)
39	1	Bearing Support (EHT Bearing)(When Supplied)
40	1	Bearing Spacer (EHT Bearing)
41	As Req'd	Die Spring (EHT Bearing)
42	1	Dust Cover (Only on Units Without Ratchet)
43	1	Fan Adaptor (Only on Units Without Ratchet)
44	1	Thrust Coupling (Only on Hollowshaft)
45	1	Gib Key (Only on Hollowshaft)
46	1	Fan
47	1	Fan Cover
48	1	Air Deflector
49	1	Canopy Cap
50	1	Ratchet Adaptor (Only on Units With Ratchet)
51	1	Connection Spring (Only on Units With Ratchet)
52	1	Stationary Ratchet (Only on Units With Ratchet)
53	1	Pressure Plate (Only on Units With Ratchet)
54	6	Die Spring (Only on Units With Ratchet)
55	6	Plain Washer (Only on Units With Ratchet)
56	6	Screw (Only on Units With Ratchet)
57	1	Rotating Ratchet (Only on Units With Ratchet)
58	As Req'd	Ratchet Ball (Only on Units With Ratchet)
59	1	Ball Retaining Ring (Only on Units With Ratchet)

250 and 280 Frames Type AU High Thrust

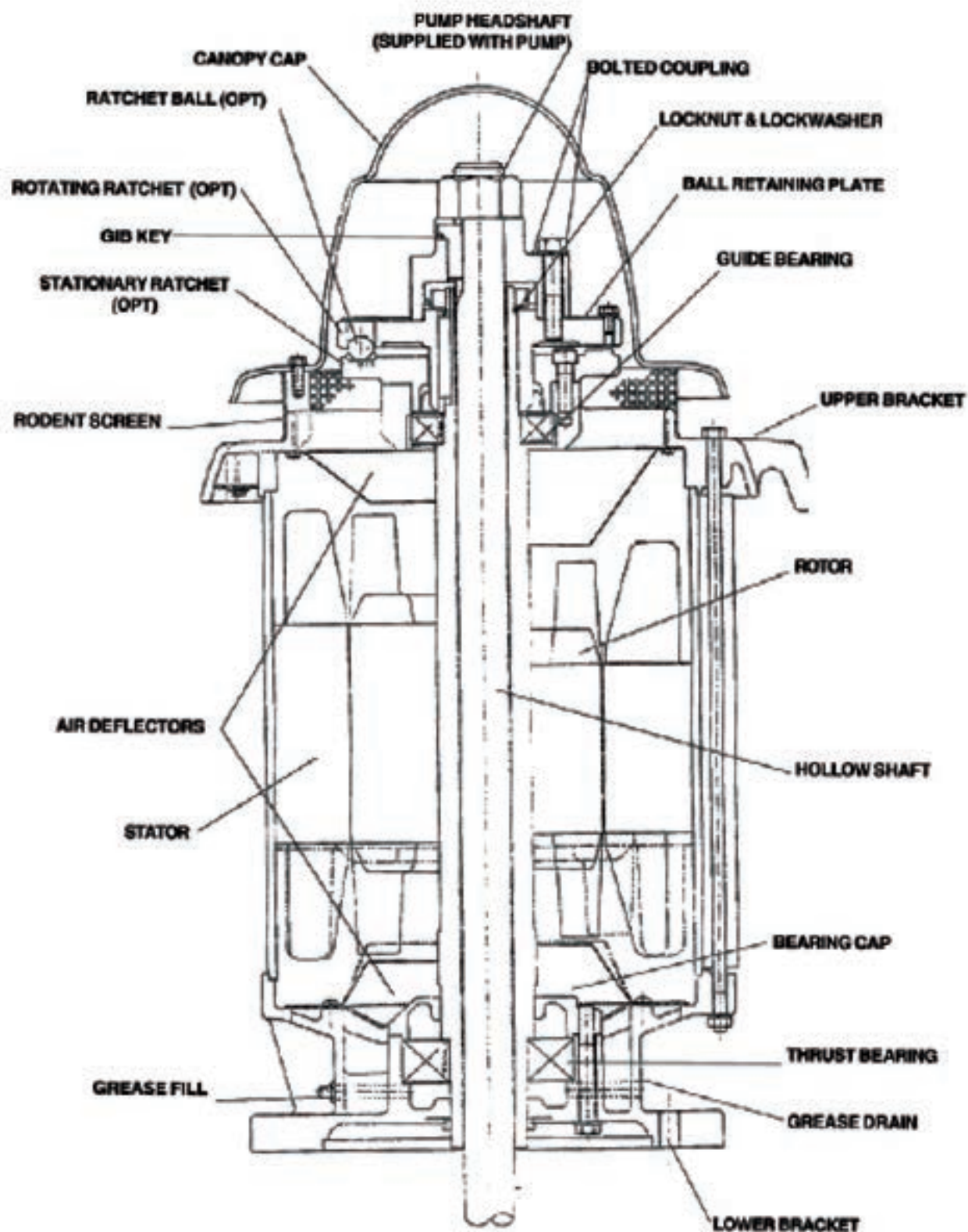

440 Frame, Type RV-4 (2 Pole)

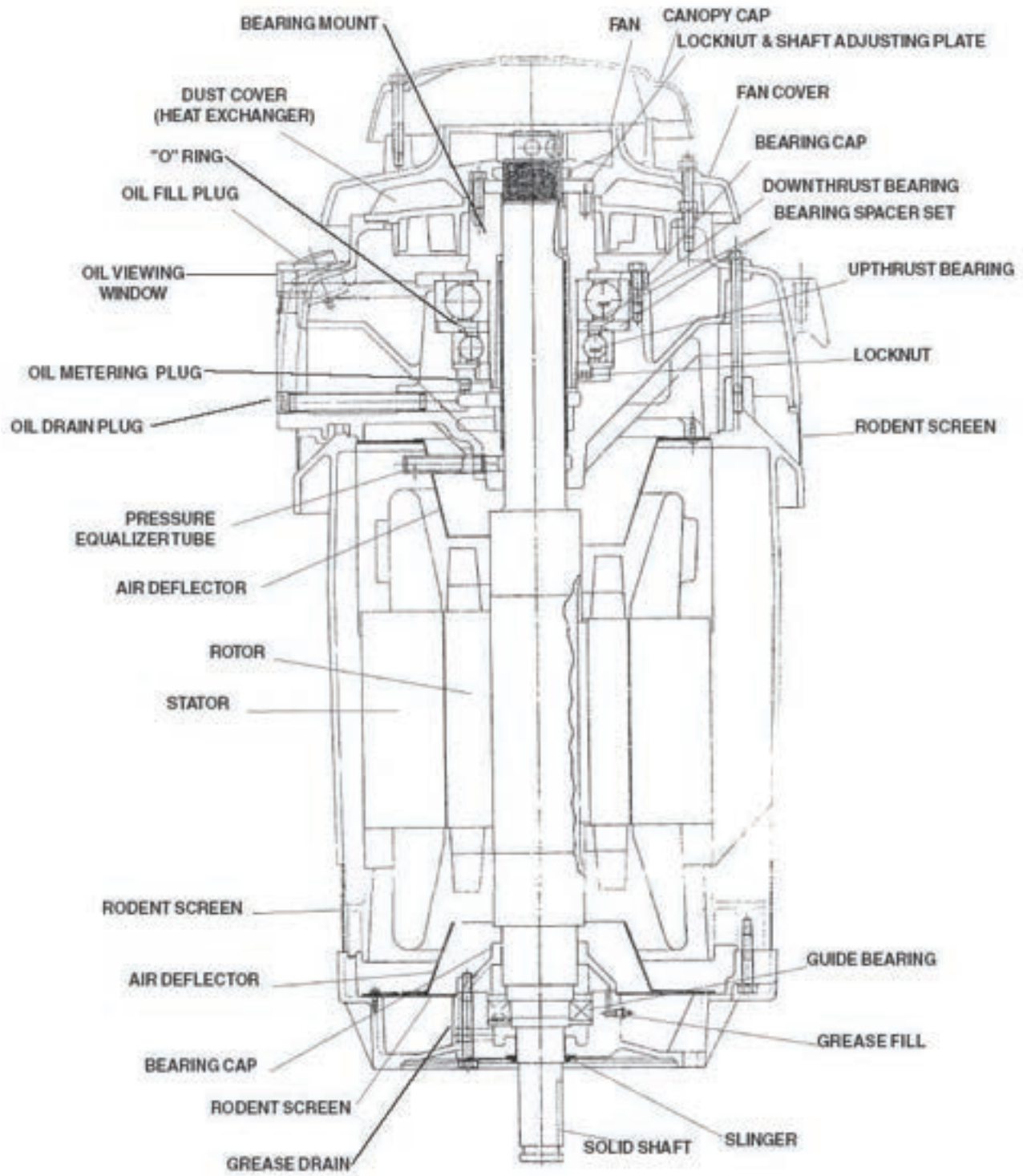

320 Thru 440 Frames Type RU - High Thrust

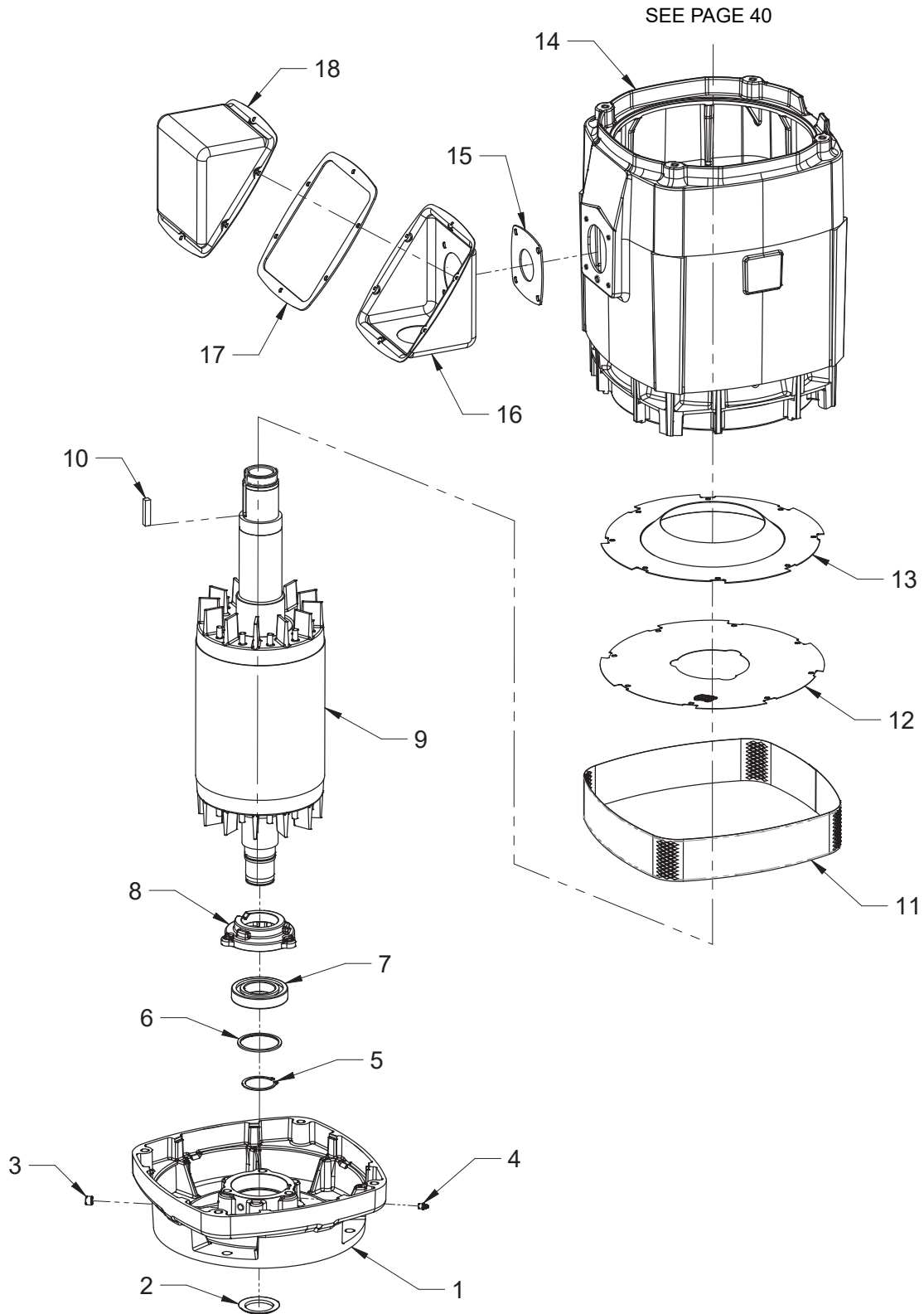

320 Thru 400 Frames Type RU - High Thrust

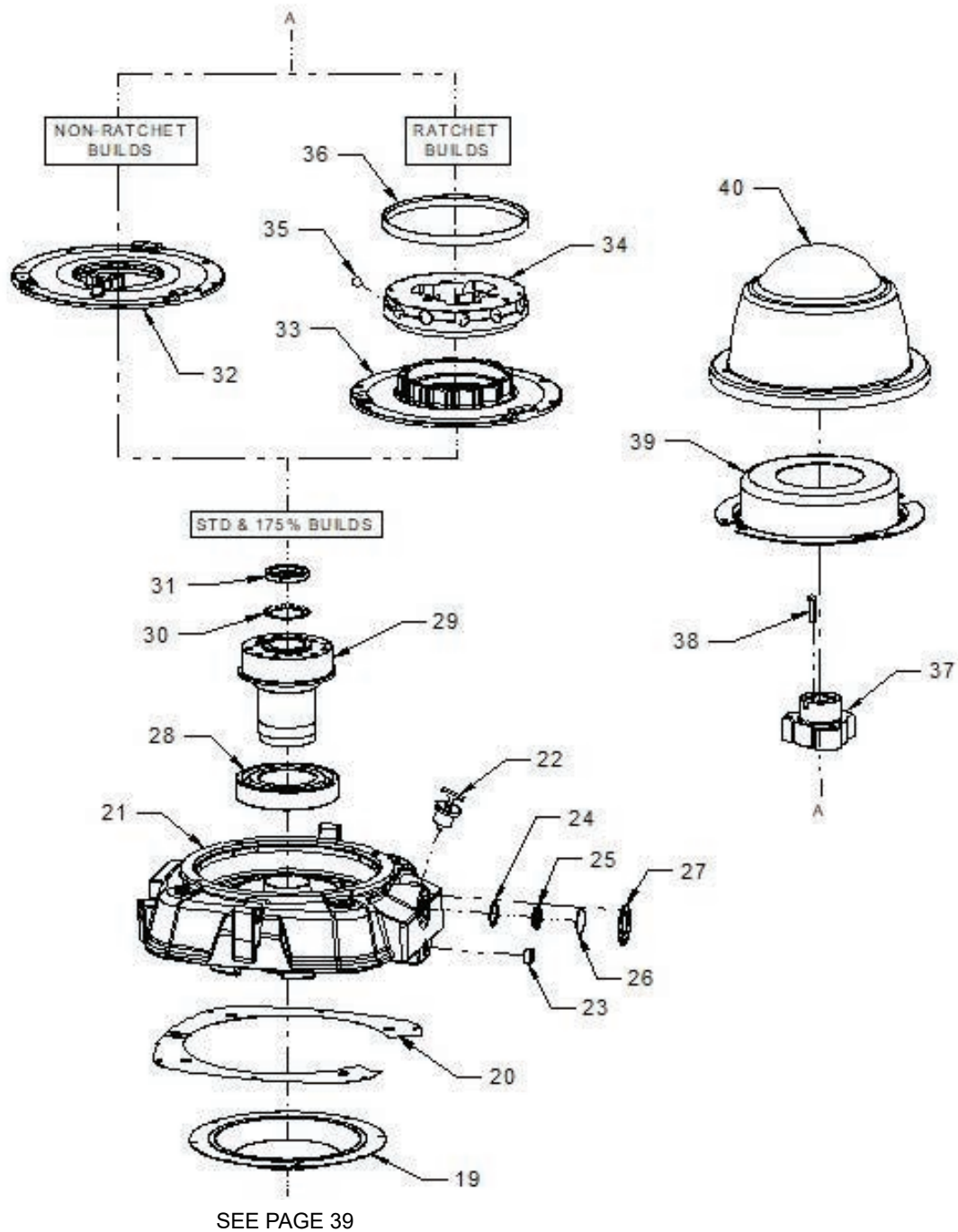

320 Thru 400 Frames Type RU - High Thrust

ITEM NO.	QTY	NAME OF PART
1	1	Lower Bracket
2	1	Water Deflector
3	1	Pipe Plug
4	1	Zerk Fitting Grease
5	1	Spacer Washer
6	1	Snap Ring
7	1	Lower Bearing
8	1	Lower Bearing Cap
9	1	Rotor Assembly
10	1	Key
11	1	Lower Screen Intake (External)
12	1	Lower Screen Intake (Internal)
13	1	Lower Air Deflector
14	1	Stator Assembly
15	1	Gasket Outlet Box (Frame and Box)
16	1	Outlet Base
17	1	Gasket Outlet Box (Base and Cover)
18	1	Cover Outlet Box
19	1	Upper Air Deflector
20	1	Upper Screen

ITEM NO.	QTY	NAME OF PART
21	1	Upper Bracket
22	1	Oil Fill Plug (Expanding)
23	1	Upper Plug (Oil Drain)
24	1	O-Ring Sight Gauge Window
25	1	Deflector Sight Gauge Window
26	1	Glass Sight Gauge Window
27	1	Cover Sight Gauge Window
28	-	Upper Bearing (Qty 1 or 2)
29	1	Bearing Mount
30	1	Upper Lockwasher
31	1	Upper Lock Nut
32	1	Dust Cover (Only on Units Without Ratchet)
33	1	Ratchet Adaptor (Only on Units With Ratchet)
34	1	Stationary Ratchet (Only on Units With Ratchet)
35	1	Ratchet Ball (Only on Units With Ratchet)
36	1	Ball Retaining Ring (Only on Units With Ratchet)
37	1	Thrust Coupling (Only on Hollowshaft)
38	1	Gib Key (Only on Hollowshaft)
39	1	Upper Baffle
40	1	Canopy Cap

440 Frame Type RU - High Thrust

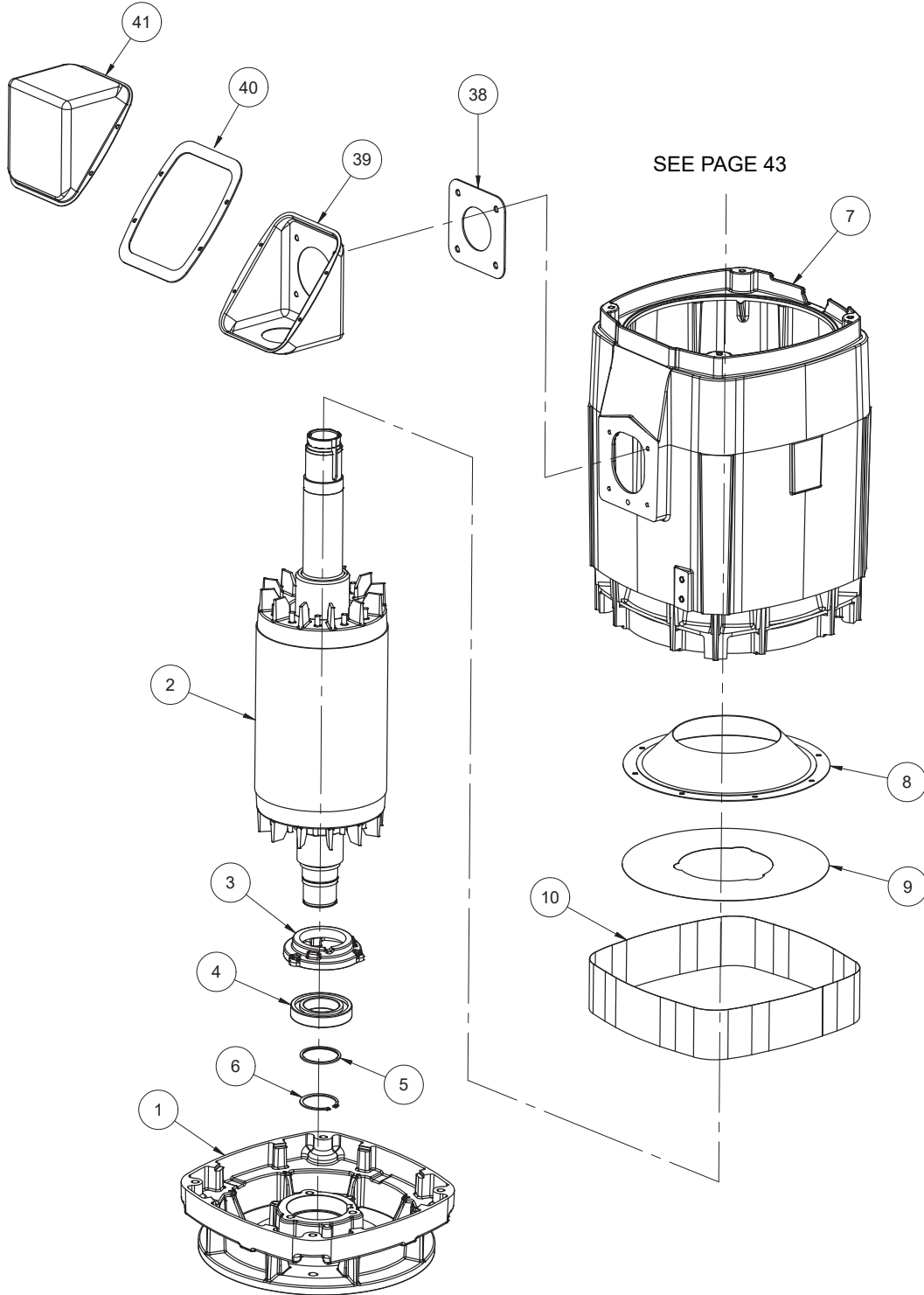

440 Frame Type RU - High Thrust

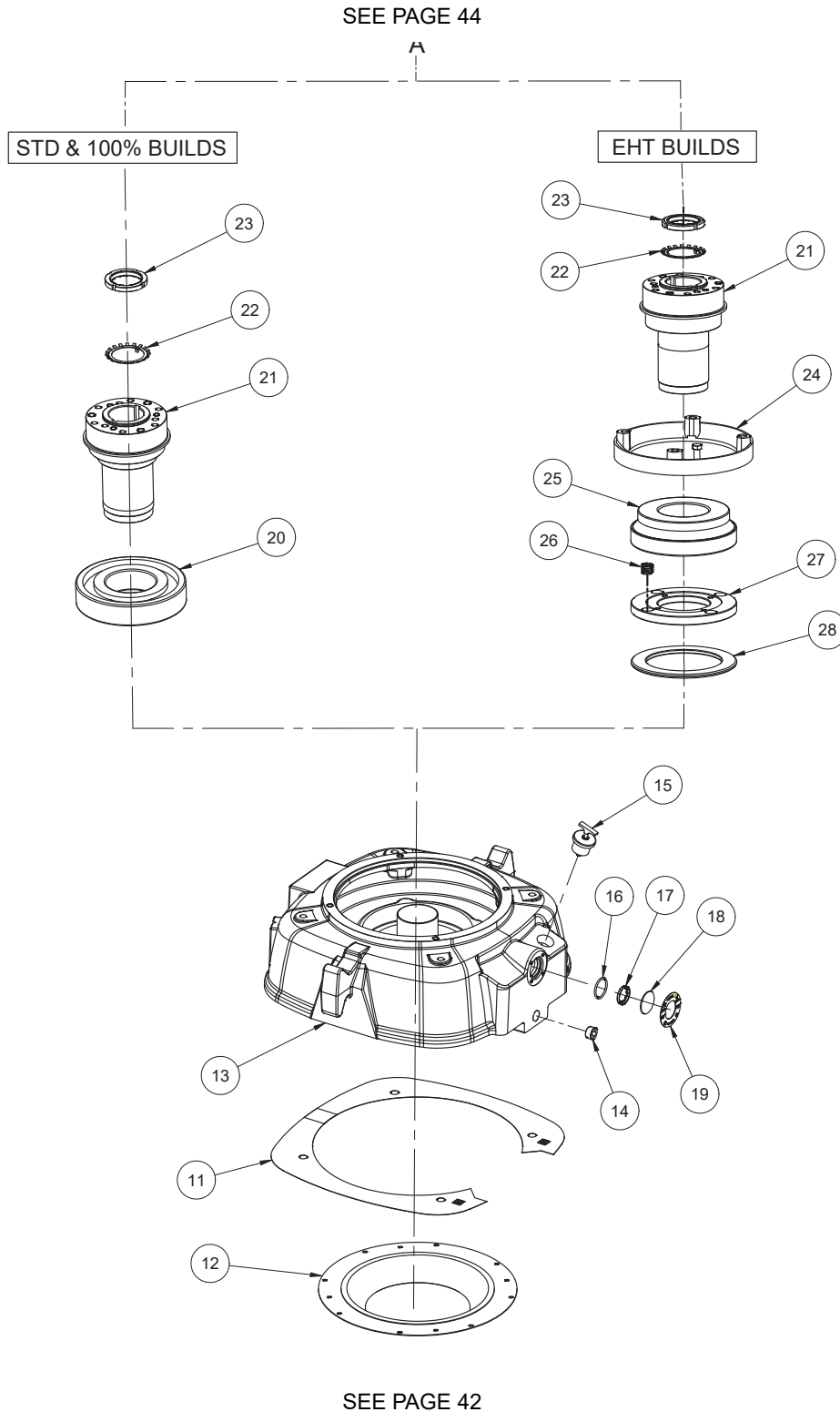

440 Frame Type RU - High Thrust

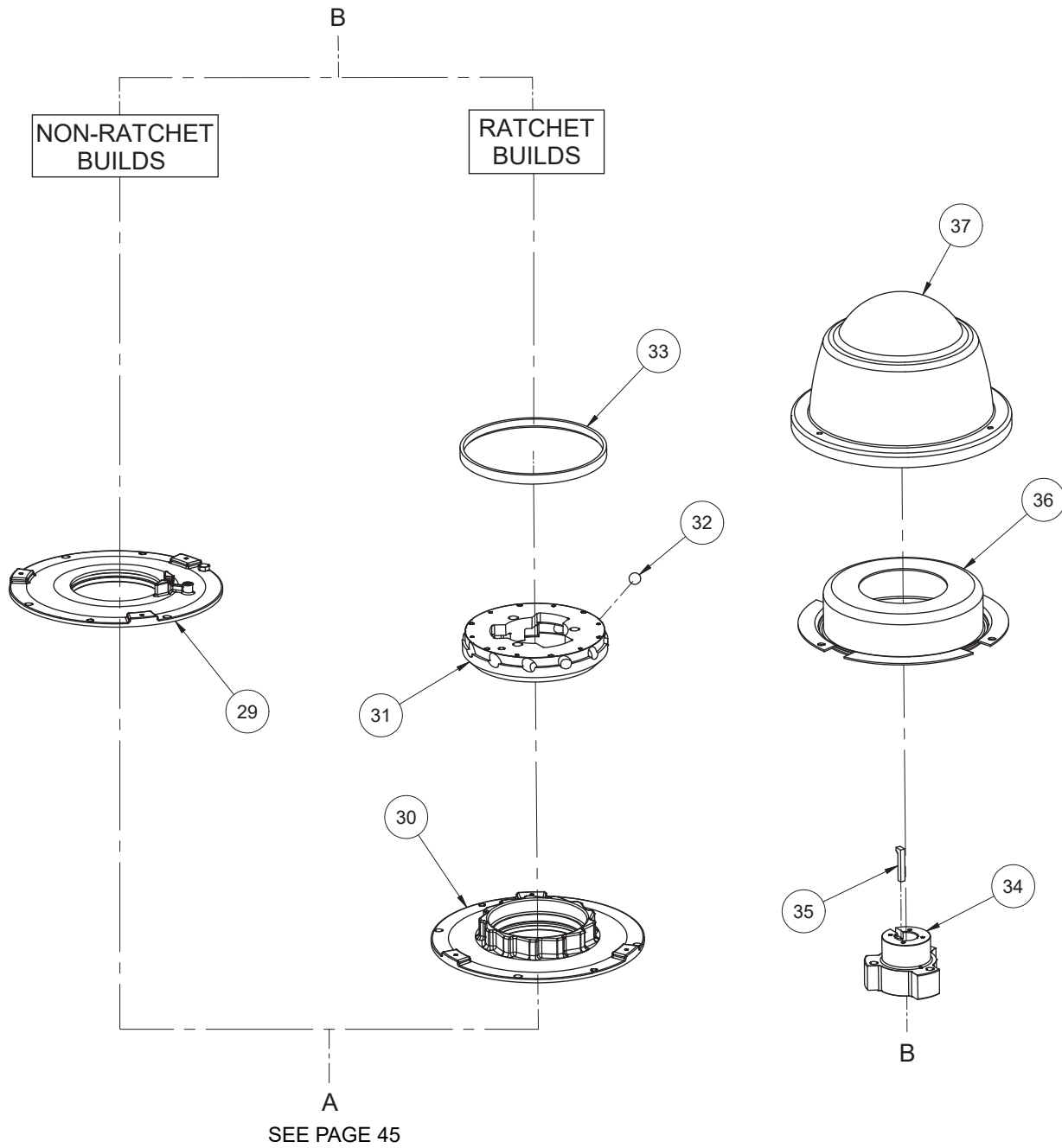

440 Frame Type RU - High Thrust

ITEM NO.	QTY	NAME OF PART
1	1	Lower Bracket
2	1	Rotor Assembly
3	1	Lower Bearing Cap
4	1	Lower Bearing
5	1	Spacer washer
6	1	Snap Ring
7	1	Stator Assembly
8	1	Lower Air Deflector
9	1	Lower Screen Intake (Internal)
10	1	Lower Screen Intake (External)
11	1	Upper Screen
12	1	Upper Air Deflector
13	1	Upper Bracket
14	1	Upper Plug (Oil Drain)
15	1	Oil Fill Plug (Expanding)
16	1	O-Ring Sight Gauge Window
17	1	Deflector Sight Gauge Window
18	1	Glass Sight Gauge Window
19	1	Cover Sight Gauge Window

ITEM NO.	QTY	NAME OF PART
20	-	Upper Bearing (Qty 1 or 2)
21	1	Bearing Mount
22	1	Upper Lockwasher
23	1	Upper Lock Nut
24	1	Oil Baffle (EHT Bearing)
25	1	Upper Thrust Bearing (EHT)
26	As Req'd	Die Spring (EHT Bearing)
27	1	Bearing Spacer (EHT Bearing)
28	1	Bearing Support (EHT Bearing)
29	1	Dust Cover (Only on Units Without Ratchet)
30	1	Ratchet Adaptor (Only on Units With Ratchet)
31	1	Stationary Ratchet (Only on Units With Ratchet)
32	1	Ratchet Ball (Only on Units With Ratchet)
33	1	Ball Retaining Ring (Only on Units With Ratchet)
34	1	Thrust Coupling (Only on Hollowshaft)
35	1	Gib Key (Only on Hollowshaft)
36	1	Upper Baffle
37	1	Canopy Cap
38	1	Gasket Outlet Box (Frame and Box)
39	1	Outlet Base
40	1	Gasket Outlet Box (Base and Cover)
41	1	Cover Outlet Box

320 - 440 Frame Type RV - Normal Thrust

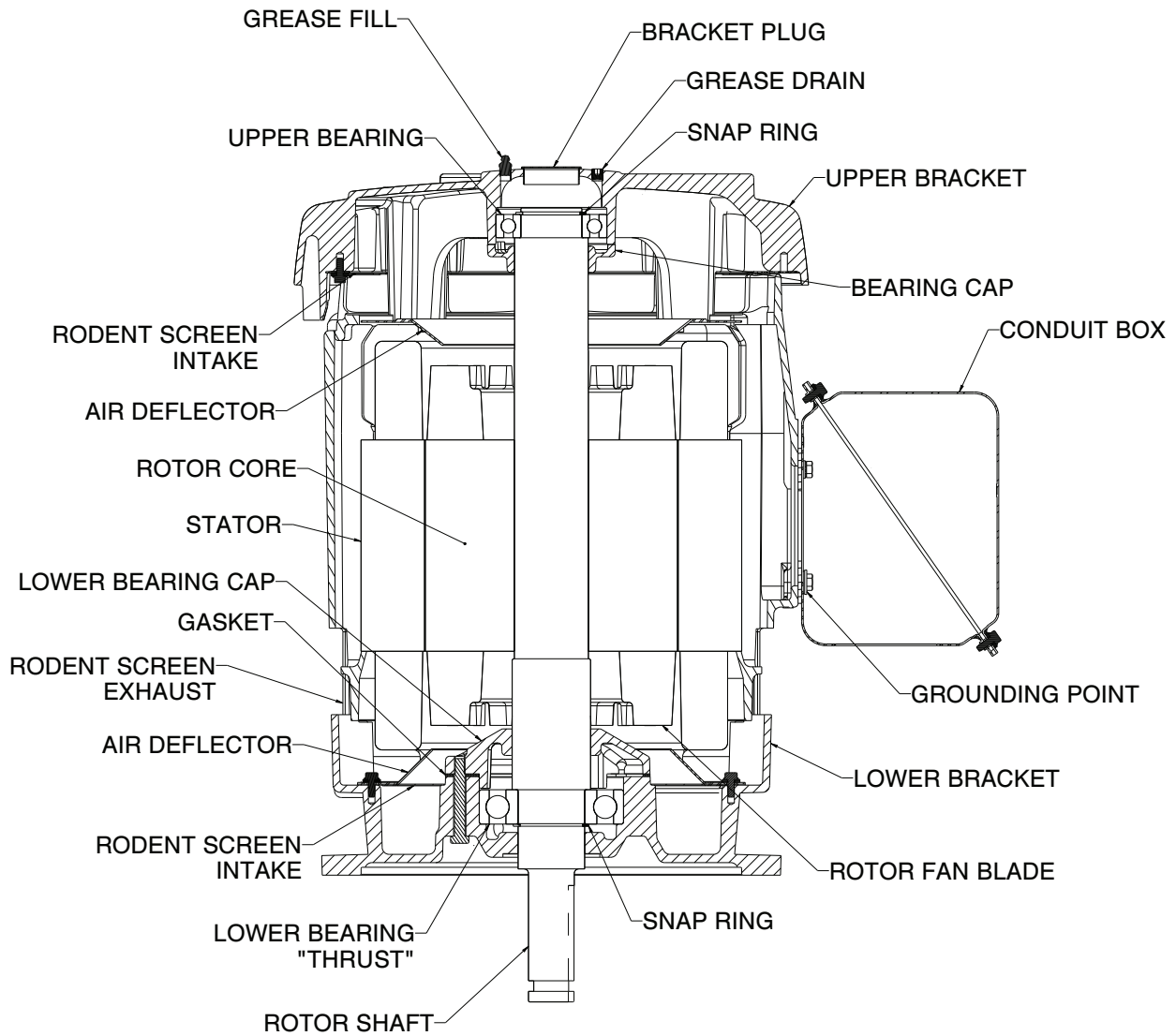

**449 Frame (WPI)
Type RU and RV4**

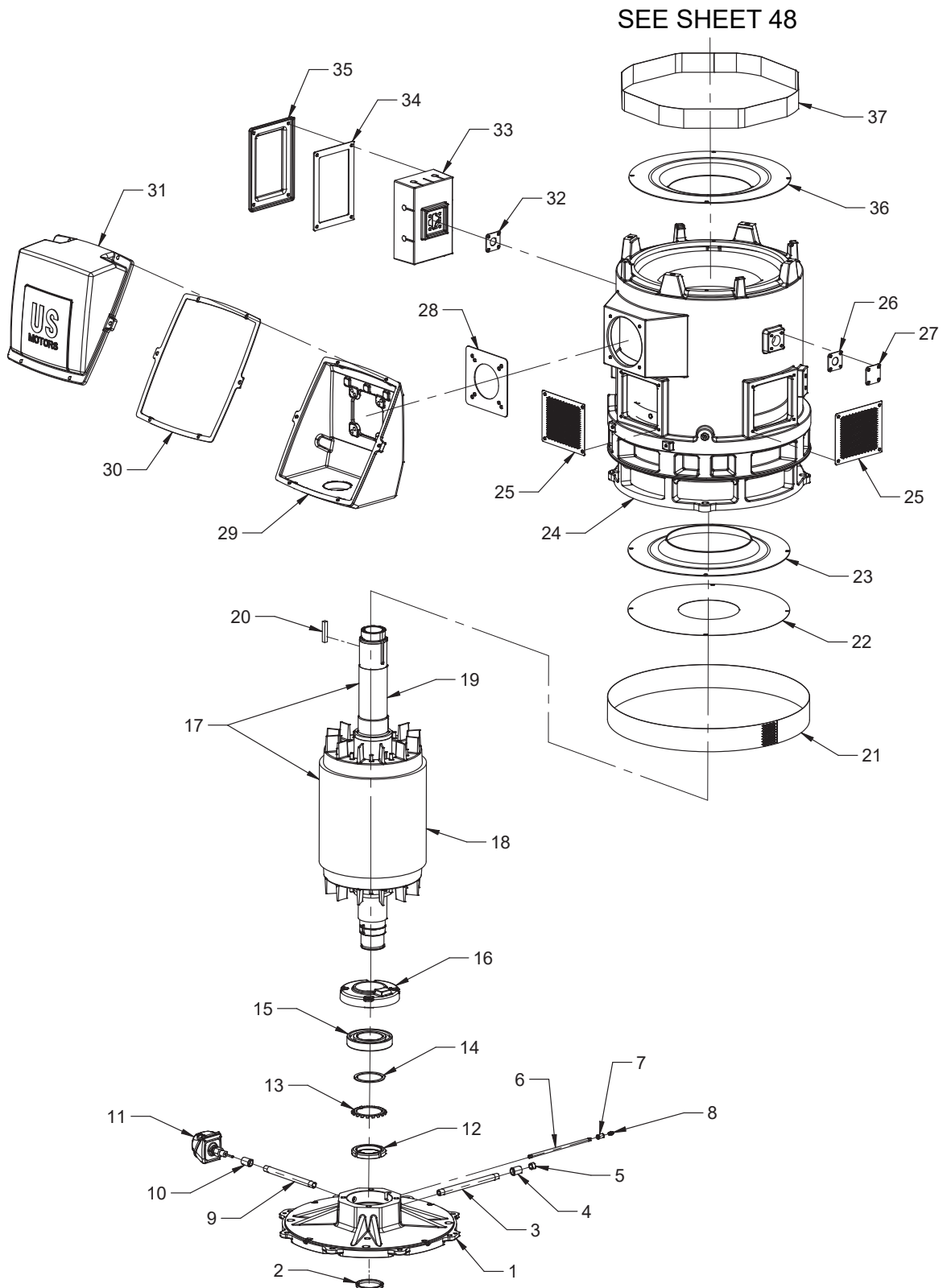

449 Frame (WPI) Type RU and RV4

SEE SHEET 49

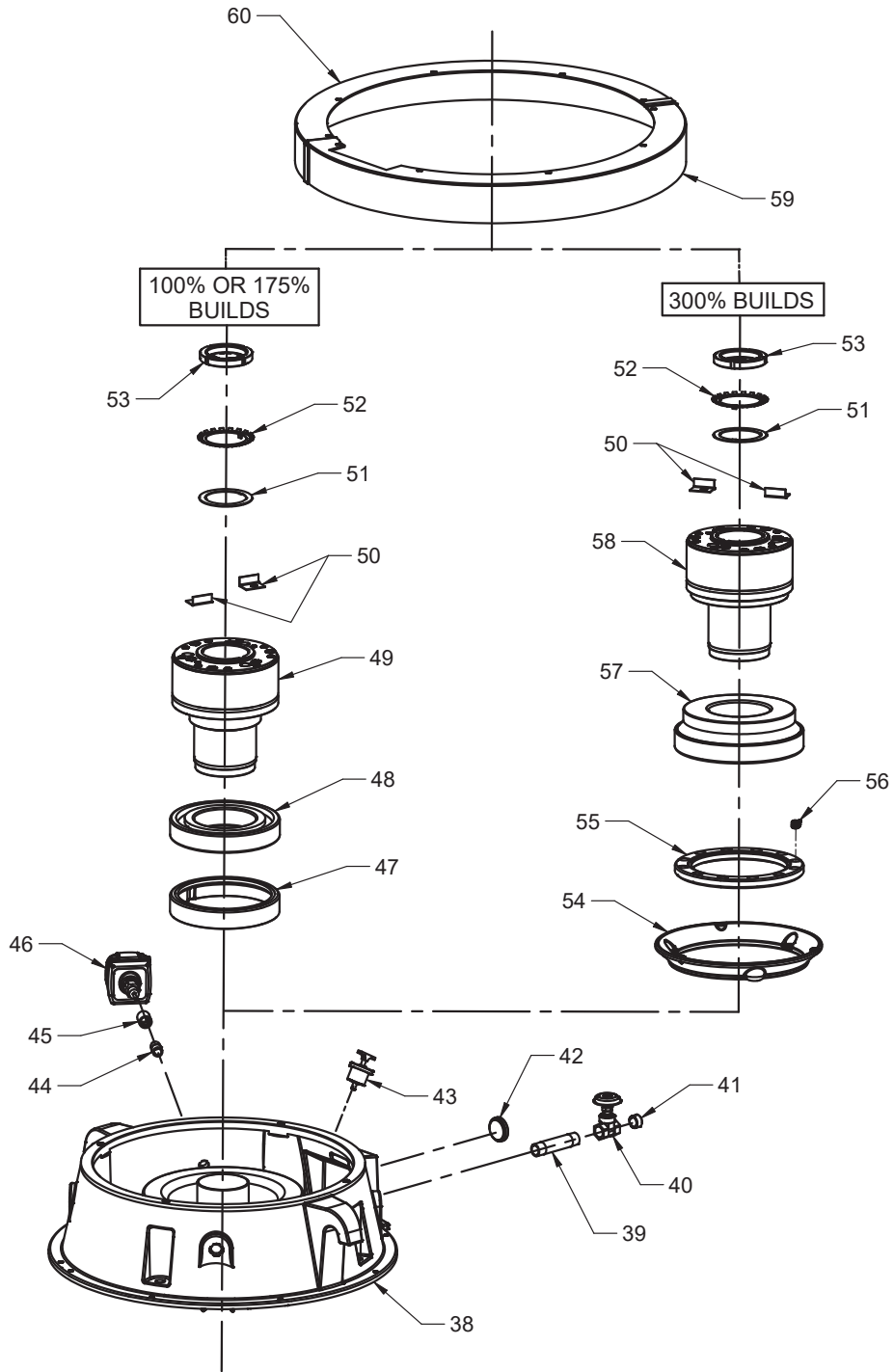

449 Frame (WPI) Type RU and RV4

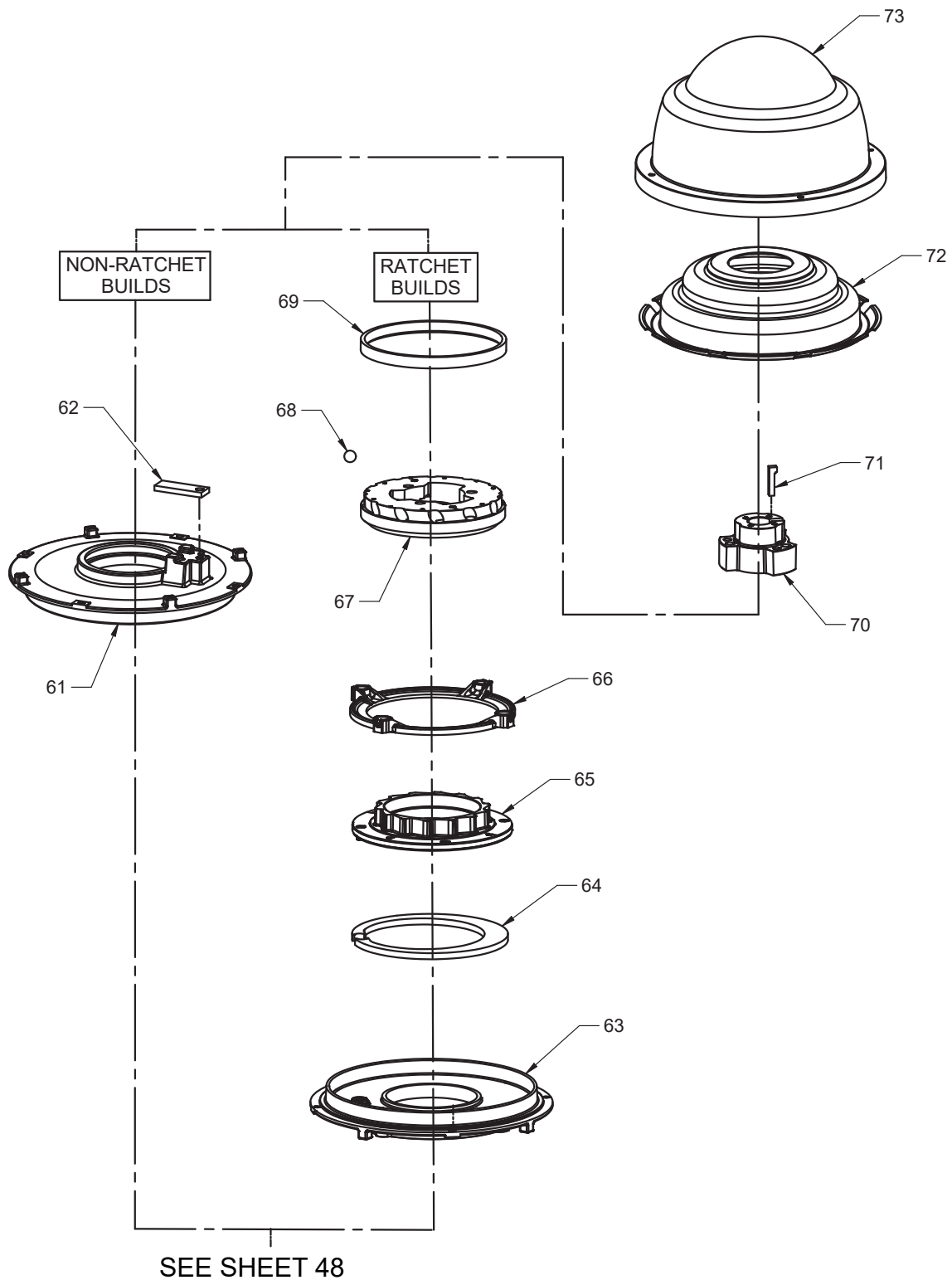

449 Frame (WPI) Type RU and RV4

ITEM NO.	QTY	NAME OF PART
1	1	Lower Bracket
2	1	Shaft Water Slinger
3	1	Pipe Nipple (Lower Oil Drain)
4	1	Pipe Coupling (Lower Oil Drain)
5	1	Pipe Plug (Lower Oil Drain)
6	1	Pipe Nipple (Lower Oil Fill)
7	1	Pipe Coupling (Lower Oil Fill)
8	1	Pipe Plug (Lower Oil Fill)
9	As Req'd	Pipe Coupling (Lower Bearing Temp. Detector)
10	As Req'd	Pipe Coupling (Lower Bearing Temp. Detector)
11	As Req'd	Condulet Head (Lower Bearing Temp. Detector)
12	1	Lower Lock Nut
13	1	Lower Lock Washer
14	As Req'd	Lower Insulation Washer
15	1	Lower Bearing
16	1	Lower Bearing Cap
17	1	Rotor Assembly
18	1	Rotor Core
19	1	Rotor Shaft
20	1	Square Key (Bearing Mounting to Shaft)
21	1	Screen Lower Exhaust
22	1	Screen Lower Intake
23	1	Lower Air Deflector
24	1	Stator Assembly
25	4	Exhaust Screens
26	3	Gasket (Outlet Box Base to Stator)
27	3	Cover (Outlet Box To Stator)
28	1	Gasket (Outlet Box Base to Stator)
29	1	Outlet Box Base
30	1	Gasket (Outlet Box Base to Cover)
31	As Req'd	Outlet Box Cover
32	As Req'd	Gasket (Separate Outlet Box to Frame)
33	As Req'd	Base (Outlet Box)
34	As Req'd	Gasket (Separate Outlet Box Base to Cover)
35	As Req'd	Cover (Separate Outlet Box Cover)
36	1	Upper Air Deflector
37	1	Upper Screen Exhaust

ITEM NO.	QTY	NAME OF PART
38	1	Upper Bracket
39	1	Pipe Nipple (Upper Oil Drain)
40	1	Gate Valve (Upper Oil Drain)
41	1	Pipe Plug (Upper Oil Drain)
42	1	Oil Sight Gauge Window
43	1	Oil Fill Plug (Expanding)
44	As Req'd	Pipe Coupling (Upper Bearing Temp. Detector)
45	As Req'd	Pipe Coupling (Upper Bearing Temp. Detector)
46	As Req'd	Condulet Head (Upper Bearing Temp. Detector)
47	1	Bearing Spacer (or Tandem Thrust Bearing)
48	1	Upper Thrust Bearing
49	1	Bearing Mounting
50	2	Mounting Brackets (RV4 Only)
51	1	Washer (Bearing Mount)
52	1	Lockwasher (Brg Mtg to Shaft)
53	1	Locknut (Brg Mtg to Shaft)
54	1	Oil Baffle (EHT Bearing)
55	1	Bearing Spacer (EHT Bearing)
56	As Req'd	Die Spring (EHT Bearing)
57	1	Bearing (EHT Bearing)(When Supplied)
58	1	Bearing Mount (EHT Bearing)
59	1	Cover (Non-Oil Arm)
60	1	Cover (Oil Arm)
61	1	Dust Cover (Only on Units Without Ratchet)
62	1	Locking Arm (RU Only)
63	1	Ratchet Adaptor (Only on Units With Ratchet)
64	1	Connection Spring (Only on Units With Ratchet)
65	1	Stationary Ratchet (Only on Units With Ratchet)
66	1	Pressure Plate (Only on Units With Ratchet)
67	1	Rotating Ratchet (Only on Units With Ratchet)
68	As Req'd	Ratchet Ball (Only on Units With Ratchet)
69	1	Ball Retaining Ring (Only on Units With Ratchet)
70	1	Thrust Coupling (Only on Hollowshaft)
71	1	Gib Key (Only on Hollowshaft)
72	1	Baffle Upper
73	1	Canopy Cap

449 Frame (WP11) Type RU and RV4

SEE SHEET 52

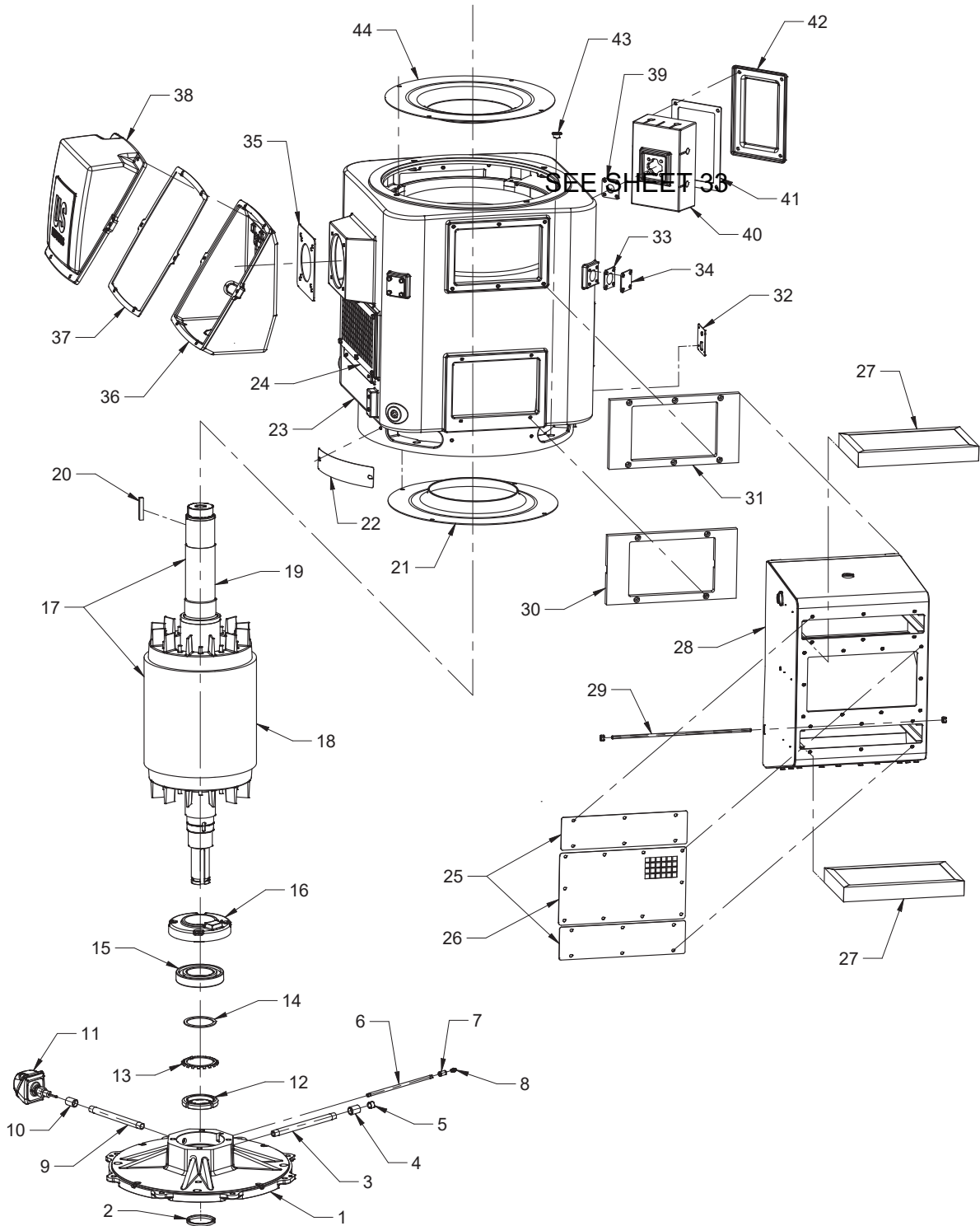

449 Frame (WP11) Type RU and RV4

SEE SHEET 53

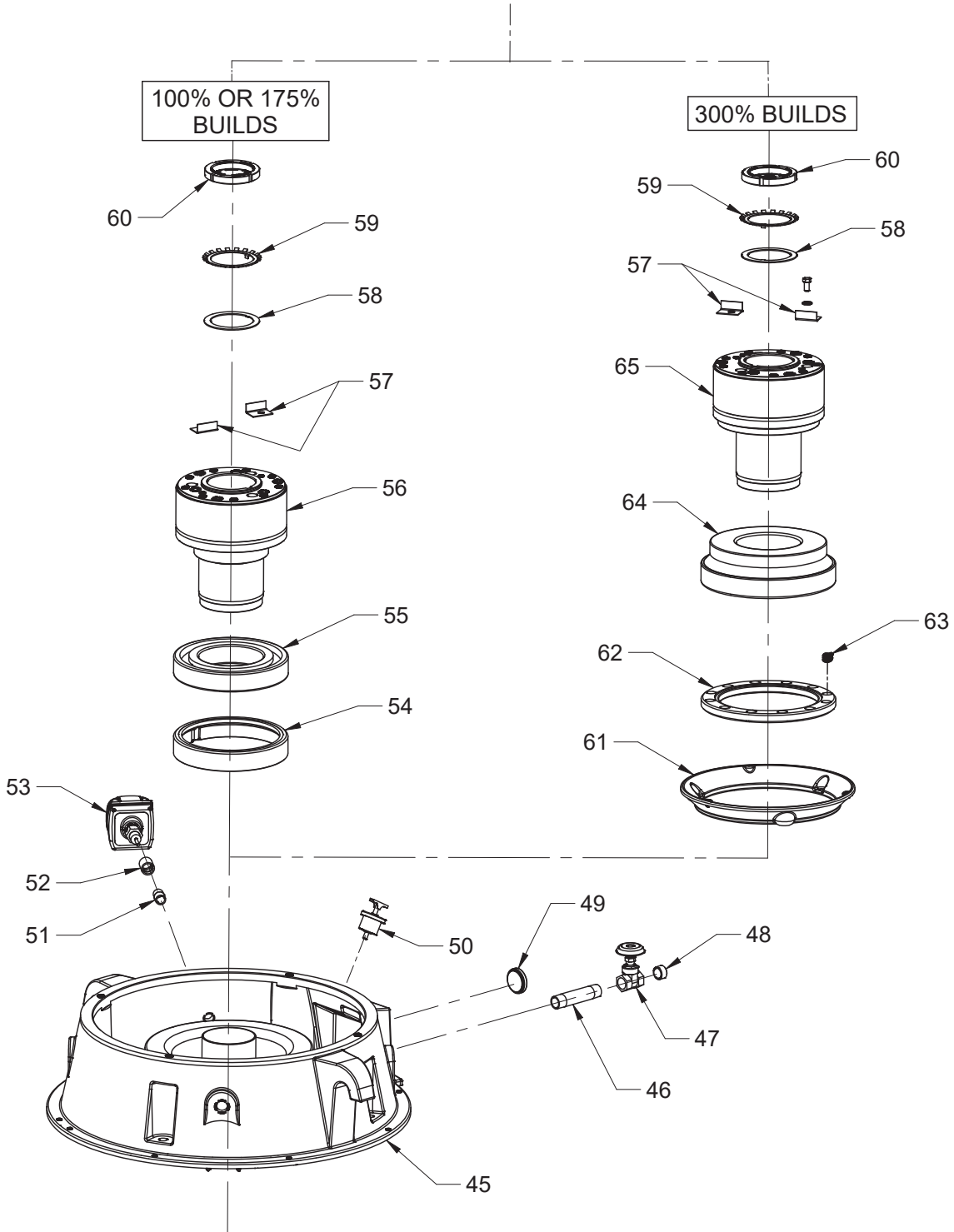

SEE SHEET 52

449 Frame (WP11) Type RU and RV4

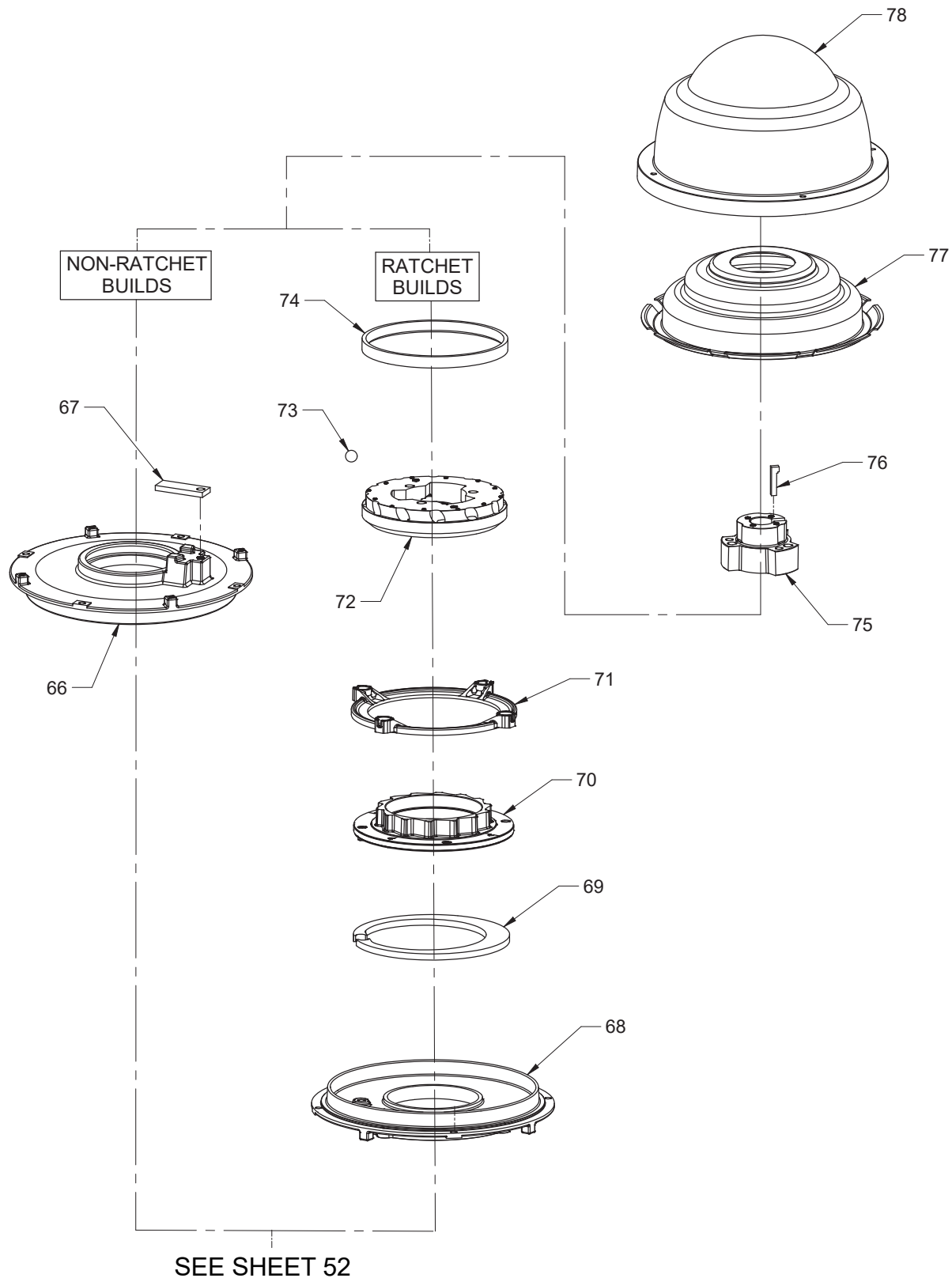

449 Frame (WP11) Type RU and RV4

ITEM NO.	QTY	NAME OF PART	ITEM NO.	QTY	NAME OF PART
1	1	Lower Bracket	40	As Req'd	Base (Outlet Box)
2	1	Shaft Water Slinger	41	As Req'd	Gasket (Separate Outlet Box Base to Cover)
3	1	Pipe Nipple (Lower Oil Drain)	42	As Req'd	Cover (Separate Outlet Box Cover)
4	1	Pipe Coupling (Lower Oil Drain)	43	1	Plug
5	1	Pipe Plug (Lower Oil Drain)	44	1	Upper Air Deflector
6	1	Pipe Nipple (Lower Oil Fill)	45	1	Upper Bracket
7	1	Pipe Coupling (Lower Oil Fill)	46	1	Pipe Nipple (Upper Oil Drain)
8	1	Pipe Plug (Lower Oil Fill)	47	1	Gate Valve (Upper Oil Drain)
9	As Req'd	Pipe Coupling (Lower Bearing Temp. Detector)	48	1	Pipe Plug (Upper Oil Drain)
10	As Req'd	Pipe Coupling (Lower Bearing Temp. Detector)	49	1	Oil Sight Gauge Window
11	As Req'd	Condulet Head (Lower Bearing Temp. Detector)	50	1	Oil Fill Plug (Expanding)
12	1	Lower Lock Nut	51	As Req'd	Pipe Coupling (Upper Bearing Temp. Detector)
13	1	Lower Lock Washer	52	As Req'd	Pipe Coupling (Upper Bearing Temp. Detector)
14	As Req'd	Lower Insulation Washer	53	As Req'd	Condulet Head (Upper Bearing Temp. Detector)
15	1	Lower Bearing	54	1	Bearing Spacer (or Tandem Thrust Bearing)
16	1	Lower Bearing Cap	55	1	Upper Thrust Bearing
17	1	Rotor Assembly	56	1	Bearing Mounting
18	1	Rotor Core	57	2	Mounting Brackets (RV4 Only)
19	1	Rotor Shaft	58	1	Washer (Bearing Mount)
20	1	Square Key (Bearing Mounting to Shaft)	59	1	Lockwasher (Brg Mtg to Shaft)
21	1	Screen Lower Exhaust	60	1	Locknut (Brg Mtg to Shaft)
22	1	Screen Lower Intake	61	1	Oil Baffle (EHT Bearing)
23	1	Lower Air Deflector	62	1	Bearing Spacer (EHT Bearing)
24	1	Stator Assembly	63	As Req'd	Die Spring (EHT Bearing)
25	4	Filter Cover	64	1	Bearing (EHT Bearing)(When Supplied)
26	2	Intake Screen	65	1	Bearing Mount (EHT Bearing)
27	2	Filter	66	1	Dust Cover (Only on Units Without Ratchet)
28	2	WP11 Cover	67	1	Locking Arm (RU Only)
29	2	Threaded Rod (Cover Mounting)	68	1	Ratchet Adaptor (Only on Units With Ratchet)
30	2	Lower Plate	69	1	Connection Spring (Only on Units With Ratchet)
31	2	Upper Plate	70	1	Stationary Ratchet (Only on Units With Ratchet)
32	1	Cover Plate	71	1	Pressure Plate (Only on Units With Ratchet)
33	3	Gasket (Outlet Box Base to Stator)	72	1	Rotating Ratchet (Only on Units With Ratchet)
34	3	Cover (Outlet Box To Stator)	73	As Req'd	Ratchet Ball (Only on Units With Ratchet)
35	1	Gasket (Outlet Box Base to Stator)	74	1	Ball Retaining Ring (Only on Units With Ratchet)
36	1	Outlet Box Base	75	1	Thrust Coupling (Only on Hollowshaft)
37	1	Gasket (Outlet Box Base to Cover)	76	1	Gib Key (Only on Hollowshaft)
38	As Req'd	Outlet Box Cover	77	1	Baffle Upper
39	As Req'd	Gasket (Separate Outlet Box to Frame)	78	1	Canopy Cap

5000 - 6800 Frame, Type HU & HV4
 8000 Frame, Type RU & RV (4 Pole and Slower)

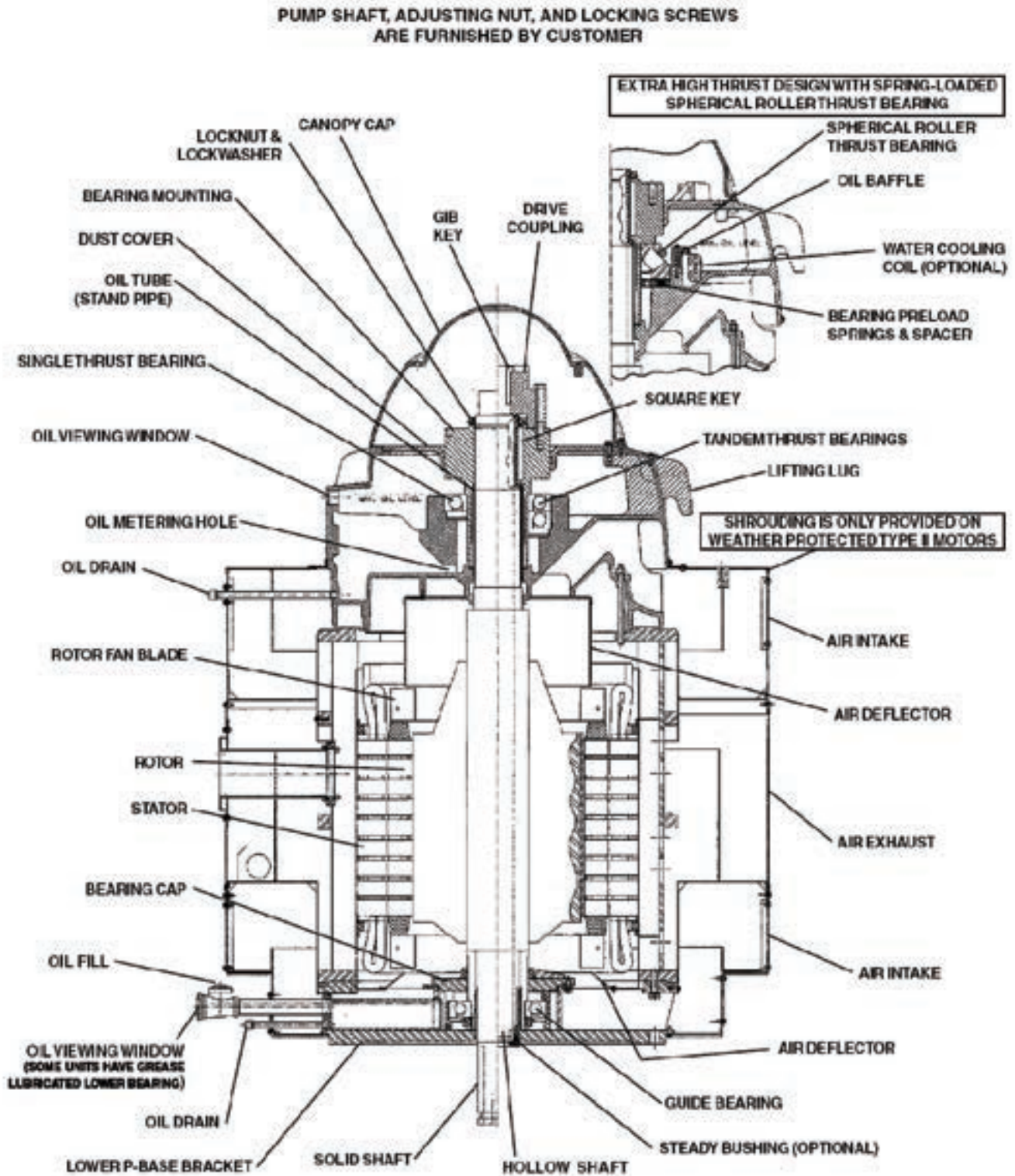

5000 and 5800 Frame WP11 Type RU and RV-4

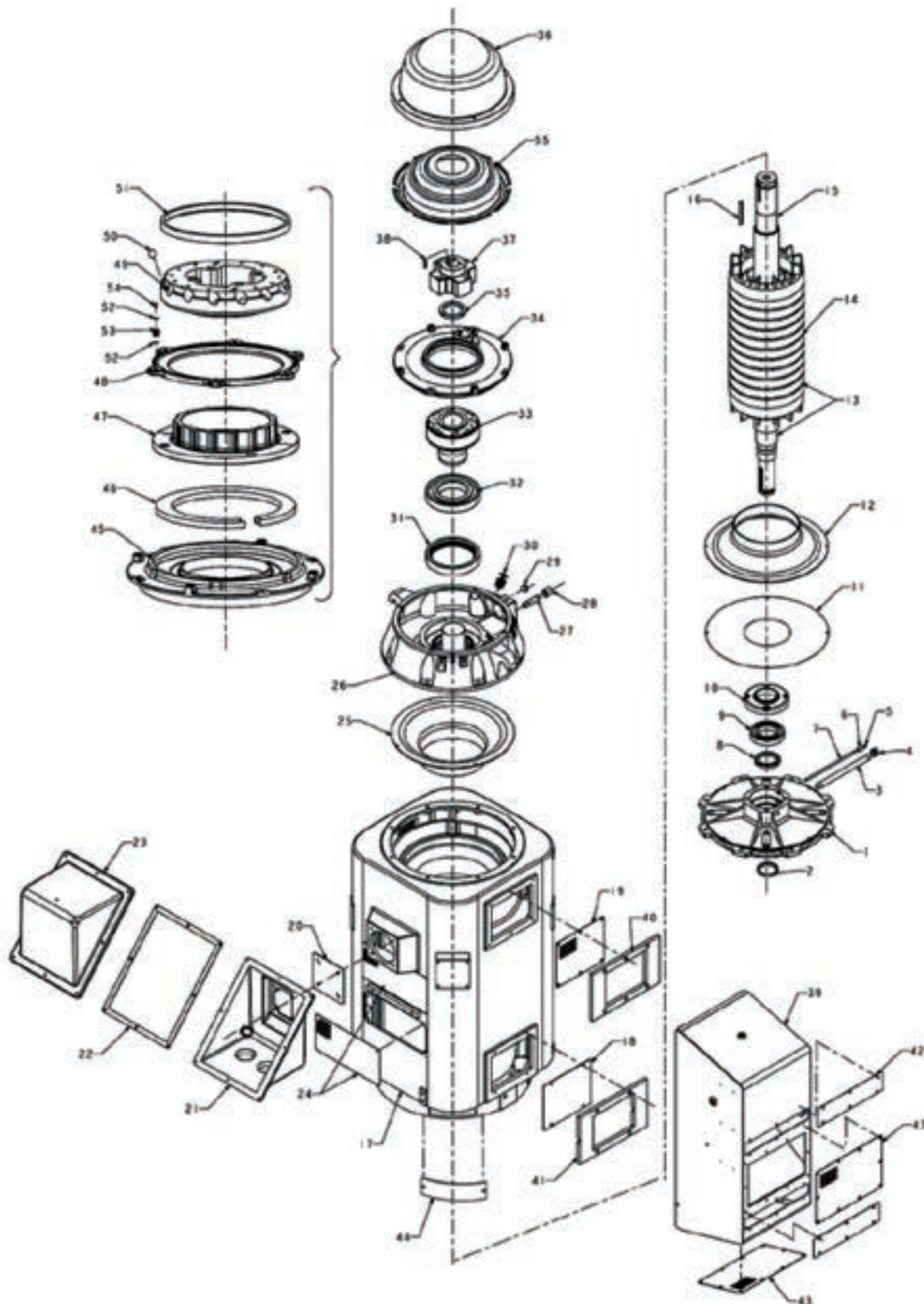

5000 and 5800 Frame Type RU and RV-4

ITEM NO.	QTY	NAME OF PART	ITEM NO.	QTY	NAME OF PART
1	1	Lower Bracket	32	1	Upper Thrust Bearing
2	1	Shaft Water Slinger	33	1	Bearing Mounting
3	1	Pipe Nipple (Lower Grease Drain)	34	1	Dust Cover (Only on Units Without Ratchet)
4	1	Pipe Cap (Lower Grease Drain)	35	1	Locknut and Lockwasher (Brg Mtg to Shaft)
5	1	Grease Zerk Fitting	36	1	Canopy Cap
6	1	Pipe Coupling (Lower Grease Fill)	37	1	Thrust Coupling (Only on Hollowshaft)
7	1	Pipe Nipple (Lower Grease Fill)	38	1	Gib Key (Only on Hollowshaft)
8	1	Locknut and Lockwasher (Lower Bearing)	39	2	WP2 Intake Box (Only on WP-2)
9	1	Lower Bearing	40	2	Upper Adapter Flange (Only on WP-2)
10	1	Lower Bearing Cap	41	2	Lower Adapter Flange (Only on WP-2)
11	1	Lower Intake Screen (Only on WP-1)	42	4	Filter Access Cover (Only on WP-2)
12	1	Lower Air Deflector	43	4	Intake Screen (Only on WP-2)
13	1	Rotor Assembly	44	4	Cover (Flange Access) (Only on WP-2)
14	1	Rotor Core	45	1	Ratchet Adaptor (Only on Units With Ratchet)
15	1	Rotor Shaft	46	1	Connection Spring (Only on Units With Ratchet)
16	1	Square Key (Bearing Mounting to Shaft)	47	1	Stationary Ratchet (Only on Units With Ratchet)
17	1	Stator Assembly	48	1	Pressure Plate (Only on Units With Ratchet)
18	1	Lower Air Intake Cover (Only on WP-1)	49	1	Rotating Ratchet (Only on Units With Ratchet)
19	1	Upper Air Intake Screen (Only on WP-1)	50	12-(5008) 14-(5012) 16-(5813)	Ratchet Ball (Only on Units With Ratchet)
20	1	Gasket (Outlet Box Base to Stator)	51	1	Ball Retaining Ring (Only on Units With Ratchet)
21	1	Outlet Box Base	52	4-(5008) 12-(5012) 8-(5813)	Plain Washer (Only on Units With Ratchet)
22	1	Gasket (Outlet Box Cover to Base)	53	4-(5008) 6-(5012) 8-(5813)	Die Spring (Only on Units With Ratchet)
23	1	Outlet Box Cover	54	4-(5008) 6-(5012) 8-(5813)	Screw (Only on Units With Ratchet)
24	2-(5008) 4-(5012) 4-(5813)	Exhaust Screen	55	1	Pressurization Baffle (5000 Frame Only)
25	1	Upper Air Deflector			
26	1	Upper Bracket			
27	1	Pipe Nipple (Oil Drain)			
28	1	Pipe Cap (Oil Drain)			
29	1	Oil Sight Gauge Window			
30	1	Oil Fill Plug (Expanding)			
31	1	Bearing Spacer (or Tandem Thrust Bearing)			

5000 Frame ODP/WPI Type RU & RV4 - High Thrust

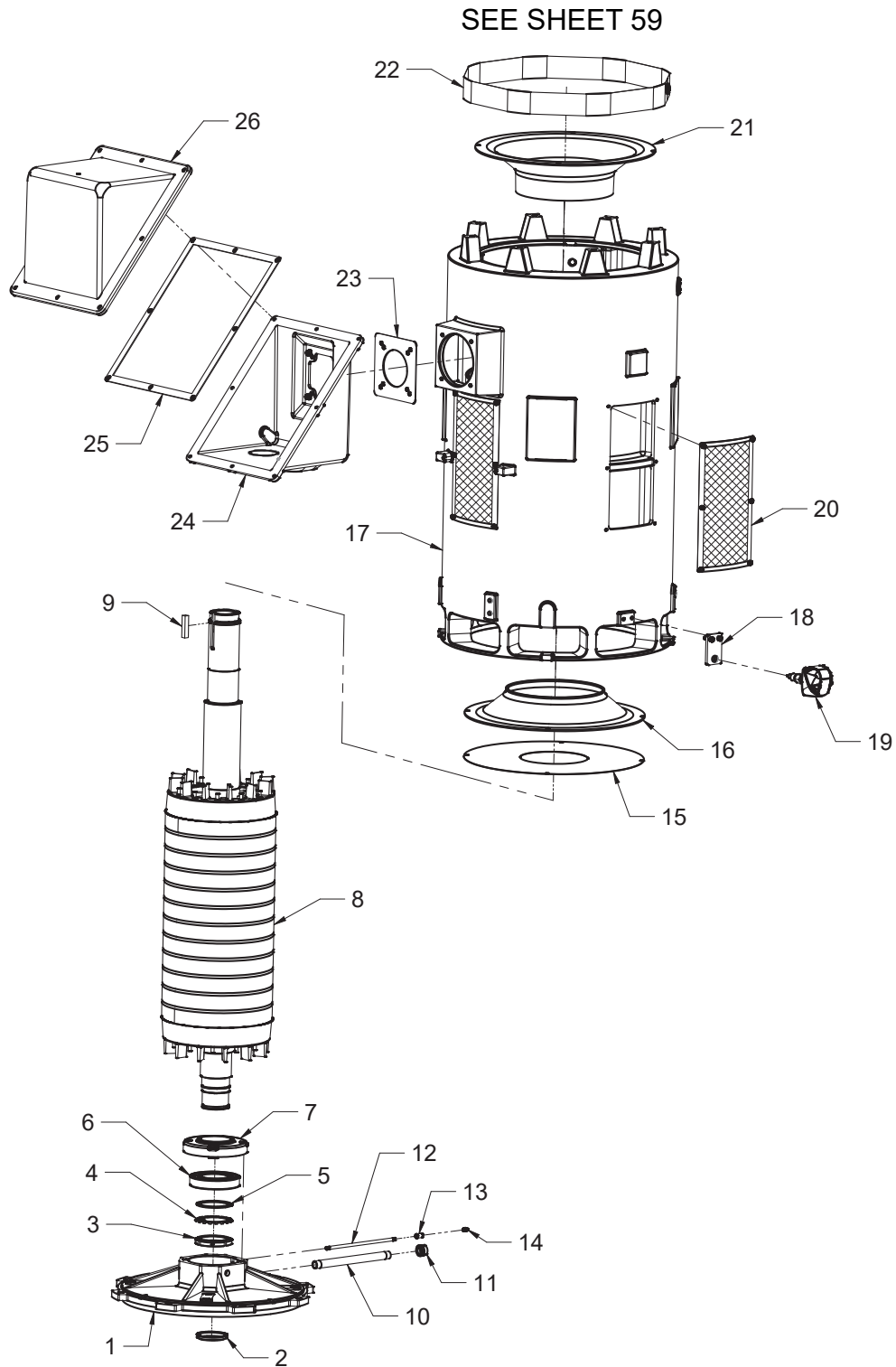

5000 Frame ODP/WPI
Type RU, RV4 - High Thrust

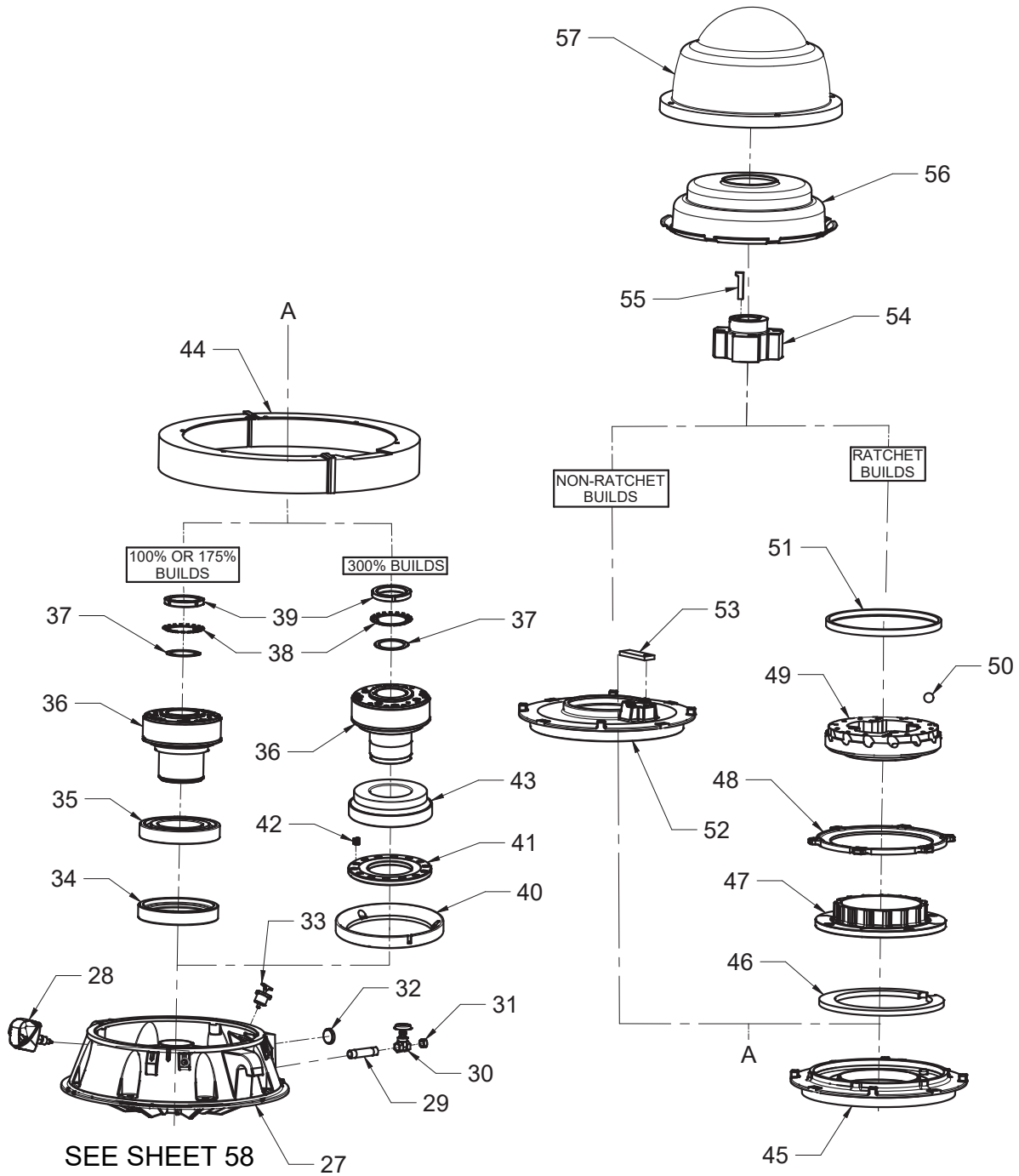

5000 Frame ODP/WPI Type RU and RV4 - High Thrust

ITEM NO.	QTY	NAME OF PART	ITEM NO.	QTY	NAME OF PART
1	1	Lower Bracket	28	1	BTD Housing Upper
2	1	Water Deflector	29	1	Oil Tube Drain Upper
3	1	Lock Nut Lower	30	1	Oil Gate Valve Upper
4	1	Lock Washer Lower	31	1	Plug Upper Gate Valve
5	1	Spacer Wshr Insul. {Only for Insul Lower Brg}	32	1	Sight Gauge Window
6	1	Bearing Lower	33	1	Oil Fill Plug
7	1	Bearing Cap	34	1	Spacer Bearing
8	1	Rotor assembly	35	1	Bearing Upper
9	1	Upper Bearing Mount Key	36	1	Bearing Mount
10	1	Coupling Lower Grease Drain	37	1	Spacer Wshr Insul. (Only for Insul Upper Brg)
11	1	Nipple Lower Grease Drain	38	1	Lockwasher Upper
12	1	Coupling Lower Grease Fill	39	1	Lock Nut Upper
13	1	Nipple Lower Grease Fill	40	1	Ring Upper Spherical Brg
14	1	Lower Grease Fill Fitting	41	1	Pressure Plate Spherical Brg
15	1	Screen Lower	42	12	Spring
16	1	Air Deflector Lower	43	1	Bearing Spherical
17	1	Stator assembly	44	1	Cover Upper
18	1	BTD mounting Plate	45	1	Cover Non-Reversing Ratchet
19	1	BTD Housing Lower	46	1	Pressure Plate Non-reversing Ratchet
20	4	Screen Exhaust	47	1	Stationary Ratchet
21	1	Upper Air Deflector	48	1	Locking Ring Non-Reversing Ratchet
22	1	Screen Upper Intake	49	1	Rotating Ratchet Non-reversing Ratchet
23	1	Gasket Outlet box	50	12	Ball Non-Reversing Ratchet
24	1	Cover Outlet Box	51	1	Ring Securing Balls
25	1	Gasket Outlet Box	52	1	Dust Ring
26	1	Cover Outlet Box	53	1	Locking Arm
27	1	Lower Bracket Assembly	54	1	Coupling
28	2	WPII Cover	55	1	Gib Key
29	2	Threaded Rod (Cover Mounting)	56	1	Baffle
			57	1	Canopy Cap

**6813 Frame
Type RU, RV-4**

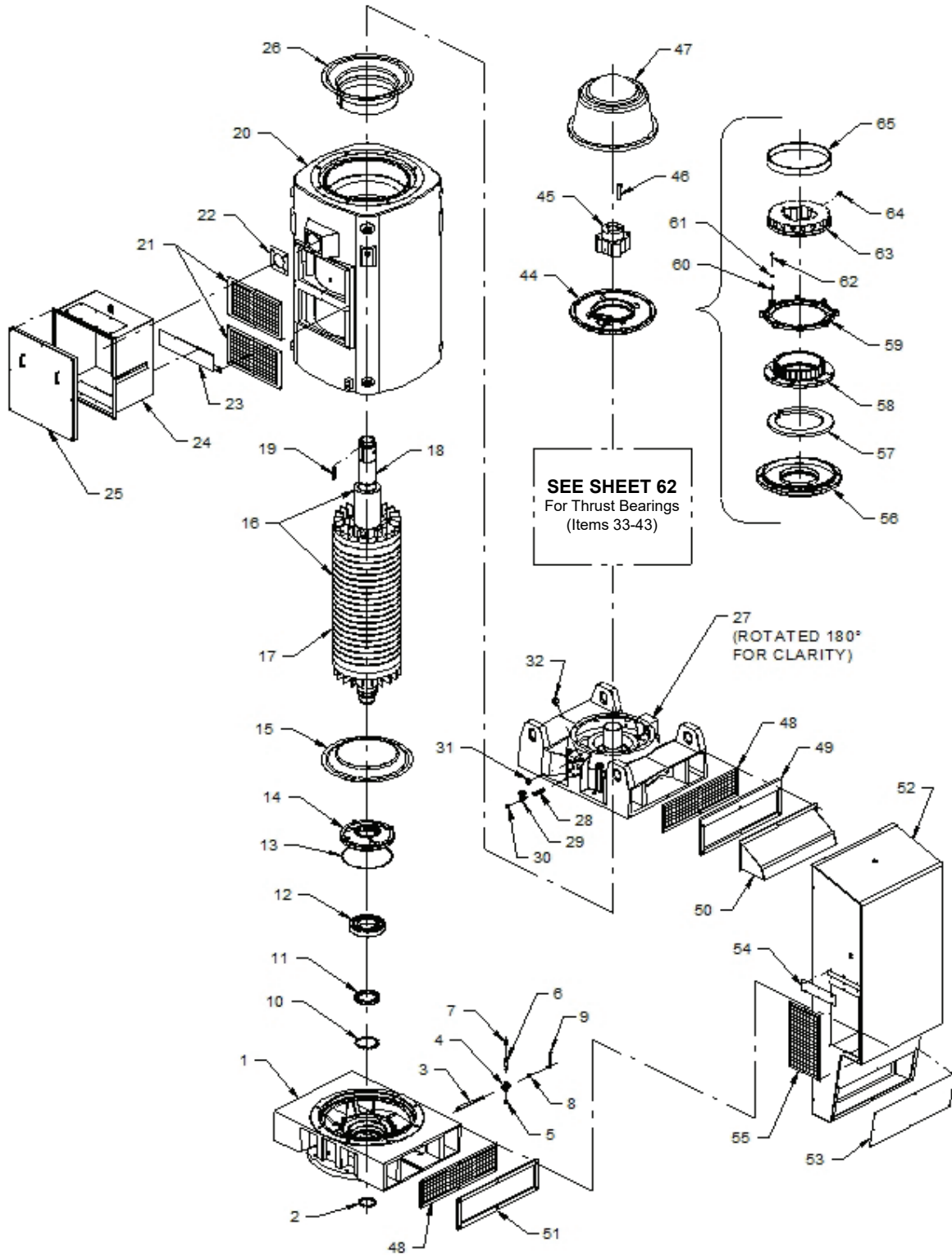

6813 Frame Type RU, RV-4

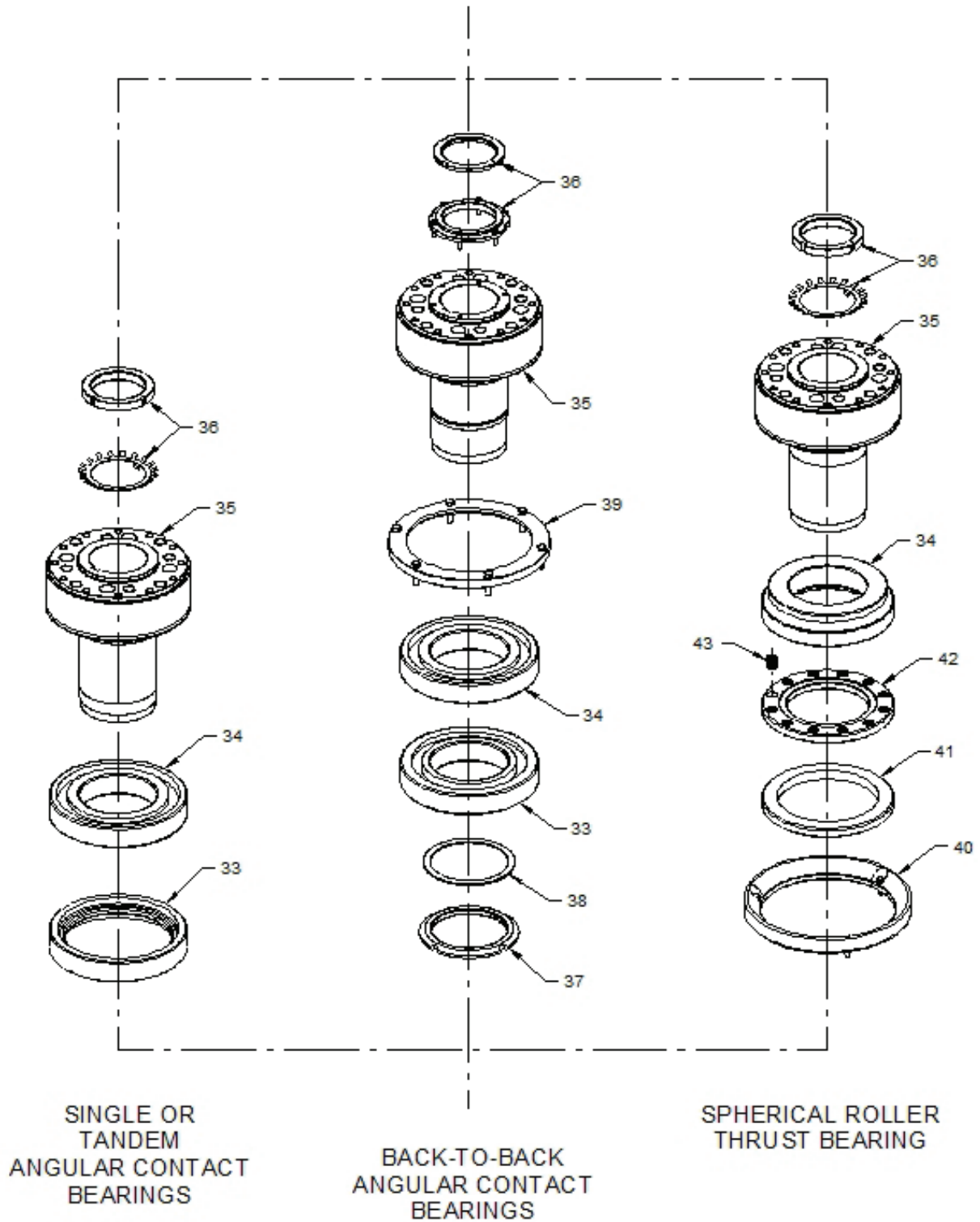
THRUST BEARING DETAILS

6813 Frame Type RU and RV-4

ITEM NO.	QTY	NAME OF PART	ITEM NO.	QTY	NAME OF PART
1	1	Lower Bracket	34	1	Upper Thrust Bearing
2	1	Shaft Water Slinger	35	1	Bearing Mounting
3	1	Pipe Nipple (Lower Oil Drain)	36	1	Locknut and Lockwasher (Brg Mtg to Shaft)
4	1	Pipe Tee (Lower Oil Drain)	37	1	Locknut and Set Screws (Back-to-Back Brgs.)
5	1	Pipe Plug (Lower Oil Drain)	38	1	Bearing Spacer (Insul.)(Back-to-Back Brgs.)
6	1	Pipe Nipple (Lower Oil Fill)	39	1	Bearing Cap (Clamping)(Back-to-Back Brgs.)
7	1	Pipe Cap (Lower Oil Fill)	40	1	Oil Baffle (EHT Bearing)
8	1	Reducer Bushing	41	1	Bearing Support (EHT Bearing)(When Supplied)
9	1	Oil Sight Gauge Window	42	1	Bearing Spacer (EHT Bearing)
10	1	Lockwasher (Lower Bearing)	43	As Req'd	Die Spring (EHT Bearing)
11	1	Locknut (Lower Bearing)	44	1	Dust Cover (Only on Units Without Ratchet)
12	1	Lower Bearing	45	1	Thrust Coupling (Only on Hollowshaft)
13	1	O-Ring	46	1	Gib Key (Only on Hollowshaft)
14	1	Lower Bearing Cap	47	1	Fan Cover
15	1	Lower Air Deflector	48	4	Bracket Screen (Upper and Lower)
16	1	Rotor Assembly	49	2	Upper Flange Adaptor (Only On WP-2)
17	1	Rotor Core	50	2	Upper Air Scoop (Only On WP-1)
18	1	Rotor Shaft	51	2	Lower Flange Adaptor (Only On WP-2)
19	1	Square Key (Bearing Mounting to Shaft)	52	2	WP-2 Intake Box (Only On WP-2)
20	1	Stator Assembly	53	2	Access Cover (Only On WP-2)
21	4	Exhaust Screens	54	4	Filter Access Cover (Only On WP-2)
22	1	Gasket (Outlet Box Base to Stator)	55	4	Intake Screen (Only On WP-2)
23	1	Mounting Bracket (Outlet Box To Stator)	56	1	Ratchet Adaptor (Only on Units With Ratchet)
24	1	Outlet Box Base	57	1	Connection Spring (Only on Units With Ratchet)
25	1	Outlet Box Cover	58	1	Stationary Ratchet (Only on Units With Ratchet)
26	1	Upper Air Deflector	59	1	Pressure Plate (Only on Units With Ratchet)
27	1	Upper Bracket	60	6	Die Spring (Only on Units With Ratchet)
28	1	Pipe Nipple (Upper Oil Drain)	61	6	Plain Washer (Only on Units With Ratchet)
29	1	Gate Valve (Upper Oil Drain)	62	6	Screw (Only on Units With Ratchet)
30	1	Pipe Plug (Upper Oil Drain)	63	1	Rotating Ratchet (Only on Units With Ratchet)
31	1	Oil Sight Gauge Window	64	As Req'd	Ratchet Ball (Only on Units With Ratchet)
32	1	Oil Fill Plug (Expanding)	65	1	Ball Retaining Ring (Only on Units With Ratchet)
33	1	Bearing Spacer (or Tandem Thrust Bearing)			

9600 Frame
Types RU and RV-4

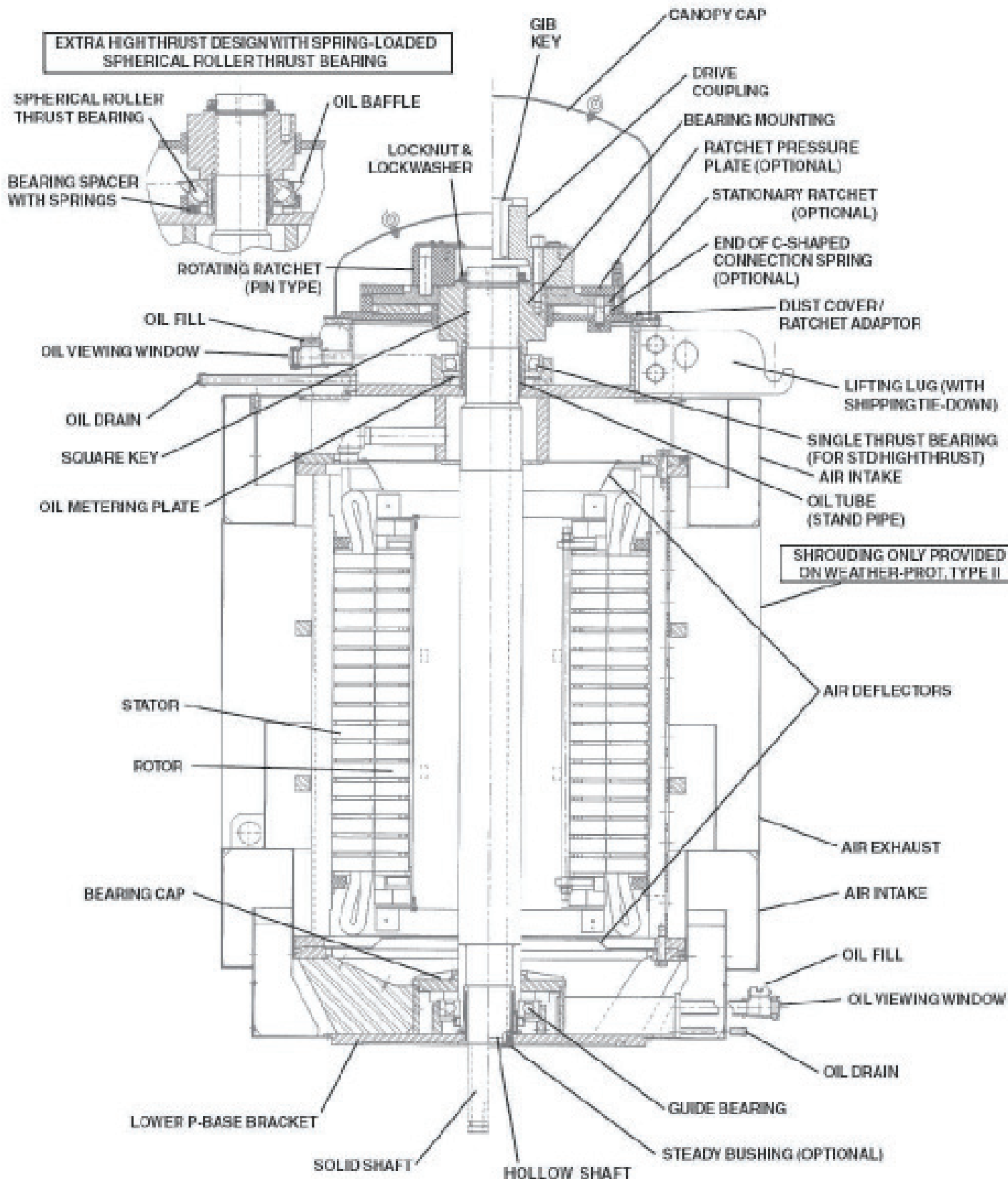

Installation Record

Nameplate and Installation Information

SERIAL NUMBER OR MODEL NUMBER.....
 HORSEPOWER.....
 MOTOR RPM.....
 PHASE.....
 FREQUENCY.....
 AMPS..... AT
 DESIGN.....
 FRAME.....
 DATE PURCHASED..... P.C. NUMBER
 DATE INSTALLED.....
 LOCATION OF JOB SITE.....
 MACHINE OR INSTALLATION NUMBER.....
 PURCHASED FROM.....
 MOTOR RESISTANCE LINE TO LINE AT TIME OF INSTALLATION...

VOLTS

INSULATION TO GROUND READING AT TIME OF INSTALLATION...

RECORD OF MAINTENANCE

GRADE AND TYPE OF LUBRICANT USED.....

DATE OF LAST RELUBRICATION	INSULATION RESISTANCE		OVERHAUL OR REPAIR	
	DATE	MEGOHMS	DATE	ACTION

Table 6: Threaded Fastener Torque Requirements

All threaded fasteners used for rigid joints (cast iron and low carbon steel) in products of Nidec Motor Corporation, are to be tightened to the torque values listed in the following tabulation. Values are based upon dry assembly.

Diameter of Fastener	Number of Threads Per Inch	Grade 5 Fasteners	Grade 2 Fasteners
#6	32	16 lb-in	10 lb-in
	40	18	12
#8	32	30	19
	36	31	20
#10	24	43	27
	32	49	31
#12	24	66	37
	28	72	40
1/4"	20	96	66
	28	120	76
5/16"	18	16 lb-ft	11 lb-ft
	24	18	12
3/8"	16	29	20
	24	34	23
7/16"	14	46	30
	20	52	35
1/2"	13	70	50
	20	71	55
9/16"	12	102	
	18	117	
5/8"	11	140	
	18	165	
3/4"	10	249	
	16	284	
7/8"	9	401	
	14	446	
1"	8	601	
	14	666	
1-1/8"	7	742	
	12	860	
1-1/4"	7	1046	
	12	1196	
1-3/8"	6	1371	
	12	1611	
1-1/2"	6	1820	
	12	2110	

Table 7: TEFC, WPI, WPII Motor Weights (lbs.)

	Motor Weight with Pallet*	TEFC	WPI	WPII
Frame Size	182	200	150	
	184	200	150	
	213	300	300	
	215	300	300	
	254	450	400	
	256	450	400	
	284	650	450	
	286	650	450	
	324	800	800	
	326	800	800	
	364	1050	900	
	365	1050	900	
	404	1600	1200	
	405	1600	1200	
	444	2000	1700	
	445	1650	1800	
	447	2400	2300	
	449	4000	3600	4300
	5006		3400	3300
	5007		3400	3700
5008	4100	4500	4800	
5009		3700	4000	
5012		5900	6400	

	Motor Weight with Pallet*	TEFC	WPI	WPII
Frame Size	5807	6000		
	5808		4500	4500
	5809	7100	4800	5000
	5810		5100	5500
	5811	8000		
	5812	10400		
	5813		10300	11100
	6808		8000	8900
	6810		9600	10600
	6812	16800		
	6813		19300	20400
	8004		11000	
	8006		11700	12500
	8007		12200	13000
	8008		12800	13600
	8009		13900	14700
	8010		14800	15700
	8011		15800	16700
	8012		16400	17200
	9603		15900	16700
	9604		17000	17800
	9605		18100	18900
	9606		19200	20000

* Refer to Nameplate for Actual Motor Weight and Section II for Handling/Lifting

Appendices

Effects of Unbalanced Line Voltage

A potential cause of premature motor failure is unbalanced line (supply) voltage. Three phase motors produce useful work when they efficiently convert electrical energy into mechanical energy. This is accomplished when each phase of the supply voltage is of equal strength and works in harmony to produce a rotating magnetic field within the motor.

When the value of supply voltage leg to leg is not equal (e.g. 460-460-460), the risk of unbalanced line voltage is present. If this voltage unbalance exceeds about 1%, excessive temperature rise will result. Unless the motor HP capacity is derated to compensate, the motor will run hot resulting in degradation of the insulation system and bearing lubricant.

From NEMA^{®†} MG-1, 14.36: Derating factors due to unbalanced line voltage

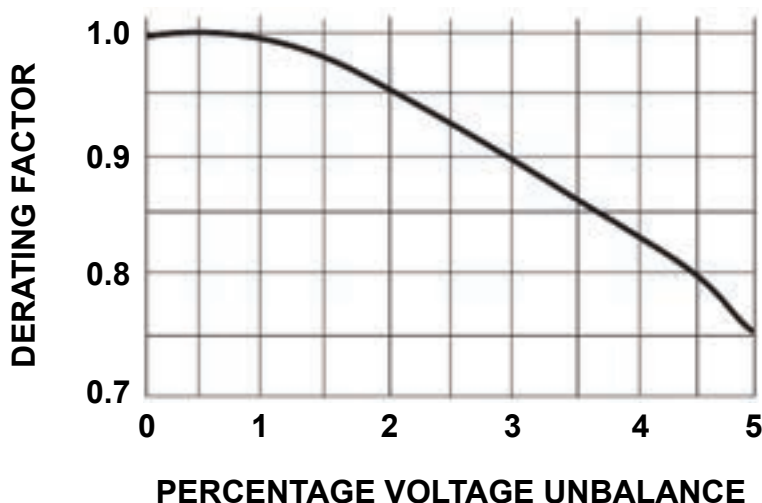

EXAMPLE: Field ratings of Phase A - 480 v, Phase B = 460 v, Phase C = 450 v

As a rule of thumb, the percentage increase in temperature rise will be about two times the square of the percentage voltage unbalance. In this case, the average voltage $(480+460+450)$ is equal to 463 volts. The maximum deviation between legs is 17 volts $(480-463)$ volts).

The Percentage voltage unbalance is determined as follows: $17 / 463 \times 100 = 3.7\%$. The temperature rise will then increase $(3.7)^2 \times 2 = 27\%$. This condition will reduce the typical life of your motor to less than 25% of its design life. Should this condition be present, call your electric utility and resolve your unbalanced supply condition.

Other areas of motor performance will also be affected - e.g., loss of torque capacity, change in full load RPM, greatly unbalanced current draw at normal operating speed. Refer to NEMA^{®†} MG-1 section 14.36 for details.

Motors Applied to Variable Frequency Drives (VFD's)

Electrical motors can be detrimentally affected when applied with variable frequency drives (VFD's). The non-sinusoidal waveforms of VFD's have harmonic content which causes additional motor heating; and high voltage peaks and short rise times, which result in increased insulation stress, especially when long power cable lengths are used. Standard motors utilized with VFD's must be limited to those application considerations defined in **NEMA MG-1 Part 30**.

NEMA MG-1 Part 31 defines performance and application considerations for Definite-Purpose Inverter Fed motors. To insure satisfactory performance and reliability, Nidec Motor Corporation offers and recommends nameplated inverter duty motor products which meet the requirements of NEMA MG-1 Part 1. The use of non-inverter duty motors may result in unsatisfactory performance or premature failure, which may not be warrantable under the Terms and Conditions of Sale. Contact your Nidec Motor Corporation Field Sales Engineer for technical assistance in motor selection, application and warranty details.

Electric Motor Load Test Using the Watt Hour Meter

In the analysis of electric motors, it is desirable to conduct an accurate load check on a particular installation to determine whether the motor is operating within the rating and horsepower for which it was designed. Since most pumps installations have their own watt hour meters, accurate readings will permit a load check via the following formula:

K = Disc constant (watts per revolution of disc per hour). This is typically found on the meter face.

R = Revolutions of disc in watt meter within the time of the test.

T = Time of test, in seconds.

Transformer Ratio = Stated on meter face. Must be included where current transformers are used with watt meters.

To obtain input kilowatts:

$$\text{Input KW} = \frac{K \times R \times 3.6}{T}$$

To obtain input horsepower:

$$\text{Input HP} = \frac{K \times R \times 4.83 \times \text{Transformer Ratio}}{T}$$

The watt hour meter measures power consumed over a period of time. It is necessary to establish the rate at which power is being consumed by the work being done. We establish this rate by counting the revolutions of the disc in a given time. Here is the typical example of a load check:

GIVEN

- Pump motor to be load checked is rated 100 HP, 1800 HP, 3-Phase, 60 Hz, 1.15 service factor, 91.0 Percent Efficiency
- Disc constant (K) found on face of meter = 40
- Transformer ratio found on face of meter = 3

DATA FOUND FROM TESTS

With stop watch, disc was observed to revolve 10 times in exactly 49 seconds. Therefore, R=10; T=49.

THUS

$$\text{Input HP} = \frac{40 \times 10 \times 4.83 \times 3}{49}$$

$$\begin{aligned} \text{Output HP} &= \text{Input HP} \times \text{Motor Efficiency} \\ \text{Output HP} &= 118.29 \times 91\% = 107.54 \end{aligned}$$

CONCLUSION

The output HP (107.54) is greater than output HP shown on nameplate (100 HP) but is well within the 1.15 service factor which applies to this motor.

Installation / Maintenance Notes

Member of the following:



† All marks shown within this document are properties of their respective owners.

Nidec Motor Corporation, 2021; All Rights Reserved.
U.S. MOTORS® is a registered trademark of Nidec Motor Corporation.
Nidec Motor Corporation trademarks followed by the © symbol are registered with the U.S. Patent and Trademark Office.

PN 835172 Rev I, 04/21 IN509-1G
Refer to website for latest version

Nidec
NIDEC MOTOR CORPORATION

8050 W. Florissant Avenue | St. Louis, MO 63136
Phone: 800-566-1418 | Fax: 314-595-8922
www.usmotors.com