



GE INDUSTRIAL MOTORS
a **WOLONG** company

Product Technical Information

November 25, 2020

Data shown is for the current revision model #. Ensure your nameplate model # matches.

Model Number:	5KS256DAE5035A
Catalog Number:	V4004
Instruction Manual:	GEK-95353
Connection Diagram:	GEM2034E-FIG9
Outline Drawing:	4002B5825NSP5210

Accessory Connection Diagrams

Bearing Thermocouple:	None	Heater:	3027JE-1C
RTD:	None	Thermistor:	None
Thermostat:	None	Winding Thermocouple:	None
Bearing RTD:	None		

Table of Contents

Specification	01
Performance Characteristics	02
Outline Drawing	03
Connection Drawing(s)	04
Spare parts	05

Marks:

MODEL NUMBER:	5KS256DAE5035A
Outline Drawing:	4002B5825NSP5210
Connection Diagram:	GEM2034E-FIG9
Instruction Book:	GEK-95353
Design Code:	25BD0072A
Type:	KS
Frame:	L256TP10
Phases:	3
Poles:	2
Output Power:	20HP 14.8KW
RPM:	3550
Voltage:	230/460
Hertz:	60
Amps - FL:	46.0/23.0
Service Factor:	1.15
Alt Service Factor:	--

Estimated Weight:	315 Lbs
Time Rating:	CONT
Enclosure:	WPI
Encl Construction:	OPEN
Ambient Max(°C):	40
Alt Ambient Max(°C):	--
Insulation Class:	H
NEMA Design:	B
Nominal Efficiency:	91.0 %
Guaranteed Efficiency:	89.5 %
3/4 Load Efficiency:	--
KVA Code:	G
Max KVAR:	3.3
Power Factor:	89.5
Bearing - DE:	7309
Bearing - ODE:	6209-2ZC3

Enclosure is Weather Protected One

Stamped Nameplate Notes:

PREMIUM EFFICIENT MOTOR
 NEMA ENCL WPI AND CSA ENCL DP
 ROT CCW FACING ODE LEAD/PH SEQUENCE 1-2-3/1-2-3
 HTR LDS HE1-HE2 115V 60W
 INVERTER DUTY PER NEMA MG1 PART 31
 ALTERNATE RATING FOR PWM CONTROL:
 1.0 SF VAR TORQUE RANGE 2.5-60 HZ
 SUITABLE FOR 15HP, 190/380V,
 50 HZ WITH 41.8/20.9AMPS AND 2955 RPM AT 1.0 SF



Additional Information:

2P - TP EXTN
C/BOX 137 CU IN-1.25 NPT
AUX LEADS EXIT WITH MOTOR LEADS
RCF 5000 CPM, STATIC DEFLECTION .0014 INCHES &
CENTER OF GRAVITY 10.75 INCHES
HOLLOW SHAFT HIGH THRUST
NON REV CPLG W/BX=1.00 KW=0.25
OIL RESISTANT SLEEVING ON LEADS
BEARING LIFE 4365 HOURS AT 2600 LB THRUST
BEARING LIFE 8760 HOURS AT 2048 LB THRUST



Performance Characteristics

1st Winding 1st Connection

Design: 25BD0072A

Marks:

LOAD %	125.0	115.0	100.0	75.0	50.0	25.0	0.0
% EFF	89.2	90.05	91.31	92.34	92.71	90.48	0.00
% PF	87.78	88.59	89.31	89.16	85.92	71.84	8.68
AMPS	29.88	26.98	22.96	17.05	11.75	7.2	4.58

TORQ(FL)#FT	29.6	TORQ(LR)%FL	177.44	TORQ(BD)%FL	235.62
AMPS(LR)	132.76	PF AT START	0.31		

This motor is capable of two cold or one hot start with a maximum connected load inertia of 126 Lb-Ft Sq (5.3 Kg-meter Sq)at 100% voltage, where the load torque varies with the square of the speed. Acceleration time with maximum inertia and the above load type is 46 seconds. Safe stall time at 100% voltage is 79 seconds cold, 64 seconds hot. Rotor inertia is 1.17 Lb-Ft Sq (0.05 Kg-meter Sq).

Open Circuit A-C:	0.981	Short Circuit D-C:	0.013
Short Circuit A-C:	0.034	X/R Ratio:	5.027
Stator Slots:	36	Rotor Slots:	26

Speed Torque Current Curve (First Connection, First Speed)

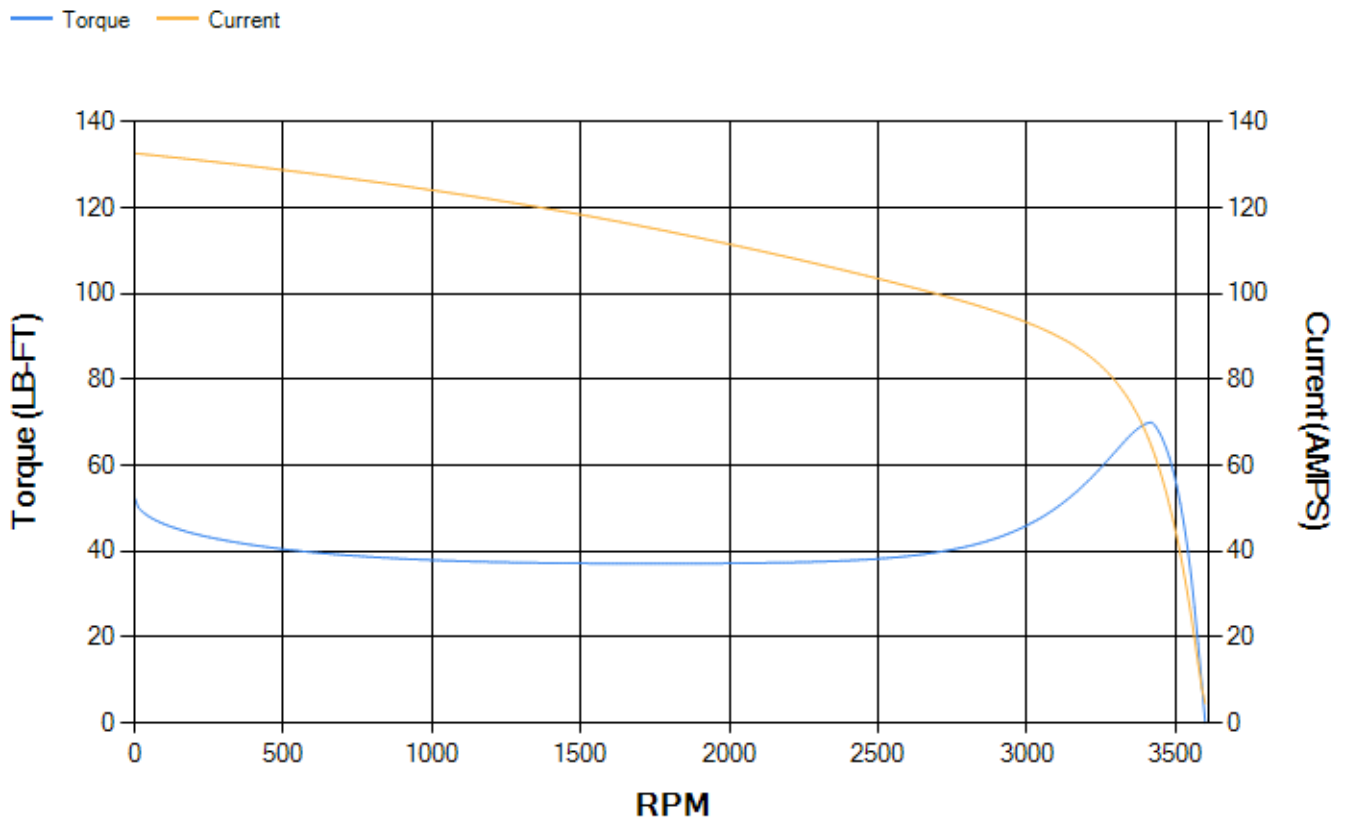

Marks:

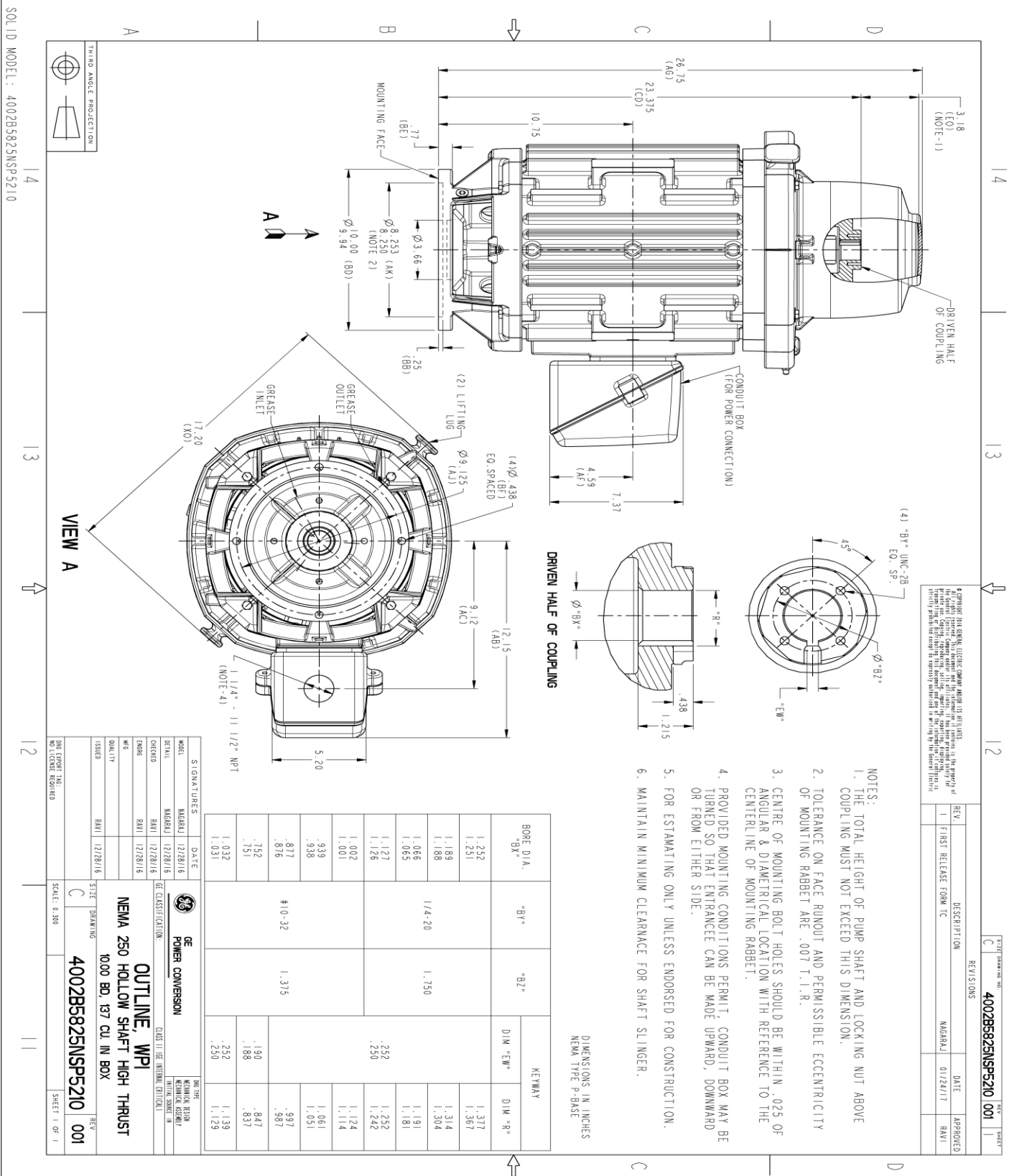

ALL DIMENSIONS UNLESS OTHERWISE SPECIFIED ARE IN INCHES. DIMENSIONS IN PARENTHESES ARE IN MILLIMETERS. DIMENSIONS IN MILLIMETERS ARE NOT TO BE USED AS A BASIS FOR CONSTRUCTION. DIMENSIONS IN PARENTHESES ARE TO BE USED AS A BASIS FOR CONSTRUCTION. DIMENSIONS IN PARENTHESES ARE TO BE USED AS A BASIS FOR CONSTRUCTION.

NOTES:

1. THE TOTAL HEIGHT OF PUMP SHAFT AND LOCKING NUT ABOVE COUPLING MUST NOT EXCEED THIS DIMENSION.
2. TOLERANCE ON FACE RUNOUT AND PERMISSIBLE ECCENTRICITY OF MOUNTING RABBIT ARE .007 T.I.R.
3. CENTRE OF MOUNTING BOLT HOLES SHOULD BE WITHIN .025 OF ANGULAR & DIAMETRICAL LOCATION WITH REFERENCE TO THE CENTERLINE OF MOUNTING RABBIT.
4. PROVIDED MOUNTING CONDITIONS PERMIT, CONDUIT BOX MAY BE TURNED SO THAT ENTRANCE CAN BE MADE UPWARD, DOWNWARD OR FROM EITHER SIDE.
5. FOR ESTIMATING ONLY UNLESS ENDORSED FOR CONSTRUCTION.
6. MAINTAIN MINIMUM CLEARANCE FOR SHAFT SLINGER.

DIMENSIONS IN INCHES
NEMA TYPE P-BASE

BORE DIA. "BX"	"B1"	"B2"	KEYWAY	
			D1W "E"	D1W "R"
1.252			1.377	1.367
1.189			1.314	1.304
1.066	1/4-20	1.750		
1.065				
1.127			.252	1.252
1.126			.250	1.242
1.002				1.124
1.001				1.114
.939				1.061
.877	#10-32	1.375		.997
.876				.987
.752				.847
.751				.837
1.032				252
1.031				1.129

GE POWER CONVERSION

NEMA 250 HOLLOW SHAFT HIGH THRUST
1000 BD, 137 CU IN BOX

4002B5825NSP5210 001

SCALE: 0.300

SHEET 1 OF 1

REV.	DESCRIPTION	DATE	APPROVED
1	FIRST RELEASE FROM TC	01/24/17	RAVI

REVISIONS: 4002B5825NSP5210 001

DATE: 01/24/17

Marks:

Connection Diagram
GEM2034E-FIG9



Heater Connection
3027JE-1C

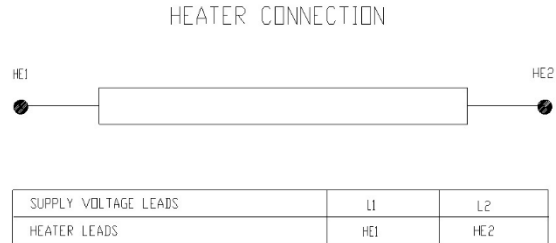

End shield Assembly		
Part Description	DE Side Part#	ODE Side Part#
End Shield	128D6124PA1	128D6128PA1
Bearing	235A2507AC01	235A2507EE01
Slinger/Inproseal	235A2300FL3	

Fan & Fan Cover Assembly	
Part Description	Part#
Fan	
Fan Cover	

Conduit & Accessories Box Assembly	
Part Description	Part#
Conduit Box	4002B5728PA-G04

Mechanical Accessories	
Part Description	Part#
Brake	
Tachometer	

