



**GE INDUSTRIAL MOTORS**  
a **WOLONG** company

# Product Technical Information

December 5, 2020

Data shown is for the current revision model #. Ensure your nameplate model # matches.

<b>Model Number:</b>	<b>5KS254SAE5033A</b>
<b>Catalog Number:</b>	<b>V4025</b>
<b>Instruction Manual:</b>	GEK-95351
<b>Connection Diagram:</b>	GEM2034E-FIG3
<b>Outline Drawing:</b>	4002B5825PSP5317

Accessory Connection Diagrams			
<b>Bearing Thermocouple:</b>	None	<b>Heater:</b>	3027JE-1C
<b>RTD:</b>	None	<b>Thermistor:</b>	None
<b>Thermostat:</b>	None	<b>Winding Thermocouple:</b>	None
<b>Bearing RTD:</b>	None		

## Table of Contents

Specification	01
Performance Characteristics	02
Outline Drawing	03
Connection Drawing(s)	04
Spare parts	05

Marks:

<b>MODEL NUMBER:</b>	<b>5KS254SAE5033A</b>
<b>Outline Drawing:</b>	4002B5825PSP5317
<b>Connection Diagram:</b>	GEM2034E-FIG3
<b>Instruction Book:</b>	GEK-95351
<b>Design Code:</b>	25BD0129A
<b>Type:</b>	KS
<b>Frame:</b>	L254TP10
<b>Phases:</b>	3
<b>Poles:</b>	2
<b>Output Power:</b>	15HP 11.1KW
<b>RPM:</b>	3550
<b>Voltage:</b>	230/460
<b>Hertz:</b>	60
<b>Amps - FL:</b>	34.0/17.0
<b>Service Factor:</b>	1.15
<b>Alt Service Factor:</b>	1.00

<b>Estimated Weight:</b>	315 Lbs
<b>Time Rating:</b>	CONT
<b>Enclosure:</b>	TEFC
<b>Encl Construction:</b>	SD
<b>Ambient Max(°C):</b>	40
<b>Alt Ambient Max(°C):</b>	65
<b>Insulation Class:</b>	H
<b>NEMA Design:</b>	B
<b>Nominal Efficiency:</b>	91.0 %
<b>Guaranteed Efficiency:</b>	89.5 %
<b>3/4 Load Efficiency:</b>	--
<b>KVA Code:</b>	G
<b>Max KVAR:</b>	2.3
<b>Power Factor:</b>	90.5
<b>Bearing - DE:</b>	7309
<b>Bearing - ODE:</b>	6209-2ZC3

**Enclosure is Totally Enclosed Fan-Cooled**

---

**Stamped Nameplate Notes:**

PREMIUM EFFICIENT MOTOR  
 ROT CCW FACING ODE LEAD/PH SEQUENCE 1-2-3/1-2-3  
 HTR LDS HE1-HE2 115V 60W  
 SEVERE DUTY  
 INVERTER DUTY PER NEMA MG1 PART 31  
 ALTERNATE RATING FOR PWM CONTROL:  
 1.0 SF VAR TORQUE RANGE 2.5-60 HZ  
 50HZ DATA:10 HP 190/380 V WITH FLA-27.6/13.8 A



**Additional Information:**

2P - TP EXTN  
C/BOX 137 CU IN-1.25 NPT  
HEATER LEADS EXIT WITH MOTOR LEADS  
E/SHLD GROUND STUD MTD ON DE C/BOX SIDE  
RCF 5000 CPM, STATIC DEFLECTION .0014 INCHES &  
CENTER OF GRAVITY 10.75 INCHES  
HOLLOW SHAFT HIGH THRUST  
NON REV CPLG W/BX=1.00" KW=0.25"  
OIL RESISTANT SLEEVING ON LEADS  
BEARING LIFE 8760 HOURS AT 2048 LB THRUST



**Performance Characteristics**

1st Winding 1st Connection

**Design: 25BD0129A**

**Marks:**

LOAD %	125.0	115.0	100.0	75.0	50.0	25.0	0.0
% EFF	89.96	90.6	91.6	92.26	92.18	89.12	0.00
% PF	89.49	90.08	90.6	90.35	87.42	74.68	11.39
AMPS	21.8	19.78	16.92	12.63	8.71	5.27	3.17

<b>TORQ(FL)#FT</b>	22.18	<b>TORQ(LR)%FL</b>	199.12	<b>TORQ(BD)%FL</b>	253.74
<b>AMPS(LR)</b>	109.26	<b>PF AT START</b>	0.3		

This motor is capable of two cold or one hot start with a maximum connected load inertia of 135 Lb-Ft Sq (5.68 Kg-meter Sq)at 100% voltage, where the load torque varies with the square of the speed. Acceleration time with maximum inertia and the above load type is 58 seconds. Safe stall time at 100% voltage is 102 seconds cold, 69 seconds hot. Rotor inertia is 1.3 Lb-Ft Sq (0.05 Kg-meter Sq).

<b>Open Circuit A-C:</b>	1.089	<b>Short Circuit D-C:</b>	0.014
<b>Short Circuit A-C:</b>	0.032	<b>X/R Ratio:</b>	5.103
<b>Stator Slots:</b>	36	<b>Rotor Slots:</b>	26

**Speed Torque Current Curve (First Connection, First Speed)**

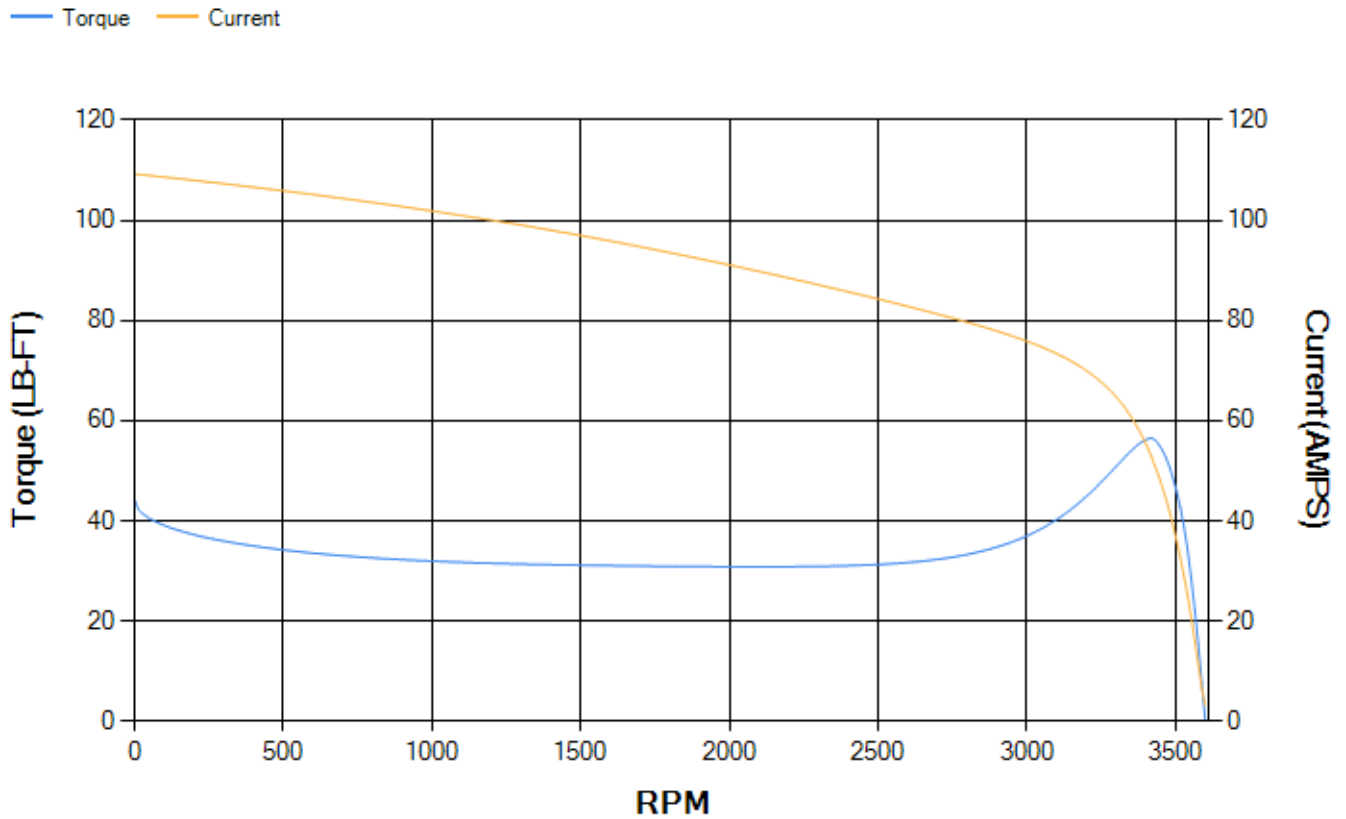

Marks:

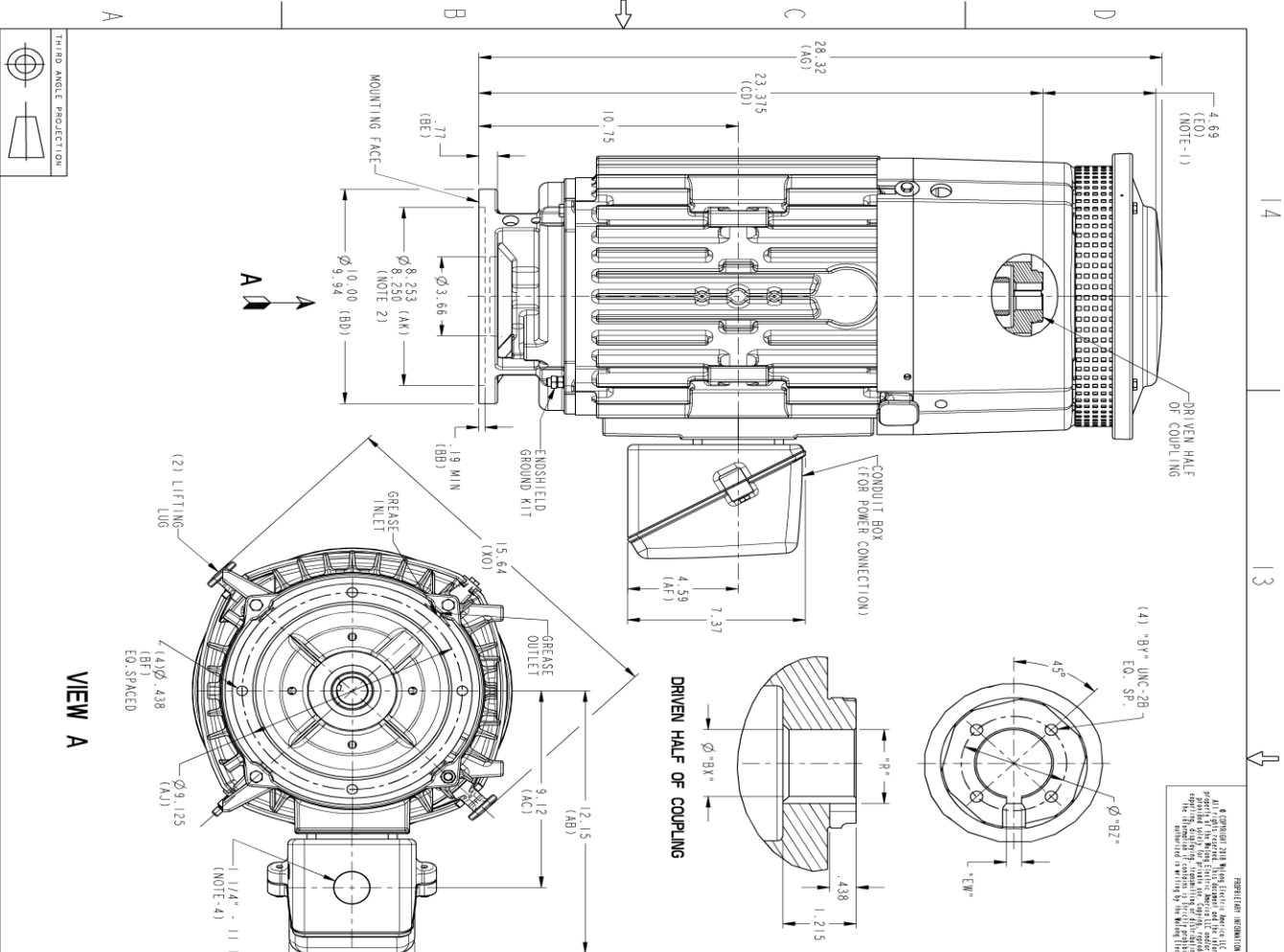

VIEW A

REGISTRATION INFORMATION  
 A copyright 2018 by GE Industrial America LLC under US Patent No. 9,812,111. All rights reserved. This document is the property of GE Industrial America LLC. It is intended for use only in connection with the products and services of GE Industrial America LLC. The information contained herein is confidential and its disclosure to third parties is prohibited without the prior written consent of GE Industrial America LLC.

REV.	DESCRIPTION	DATE	APPROVED

- NOTES:
1. THE TOTAL HEIGHT OF PUMP SHAFT AND LOCKING NUT ABOVE COUPLING MUST NOT EXCEED THIS DIMENSION.
  2. TOLERANCE ON FACE RUNOUT AND PERMISSIBLE ECCENTRICITY OF MOUNTING RABBIT ARE .007 T.I.R.
  3. CENTRE OF MOUNTING BOLT HOLES SHOULD BE WITHIN .025 OF ANGULAR & DIAMETRICAL LOCATION WITH REFERENCE TO THE CENTERLINE OF MOUNTING RABBIT.
  4. PROVIDED MOUNTING CONDITIONS PERMIT, CONDUIT BOX MAY BE TURNED SO THAT ENTRANCE CAN BE MADE UPWARD, DOWNWARD OR FROM EITHER SIDE.
  5. FOR ESTIMATING ONLY UNLESS ENDORSED FOR CONSTRUCTION.
  6. MAINTAIN MINIMUM CLEARANCE FOR SHAFT SLINGER.

DIMENSIONS IN INCHES  
 NEMA TYPE T-BASE

BORE DIA. "Bx"	"By"	"Bz"	KEYWAY	
			DIM "Ew"	DIM "R"
1.252				1.377
1.251				1.367
1.188				1.314
1.065	1/4-20	1.750		1.304
1.127			.252	1.191
1.126			.250	1.181
1.002				1.252
.939				1.124
.938				1.114
.877	#10-32	1.315		1.061
.876				1.051
.752				.987
.751				.987
1.032			.252	1.139
1.031			.250	1.129

**GE INDUSTRIAL MOTORS**  
 a WOLONG company

**OUTLINE, TEFC**  
**NEMA 250 HOLLOW SHAFT HIGH THRUST**  
 1000 BD, 137 CU IN BOX, EXT

SIGNATURES	DATE
MODEL: DEPMANN	11/19/2020
REVIEW: DEPMANN	11/19/2020
CHECKED: BGDH	11/19/2020
DESIGN: DEPMANN	11/19/2020
WIR: DEPMANN	11/19/2020
QUALITY: DEPMANN	11/19/2020

SIZE: DRAWING: C  
 SCALE: 0.300  
 REF. NO.: 4002B5825PSP5317  
 SHEET 1 OF 1

Marks:

**Connection Diagram**  
**GEM2034E-FIG3**



**Heater Connection**  
**3027JE-1C**



End shield Assembly		
Part Description	DE Side Part#	ODE Side Part#
End Shield	128D6129PA1	128D6131PA1
Bearing	235A2507AC01	235A2507EE01
Slinger/Inproseal	235A2300FL3	

Fan & Fan Cover Assembly	
Part Description	Part#
Fan	
Fan Cover	4003C5525AD-G01

Conduit & Accessories Box Assembly	
Part Description	Part#
Conduit Box	4002B5728PA-G04

Mechanical Accessories	
Part Description	Part#
Brake	
Tachometer	

