



GE INDUSTRIAL MOTORS
a **WOLONG** company

Product Technical Information

February 17, 2023

Data shown is for the current revision model #. Ensure your nameplate model # matches.

Model Number:	5KS254DAE6054
Catalog Number:	V4036
Instruction Manual:	GEK-95353
Connection Diagram:	GEM2034E-FIG9
Outline Drawing:	4002B5825NSP5216

Accessory Connection Diagrams

Bearing Thermocouple:	None	Heater:	3027JE-1C
RTD:	None	Thermistor:	None
Thermostat:	None	Winding Thermocouple:	None
Bearing RTD:	None		

Table of Contents

Specification	01
Performance Characteristics	02
Outline Drawing	03
Connection Drawing(s)	04
Spare parts	05

Marks:

MODEL NUMBER:	5KS254DAE6054
Outline Drawing:	4002B5825NSP5216
Connection Diagram:	GEM2034E-FIG9
Instruction Book:	GEK-95353
Design Code:	25BD1120A
Type:	KS
Frame:	L254TP16
Phases:	3
Poles:	4
Output Power:	15HP 11.1KW
RPM:	1775
Voltage:	230/460
Hertz:	60
Amps - FL:	36.0/18.0
Service Factor:	1.15
Alt Service Factor:	--

Estimated Weight:	280 Lbs
Time Rating:	CONT
Enclosure:	WPI
Encl Construction:	OPEN
Ambient Max(°C):	40
Alt Ambient Max(°C):	--
Insulation Class:	H
NEMA Design:	B
Nominal Efficiency:	93.0 %
Guaranteed Efficiency:	91.7 %
3/4 Load Efficiency:	--
KVA Code:	G
Max KVAR:	4.9
Power Factor:	84.0
Bearing - DE:	7309
Bearing - ODE:	6209-2ZC3

Enclosure is Weather Protected One

Stamped Nameplate Notes:

PREMIUM EFFICIENT MOTOR
 NEMA ENCL WPI AND CSA ENCL DP
 ROT CCW FACING ODE LEAD/PH SEQUENCE 1-2-3/1-2-3
 HTR LDS HE1-HE2 115V 60W
 INVERTER DUTY PER NEMA MG1 PART 31
 ALTERNATE RATING FOR PWM CONTROL:
 1.0 SF VAR TORQUE RANGE 5-60 HZ
 SUITABLE FOR 10HP, 190/380V,
 50 HZ WITH 29.8/14.9AMPS AND 1480 RPM AT 1.0 SF



Additional Information:

4P - TP EXTN
C/BOX 137 CU IN-1.25 NPT
AUX LEADS EXIT WITH MOTOR LEADS
RCF 5000 CPM, STATIC DEFLECTION .0014 INCHES &
CENTER OF GRAVITY 10.75 INCHES
HOLLOW SHAFT HIGH THRUST
NON REV CPLG W/BX=1.25" KW=0.25"
OIL RESISTANT SLEEVING ON LEADS
BEARING LIFE 8760 HOURS AT 2574 LB THRUST



Performance Characteristics

1st Winding 1st Connection

Design: 25BD1120A

Marks:

LOAD %	125.0	115.0	100.0	75.0	50.0	25.0	0.0
% EFF	92.04	92.45	93.16	93.46	93.19	90.22	0.00
% PF	85.57	85.17	84.04	80.02	70.62	48.52	4.76
AMPS	22.28	20.51	17.93	14.08	10.67	8.02	6.77

TORQ(FL)#FT	44.35	TORQ(LR)%FL	191.62	TORQ(BD)%FL	250.39
AMPS(LR)	99.56	PF AT START	0.45		

This motor is capable of two cold or one hot start with a maximum connected load inertia of 529 Lb-Ft Sq (22.27 Kg-meter Sq)at 100% voltage, where the load torque varies with the square of the speed. Acceleration time with maximum inertia and the above load type is 49 seconds. Safe stall time at 100% voltage is 108 seconds cold, 87 seconds hot. Rotor inertia is 2.29 Lb-Ft Sq (0.1 Kg-meter Sq).

Open Circuit A-C:	0.509	Short Circuit D-C:	0.014
Short Circuit A-C:	0.027	X/R Ratio:	5.15
Stator Slots:	48	Rotor Slots:	40

Speed Torque Current Curve (First Connection, First Speed)

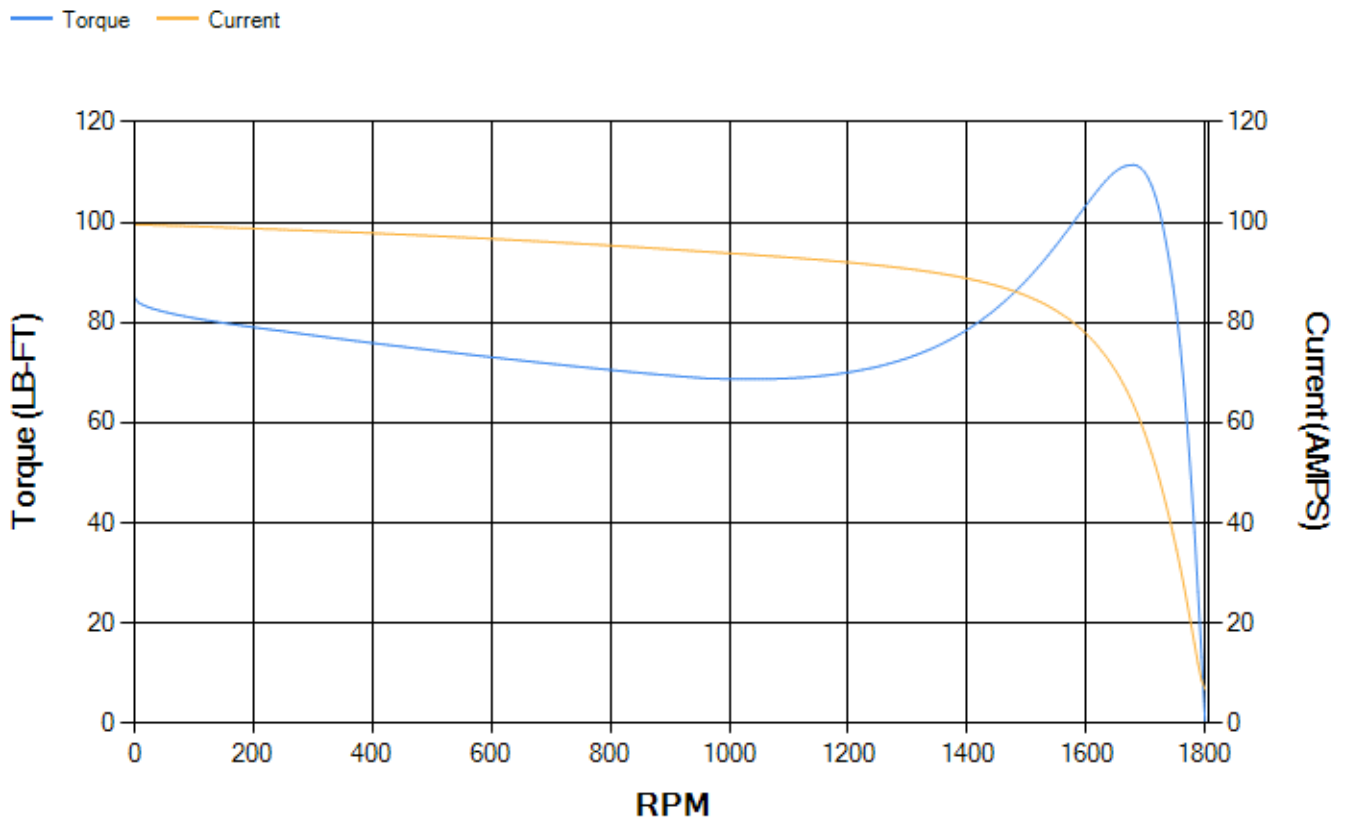

Marks:

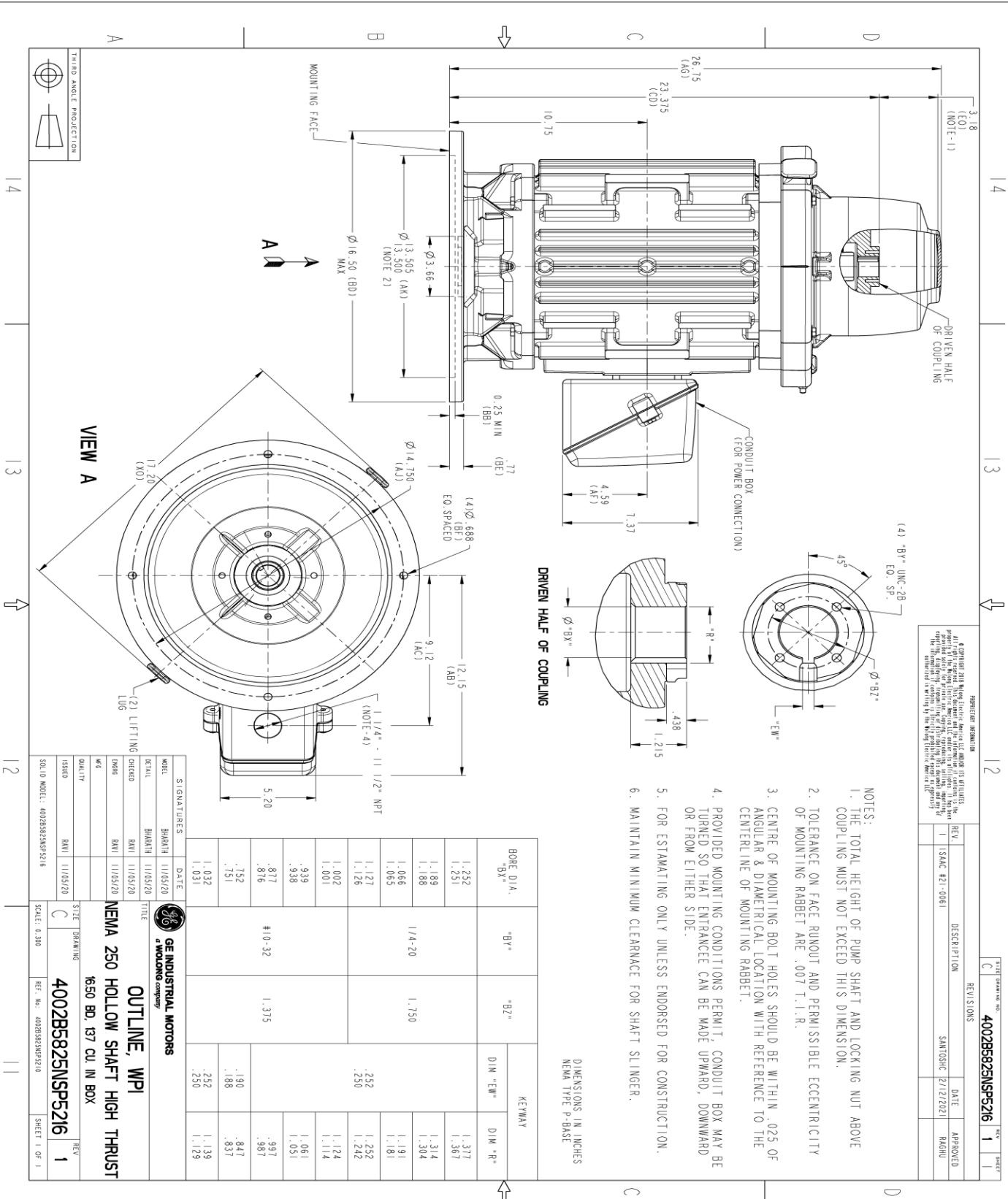

REVISION INFORMATION

REV.	DESCRIPTION	DATE	APPROVED
1	ISAC #21-0061	2/17/2021	RAMRO

4002B5825NSP5216 1 1

- NOTES:
1. THE TOTAL HEIGHT OF PUMP SHAFT AND LOCKING NUT ABOVE COUPLING MUST NOT EXCEED THIS DIMENSION.
 2. TOLERANCE ON FACE RUNOUT AND PERMISSIBLE ECCENTRICITY OF MOUNTING RABBIT ARE .007 T.I.R.
 3. CENTRE OF MOUNTING BOLT HOLES SHOULD BE WITHIN .025 OF ANGULAR & DIAMETRICAL LOCATION WITH REFERENCE TO THE CENTERLINE OF MOUNTING RABBIT.
 4. PROVIDED MOUNTING CONDITIONS PERMIT, CONDUIT BOX MAY BE TURNED SO THAT ENTRANCEE CAN BE MADE UPWARD, DOWNWARD OR FROM EITHER SIDE.
 5. FOR ESTIMATING ONLY UNLESS ENDORSED FOR CONSTRUCTION.
 6. MAINTAIN MINIMUM CLEARANCE FOR SHAFT SLINGER.

DIMENSIONS IN INCHES
NEMA TYPE P-BASE

BORE DIA. Bx	"Bx"	"Bz"	KEYWAY	
			DIM "Ew"	DIM "R"
1.252				1.377
1.231				1.367
1.189				1.314
1.188	1/4-20	1.750		1.304
1.066				1.191
1.065				1.181
1.127			.252	1.252
1.128			.250	1.242
1.002				1.124
1.001				1.114
.938				1.061
.938				1.051
.877	#10-32	1.375		.997
.876				.987
.752			.190	.847
.751			.188	.837
1.032			.252	1.139
1.031			.250	1.129

GE INDUSTRIAL MOTORS
a WOLONG company

OUTLINE, WPI
1650 BD, 137 CU, IN BOX

4002B5825NSP5216 1

SIGNATURES	DATE
SHAFT	11/05/22
RETAIN	11/05/22
RAM	11/05/22
RAM	11/05/22
RAM	11/05/22
RAM	11/05/22

SCALE: 0.500

SHEET 1 OF 1

Marks:

Connection Diagram
GEM2034E-FIG9



Heater Connection
3027JE-1C



End shield Assembly		
Part Description	DE Side Part#	ODE Side Part#
End Shield	128D6126PA1	128D6128PA1
Bearing	235A2507AC01	235A2507EE01
Slinger/Inproseal	235A2300FL3	

Fan & Fan Cover Assembly	
Part Description	Part#
Fan	
Fan Cover	

Conduit & Accessories Box Assembly	
Part Description	Part#
Conduit Box	4002B5728PA-G04

Mechanical Accessories	
Part Description	Part#
Brake	
Tachometer	

