



GE INDUSTRIAL MOTORS
a **WOLONG** company

Product Technical Information

July 15, 2020

Data shown is for the current revision model #. Ensure your nameplate model # matches.

Model Number:	5KS324DAJ5005C
Catalog Number:	V4210
Instruction Manual:	GEI-M1045
Connection Diagram:	GEM2034E-FIG9
Outline Drawing:	148CB32VMHKBCAA0001

Accessory Connection Diagrams

Bearing Thermocouple:	None	Heater:	3027JE-1C
RTD:	None	Thermistor:	None
Thermostat:	None	Winding Thermocouple:	None
Bearing RTD:	None		

Table of Contents

Specification	01
Performance Characteristics	02
Outline Drawing	03
Connection Drawing(s)	04
Spare parts	05

Marks:

MODEL NUMBER:	5KS324DAJ5005C	Estimated Weight:	680 Lbs
Outline Drawing:	148CB32VMHKBAA0001	Time Rating:	CONT
Connection Diagram:	GEM2034E-FIG9	Enclosure:	WPI
Instruction Book:	GEI-M1045	Encl Construction:	OPEN
Design Code:	32BD0145AA	Ambient Max(°C):	40
Type:	KS	Alt Ambient Max(°C):	--
Frame:	L324TP16	Insulation Class:	H
Phases:	3	NEMA Design:	B
Poles:	2	Nominal Efficiency:	93.0 %
Output Power:	50HP 37KW	Guaranteed Efficiency:	91.7 %
RPM:	3565	3/4 Load Efficiency:	--
Voltage:	230/460	KVA Code:	G
Hertz:	60	Max KVAR:	16.0
Amps - FL:	120.0/60.0	Power Factor:	85.0
Service Factor:	1.15	Bearing - DE:	6212C3
Alt Service Factor:	--	Bearing - ODE:	235A2523AD01

Enclosure is Weather Protected One

Stamped Nameplate Notes:

NEMA ENCLOSURE WP-I, CSA ENCL DP
 HTR LDS HE1-HE2 115V 100W
 ROT CCW FACING ODE LEAD/PH SEQ 1-2-3/1-2-3
 INVERTER DUTY PER NEMA MG1 PART 31
 ALTERNATE RATING FOR PWM CONTROL:1.0SF 40C AMBIENT
 VAR TORQUE RANGE 2.5-60 HZ
 UPPER BRG LUBE OIL: 2.1 QTS
 0 DEG C TO 40 DEG C : ISO 32(MINERAL OR SYNTHETIC)
 -15 DEG C TO 0 DEG C : ISO 32 SYNTHETIC
 SUITABLE FOR 40 HP, 190/380V, 50 HZ WITH
 114.6/57.3 AMPS AND 2970 RPM AT 1.0 SF



Additional Information:

2P, VERT HOLLOW SHAFT HIGH THRUST (1D)
SPECIAL BALANCE
C/BOX 346 CU IN - 3.00" NPT
OIL RESISTANT SLEEVING ON LEADS
115V HTR LDS TO MAIN CONDUIT BOX
BEARING LIFE 8760 HRS AT 5273 LB THRUST
CG:13.86 IN FROM P-BASE FACE, STAT DEF:0.0023 IN
RCF:3840 CPM AT C/BOX SIDE, 4020 CPM AT
90 DEG FROM C/ BOX SIDE
NON-REVERSE BALL CARRIER,
BOLTED COUPLING, BX = 1.001", KEY=0.25"



Performance Characteristics

1st Winding 1st Connection

Design: 32BD0145AA

Marks:

LOAD %	125.0	115.0	100.0	75.0	50.0	25.0	0.0
% EFF	91.86	92.02	92.34	91.86	90.36	84.65	0.00
% PF	86.44	86.01	84.9	81.03	72.09	51.06	8.41
AMPS	73.67	67.99	59.6	47.15	35.92	27.07	22.5

TORQ(FL)#FT	73.59	TORQ(LR)%FL	139.57	TORQ(BD)%FL	266.46
AMPS(LR)	339.68	PF AT START	0.3		

This motor is capable of two cold or one hot start with a maximum connected load inertia of 157 Lb-Ft Sq (6.61 Kg-meter Sq)at 100% voltage, where the load torque varies with the square of the speed. Acceleration time with maximum inertia and the above load type is 27 seconds. Safe stall time at 100% voltage is 45 seconds cold, 33 seconds hot. Rotor inertia is 3.47 Lb-Ft Sq (0.15 Kg-meter Sq).

Open Circuit A-C:	0.739	Short Circuit D-C:	0.019
Short Circuit A-C:	0.047	X/R Ratio:	7.116
Stator Slots:	48	Rotor Slots:	38

Speed Torque Current Curve (First Connection, First Speed)

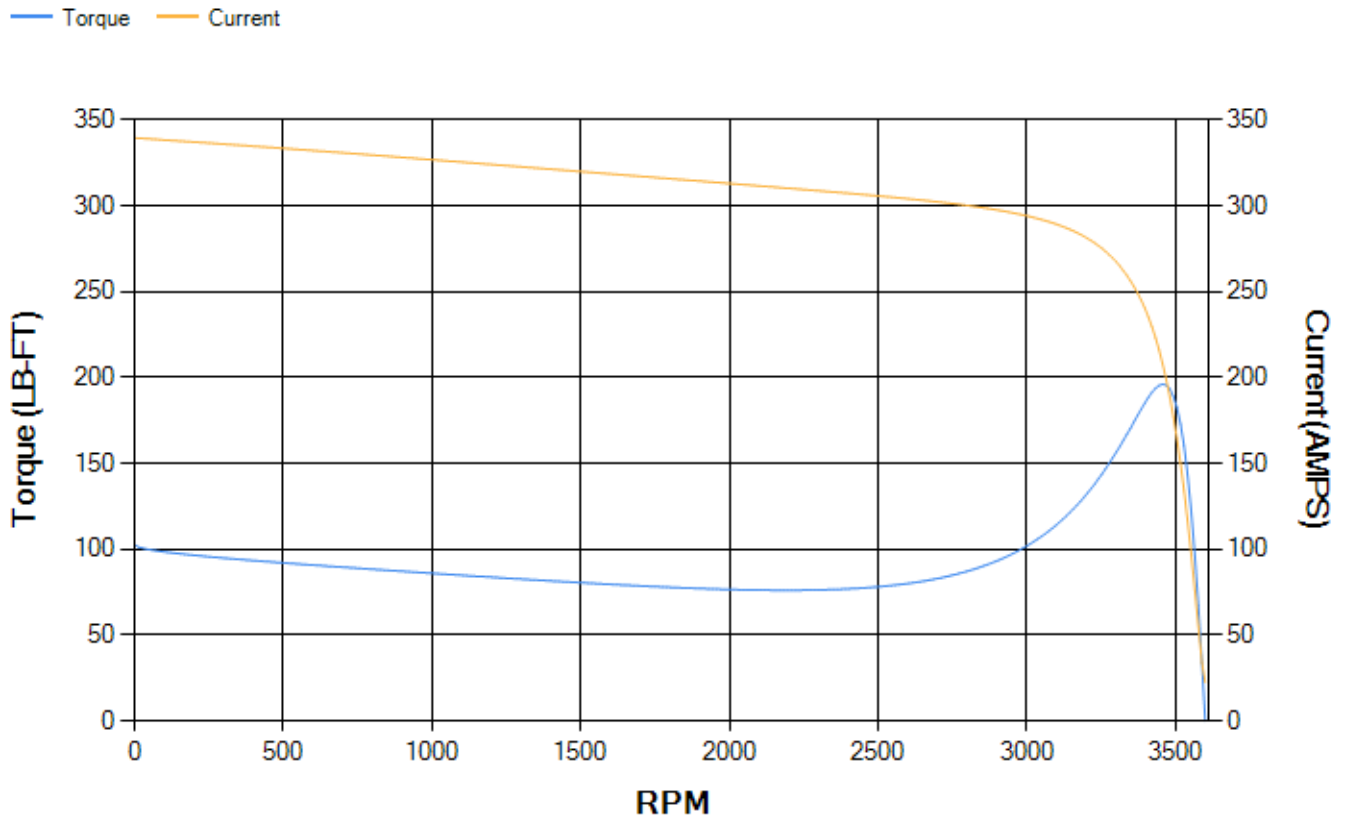

Marks:

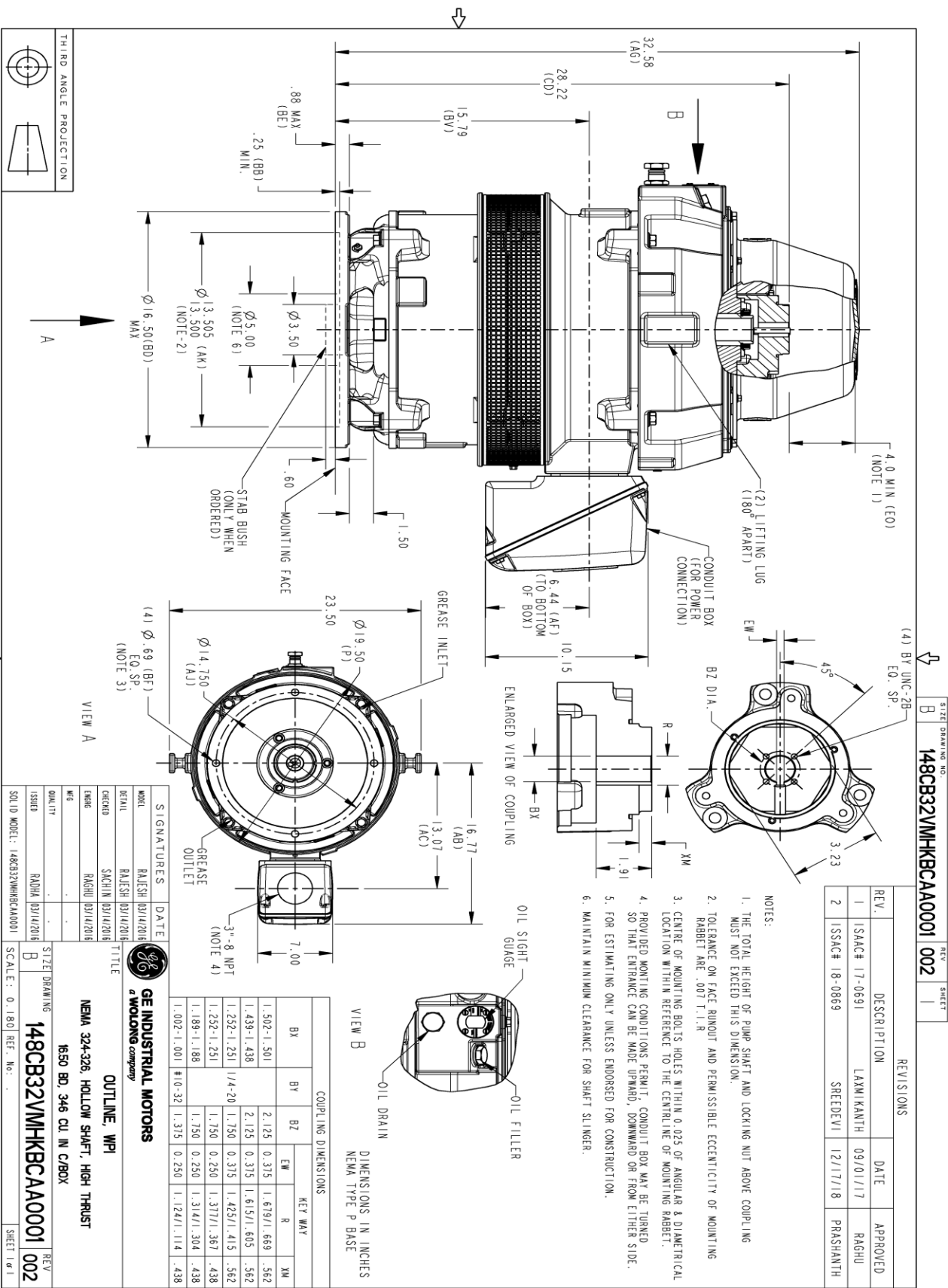

Marks:

Connection Diagram
GEM2034E-FIG9



Heater Connection
3027JE-1C



End shield Assembly		
Part Description	DE Side Part#	ODE Side Part#
End Shield	115E7205AA1	115E7208LJ1
Bearing	235A2509BE01	235A2523AD01
Slinger/Inproseal	235A2300FM1	

Fan & Fan Cover Assembly	
Part Description	Part#
Fan	
Fan Cover	161C1052AA1

Conduit & Accessories Box Assembly	
Part Description	Part#
Conduit Box	149C4429AA2

Mechanical Accessories	
Part Description	Part#
Brake	
Tachometer	

