



GE INDUSTRIAL MOTORS
a **WOLONG** company

Product Technical Information

July 15, 2020

Data shown is for the current revision model #. Ensure your nameplate model # matches.

Model Number:	5KS405DAJ6008D1
Catalog Number:	V4424
Instruction Manual:	GEI-M1045
Connection Diagram:	GEM2034E-FIG19
Outline Drawing:	148CB40VMHKCCAA0001

Accessory Connection Diagrams

Bearing Thermocouple:	None	Heater:	3027JE-1C
RTD:	None	Thermistor:	None
Thermostat:	None	Winding Thermocouple:	None
Bearing RTD:	None		

Table of Contents

Specification	01
Performance Characteristics	02
Outline Drawing	03
Connection Drawing(s)	04
Spare parts	05

Marks:

MODEL NUMBER:	5KS405DAJ6008D1	Estimated Weight:	1150 Lbs
Outline Drawing:	148CB40VMHKCCAA0001	Time Rating:	CONT
Connection Diagram:	GEM2034E-FIG19	Enclosure:	WPI
Instruction Book:	GEI-M1045	Encl Construction:	OPEN
Design Code:	40BD1168AA	Ambient Max(°C):	40
Type:	KS	Alt Ambient Max(°C):	--
Frame:	L405TP16	Insulation Class:	H
Phases:	3	NEMA Design:	B
Poles:	4	Nominal Efficiency:	95.4 %
Output Power:	125HP 92.5KW	Guaranteed Efficiency:	94.5 %
RPM:	1780	3/4 Load Efficiency:	94.9 %
Voltage:	460	KVA Code:	G
Hertz:	60	Max KVAR:	41.6
Amps - FL:	148.0	Power Factor:	83.5
Service Factor:	1.15	Bearing - DE:	6215C3
Alt Service Factor:	--	Bearing - ODE:	235A2532AA01

Enclosure is Weather Protected One

Stamped Nameplate Notes:

NEMA ENCLOSURE WP-I, CSA ENCL DP
HTR LDS HE1-HE2 115V 100W
ROT CCW FACING ODE LEAD/PH SEQ 1-2-3/1-2-3
INVERTER DUTY PER NEMA MG1 PART 31
ALTERNATE RATING FOR PWM CONTROL:1.0SF 40C AMBIENT
VAR TORQUE RANGE 5 -60 HZ
UPPER BRG LUBE OIL: 6 QTS
0 DEG C TO 40 DEG C : ISO 32(MINERAL OR SYNTHETIC)
-15 DEG C TO 0 DEG C : ISO 32 SYNTHETIC
SUITABLE FOR 100 HP, 380V, 50 HZ WITH
144.0 AMPS AND 1480 RPM AT 1.0 SF



Additional Information:

4P, VERT HOLLOW SHAFT HIGH THRUST (1D)
C/BOX 700 CU IN - 3.00" NPT
SPECIAL BALANCE
OIL RESISTANT SLEEVING ON LEADS
115V HTR LDS TO MAIN CONDUIT BOX
BEARING LIFE 8760 HRS AT 7539 LB THRUST
PART WINDING START
CG:18.50 IN FROM P-BASE FACE, STAT DEF:0.0032 IN
RCF:3240 CPM AT C/BOX SIDE, 3360 CPM AT
90 DEG FROM C/ BOX SIDE
NON-REVERSE BALL CARRIER,
BOLTED COUPLING, BX = 1.501
COMMON FOR STD STOCK AS WELL AS FIRE PUMP



Performance Characteristics

1st Winding 1st Connection

Design: 40BD1168AA

Marks:

LOAD %	125.0	115.0	100.0	75.0	50.0	25.0	0.0
% EFF	94.1	94.35	94.86	94.91	94.51	91.82	0.00
% PF	85.17	84.69	83.45	79.19	69.41	46.93	3.79
AMPS	182.47	168.36	147.79	116.75	89.17	67.87	58.14

TORQ(FL)#FT	368.49	TORQ(LR)%FL	144.58	TORQ(BD)%FL	249.01
AMPS(LR)	801.19	PF AT START	0.31		

This motor is capable of two cold or one hot start with a maximum connected load inertia of 1877 Lb-Ft Sq (79.02 Kg-meter Sq)at 100% voltage, where the load torque varies with the square of the speed. Acceleration time with maximum inertia and the above load type is 28 seconds. Safe stall time at 100% voltage is 62 seconds cold, 33 seconds hot. Rotor inertia is 21.53 Lb-Ft Sq (0.91 Kg-meter Sq).

Open Circuit A-C:	0.609	Short Circuit D-C:	0.024
Short Circuit A-C:	0.04	X/R Ratio:	9.151
Stator Slots:	72	Rotor Slots:	58

Speed Torque Current Curve (First Connection, First Speed)

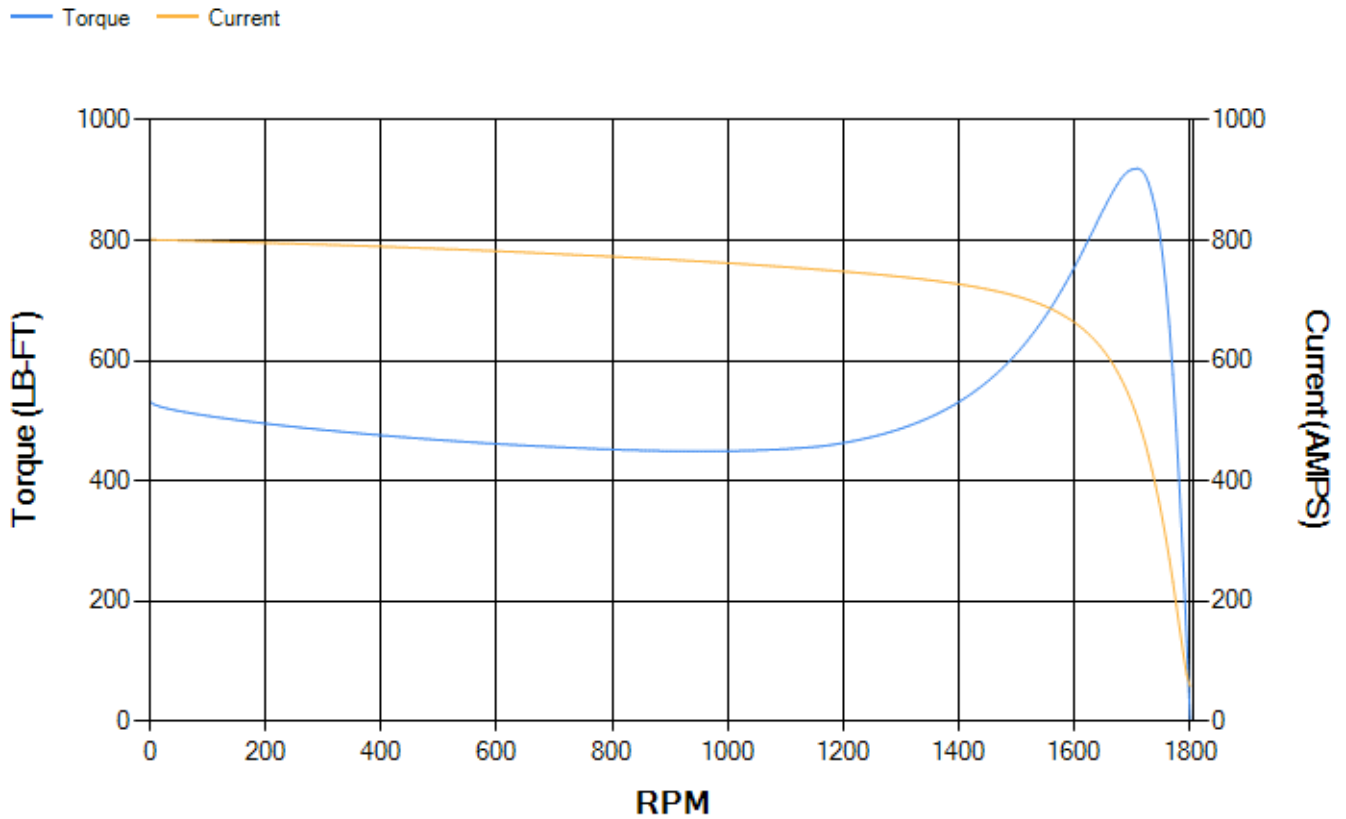

Marks:

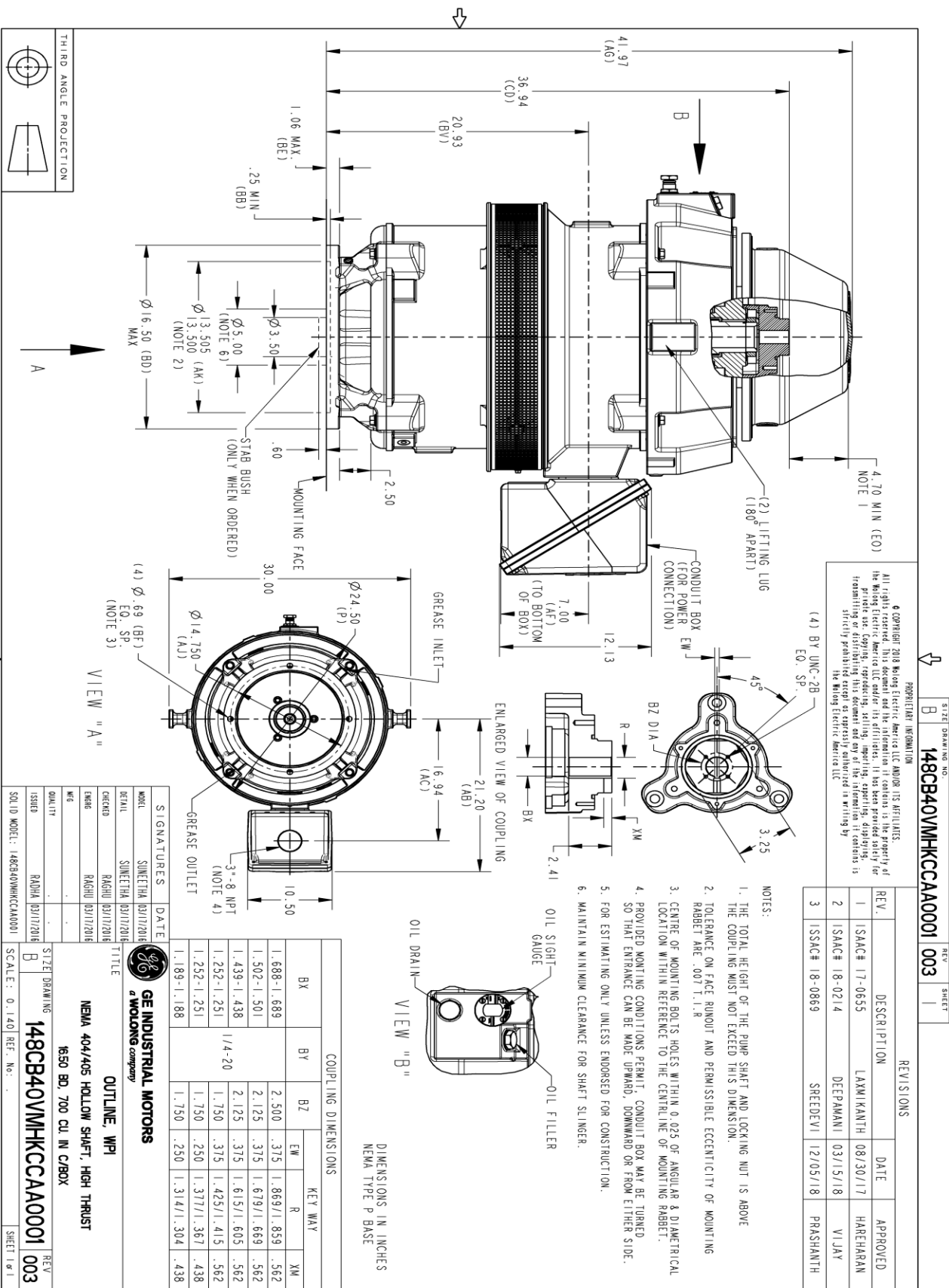

Marks:

Connection Diagram
GEM2034E-FIG19



Heater Connection
3027JE-1C



End shield Assembly		
Part Description	DE Side Part#	ODE Side Part#
End Shield	115E7306AC1	115E7310LJ1
Bearing	235A2513AL01	235A2532AA01
Slinger/Inproseal	235A2300HW1	

Fan & Fan Cover Assembly	
Part Description	Part#
Fan	
Fan Cover	161C1054AA1

Conduit & Accessories Box Assembly	
Part Description	Part#
Conduit Box	118D4408AD2

Mechanical Accessories	
Part Description	Part#
Brake	
Tachometer	

