



GE INDUSTRIAL MOTORS
a **WOLONG** company

Product Technical Information

February 17, 2023

Data shown is for the current revision model #. Ensure your nameplate model # matches.

Model Number:	5KS324DAJ6057
Catalog Number:	V4457
Instruction Manual:	GEI-M1045
Connection Diagram:	GEM2034E-FIG9
Outline Drawing:	148CB32VMHKBCAA0001

Accessory Connection Diagrams

Bearing Thermocouple:	None	Heater:	3027JE-1C
RTD:	None	Thermistor:	None
Thermostat:	None	Winding Thermocouple:	None
Bearing RTD:	None		

Table of Contents

Specification	01
Performance Characteristics	02
Outline Drawing	03
Connection Drawing(s)	04
Spare parts	05

Marks:

MODEL NUMBER:	5KS324DAJ6057	Estimated Weight:	690 Lbs
Outline Drawing:	148CB32VMHKBCAA0001	Time Rating:	CONT
Connection Diagram:	GEM2034E-FIG9	Enclosure:	WPI
Instruction Book:	GEI-M1045	Encl Construction:	OPEN
Design Code:	32BD1310AA	Ambient Max(°C):	40
Type:	KS	Alt Ambient Max(°C):	--
Frame:	L324TP16	Insulation Class:	H
Phases:	3	NEMA Design:	B
Poles:	4	Nominal Efficiency:	94.1 %
Output Power:	40HP 29.6KW	Guaranteed Efficiency:	93.0 %
RPM:	1780	3/4 Load Efficiency:	--
Voltage:	200-230/460	KVA Code:	G
Hertz:	60	Max KVAR:	15.3
Amps - FL:	112-100/50	Power Factor:	80.0
Service Factor:	1.15	Bearing - DE:	6212C3
Alt Service Factor:	--	Bearing - ODE:	235A2523AD01

Enclosure is Weather Protected One

Stamped Nameplate Notes:

NEMA ENCLOSURE WP-I, CSA ENCL DP
HTR LDS HE1-HE2 115V 100W
ROT CCW FACING ODE LEAD/PH SEQ 1-2-3/1-2-3
INVERTER DUTY PER NEMA MG1 PART 31
ALTERNATE RATING FOR PWM CONTROL:1.0SF 40C AMBIENT
VAR TORQUE RANGE 5 -60 HZ
UPPER BRG LUBE OIL: 2.1 QTS
AMB 0 TO 40 DEG C : ISO 32(MINERAL OR SYNTHETIC)
AMB -15 TO 0 DEG C : ISO 32 SYNTHETIC
SUITABLE FOR 30 HP, 190/380V, 50 HZ WITH
92.0/46.0 AMPS AND 1480 RPM AT 1.00 SF



Additional Information:

4P, VERT HOLLOW SHAFT HIGH THRUST (1D)
C/BOX 346 CU IN - 3.00" NPT
OIL RESISTANT SLEEVING ON LEADS
115V HTR LDS TO MAIN CONDUIT BOX
BEARING LIFE 8760 HRS AT 6324 LB THRUST
CG:13.86 IN FROM P-BASE FACE, STAT DEF:0.0025 IN
RCF:3600 CPM AT C/BOX SIDE, 3870 CPM AT
90 DEG FROM C/ BOX SIDE
NON-REVERSE BALL CARRIER,
BOLTED COUPLING, BX = 1.188 IN, EW= 0.250 IN
FIRE PUMP MOTOR
ESTIMATED SOUND PRESSURE < 80 DBA AT 1 METER



Performance Characteristics

1st Winding 1st Connection

Design: 32BD1310AA

Marks:

LOAD %	125.0	115.0	100.0	75.0	50.0	25.0	0.0
% EFF	93.15	93.4	93.87	93.76	92.99	89.16	0.00
% PF	81.8	81.26	79.84	75.05	64.65	42.77	4.51
AMPS	61.41	56.73	49.84	39.9	31.14	24.54	21.35

TORQ(FL)#FT	118.01	TORQ(LR)%FL	157.38	TORQ(BD)%FL	236.32
AMPS(LR)	261.24	PF AT START	0.33		

This motor is capable of two cold or one hot start with a maximum connected load inertia of 1174 Lb-Ft Sq (49.43 Kg-meter Sq) at 100% voltage, where the load torque varies with the square of the speed. Acceleration time with maximum inertia and the above load type is 51 seconds. Safe stall time at 100% voltage is 87 seconds cold, 61 seconds hot. Rotor inertia is 6.63 Lb-Ft Sq (0.28 Kg-meter Sq).

Open Circuit A-C:	0.514	Short Circuit D-C:	0.024
Short Circuit A-C:	0.035	X/R Ratio:	8.887
Stator Slots:	48	Rotor Slots:	38

Speed Torque Current Curve (First Connection, First Speed)

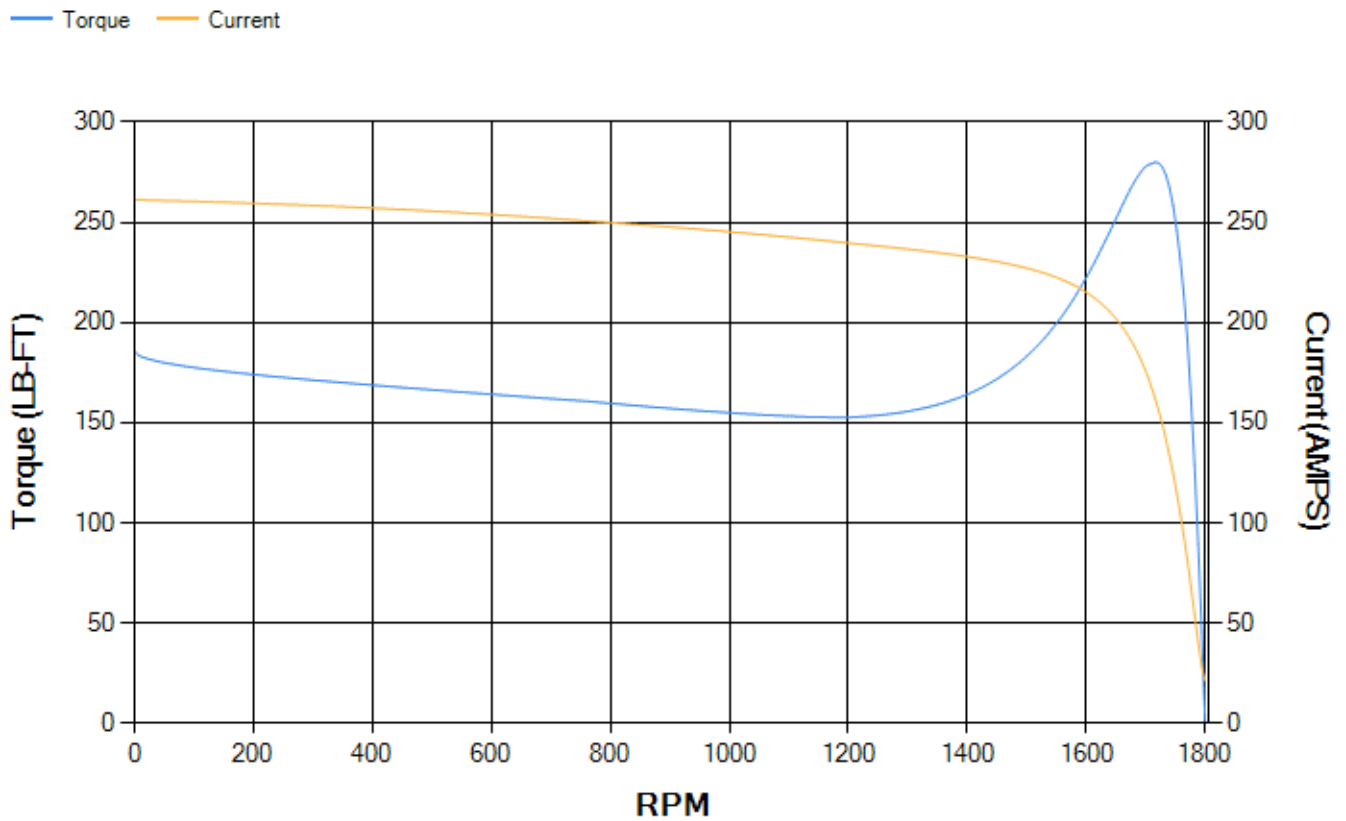

Marks:

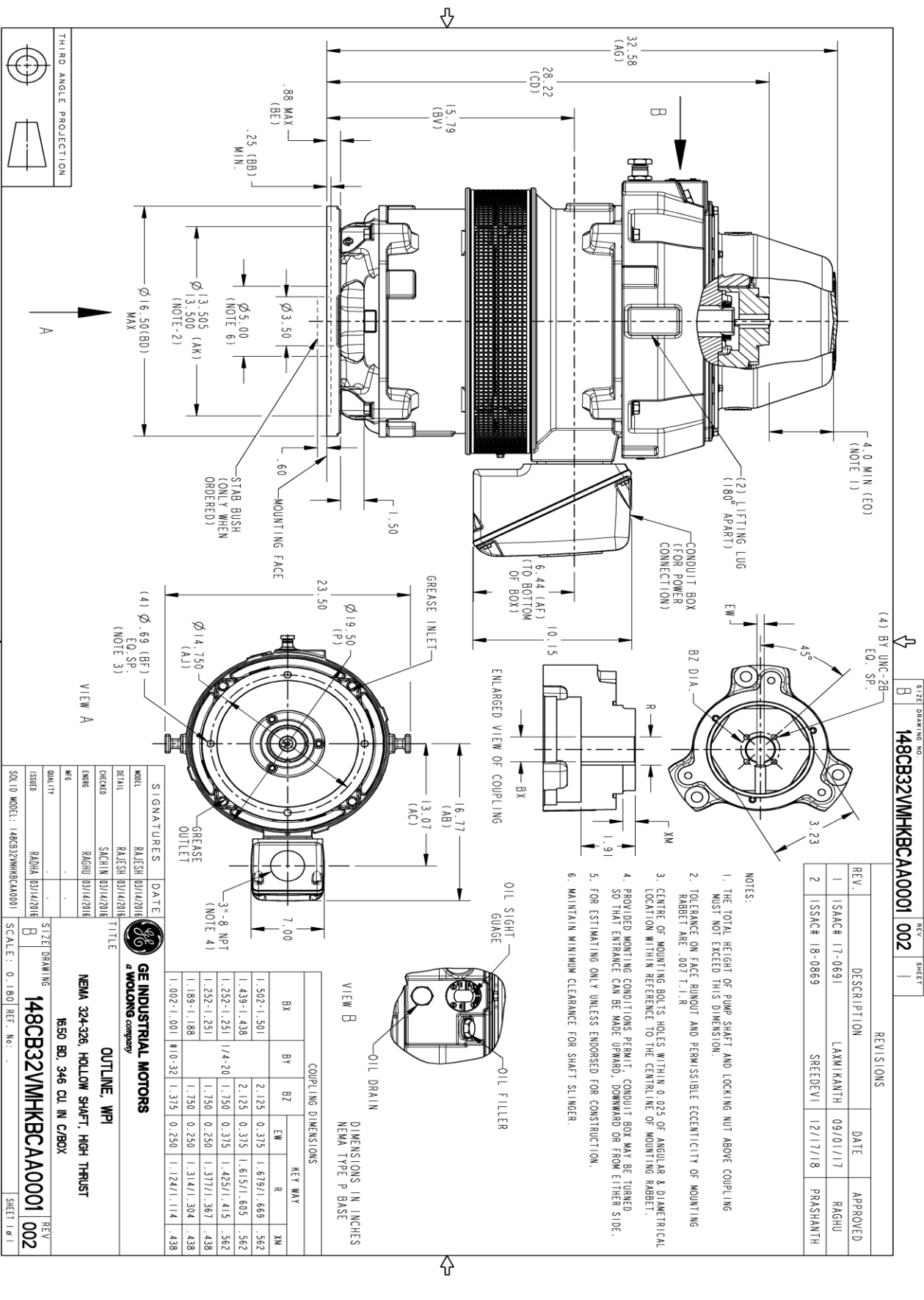

Marks:

Connection Diagram
GEM2034E-FIG9



Heater Connection
3027JE-1C



End shield Assembly		
Part Description	DE Side Part#	ODE Side Part#
End Shield	115E7205AA1	115E7208LK-G01
Bearing	235A2509BE01	235A2523AD01
Slinger/Inproseal	235A2300FM1	

Fan & Fan Cover Assembly	
Part Description	Part#
Fan	
Fan Cover	161C1052AA1

Conduit & Accessories Box Assembly	
Part Description	Part#
Conduit Box	149C4429AA2

Mechanical Accessories	
Part Description	Part#
Brake	
Tachometer	

