



GE INDUSTRIAL MOTORS
a **WOLONG** company

Product Technical Information

February 17, 2023

Data shown is for the current revision model #. Ensure your nameplate model # matches.

Model Number:	5KS365DAJ6079
Catalog Number:	V4470
Instruction Manual:	GEI-M1045
Connection Diagram:	GEM2034E-FIG9
Outline Drawing:	148CB36VMHKCCAA0003

Accessory Connection Diagrams

Bearing Thermocouple:	None	Heater:	3027JE-1C
RTD:	None	Thermistor:	None
Thermostat:	None	Winding Thermocouple:	None
Bearing RTD:	None		

Table of Contents

Specification	01
Performance Characteristics	02
Outline Drawing	03
Connection Drawing(s)	04
Spare parts	05

Marks:

MODEL NUMBER:	5KS365DAJ6079	Estimated Weight:	830 Lbs
Outline Drawing:	148CB36VMHKCCAA0003	Time Rating:	CONT
Connection Diagram:	GEM2034E-FIG9	Enclosure:	WPI
Instruction Book:	GEI-M1045	Encl Construction:	OPEN
Design Code:	36BD1237AA	Ambient Max(°C):	40
Type:	KS	Alt Ambient Max(°C):	--
Frame:	L365TP16	Insulation Class:	H
Phases:	3	NEMA Design:	B
Poles:	4	Nominal Efficiency:	95.0 %
Output Power:	75HP 55.5KW	Guaranteed Efficiency:	94.1 %
RPM:	1785	3/4 Load Efficiency:	--
Voltage:	200-230/460	KVA Code:	G
Hertz:	60	Max KVAR:	27.8
Amps - FL:	202-183.4/91.7	Power Factor:	81.0
Service Factor:	1.15	Bearing - DE:	6212C3
Alt Service Factor:	--	Bearing - ODE:	235A2523AD01

Enclosure is Weather Protected One

Stamped Nameplate Notes:

NEMA ENCLOSURE WP-I, CSA ENCL DP
HTR LDS HE1-HE2 115V 100W
ROT CCW FACING ODE LEAD/PH SEQ 1-2-3/1-2-3
INVERTER DUTY PER NEMA MG1 PART 31
ALTERNATE RATING FOR PWM CONTROL:1.0SF 40C AMBIENT
VAR TORQUE RANGE 5-60 HZ
UPPER BRG LUBE OIL: 3.7 QTS
AMB 0 TO 40 DEG C : ISO 32(MINERAL OR SYNTHETIC)
AMB -15 TO 0 DEG C : ISO 32 SYNTHETIC
SUITABLE FOR 60 HP, 190/380V, 50 HZ,
178.0/88.8 AMPS AND 1485 RPM AT 1.0 SF



Additional Information:

4P, VERT HOLLOW SHAFT HIGH THRUST (1D)
C/BOX 700 CU IN - 3.00" NPT
OIL RESISTANT SLEEVING ON LEADS
115V HTR LDS TO MAIN CONDUIT BOX
BEARING LIFE 8760 HRS AT 6244 LB THRUST
CG:15.23 IN FROM P-BASE FACE, STAT DEF:0.0033 IN
RCF:3300 CPM AT C/BOX SIDE, 3270 CPM AT
90 DEG FROM C/ BOX SIDE
NON-REVERSE BALL CARRIER,
BOLTED COUPLING, BX = 1.501 IN, EW= 0.375 IN
FIRE PUMP MOTOR
ESTIMATED SOUND PRESSURE < 80 DBA@ 1 METER



Performance Characteristics

1st Winding 1st Connection

Design: 36BD1237AA

Marks:

LOAD %	125.0	115.0	100.0	75.0	50.0	25.0	0.0
% EFF	94.18	94.39	94.83	94.74	94.15	91.01	0.00
% PF	83.3	82.68	81.16	76.27	65.72	43.3	3.71
AMPS	111.84	103.44	90.98	72.85	56.73	44.53	38.77

TORQ(FL)#FT	220.86	TORQ(LR)%FL	162.11	TORQ(BD)%FL	257.68
AMPS(LR)	513.21	PF AT START	0.31		

This motor is capable of two cold or one hot start with a maximum connected load inertia of 1597 Lb-Ft Sq (67.23 Kg-meter Sq) at 100% voltage, where the load torque varies with the square of the speed. Acceleration time with maximum inertia and the above load type is 35 seconds. Safe stall time at 100% voltage is 64 seconds cold, 42 seconds hot. Rotor inertia is 12.61 Lb-Ft Sq (0.53 Kg-meter Sq).

Open Circuit A-C:	0.614	Short Circuit D-C:	0.025
Short Circuit A-C:	0.038	X/R Ratio:	9.522
Stator Slots:	60	Rotor Slots:	50

Speed Torque Current Curve (First Connection, First Speed)

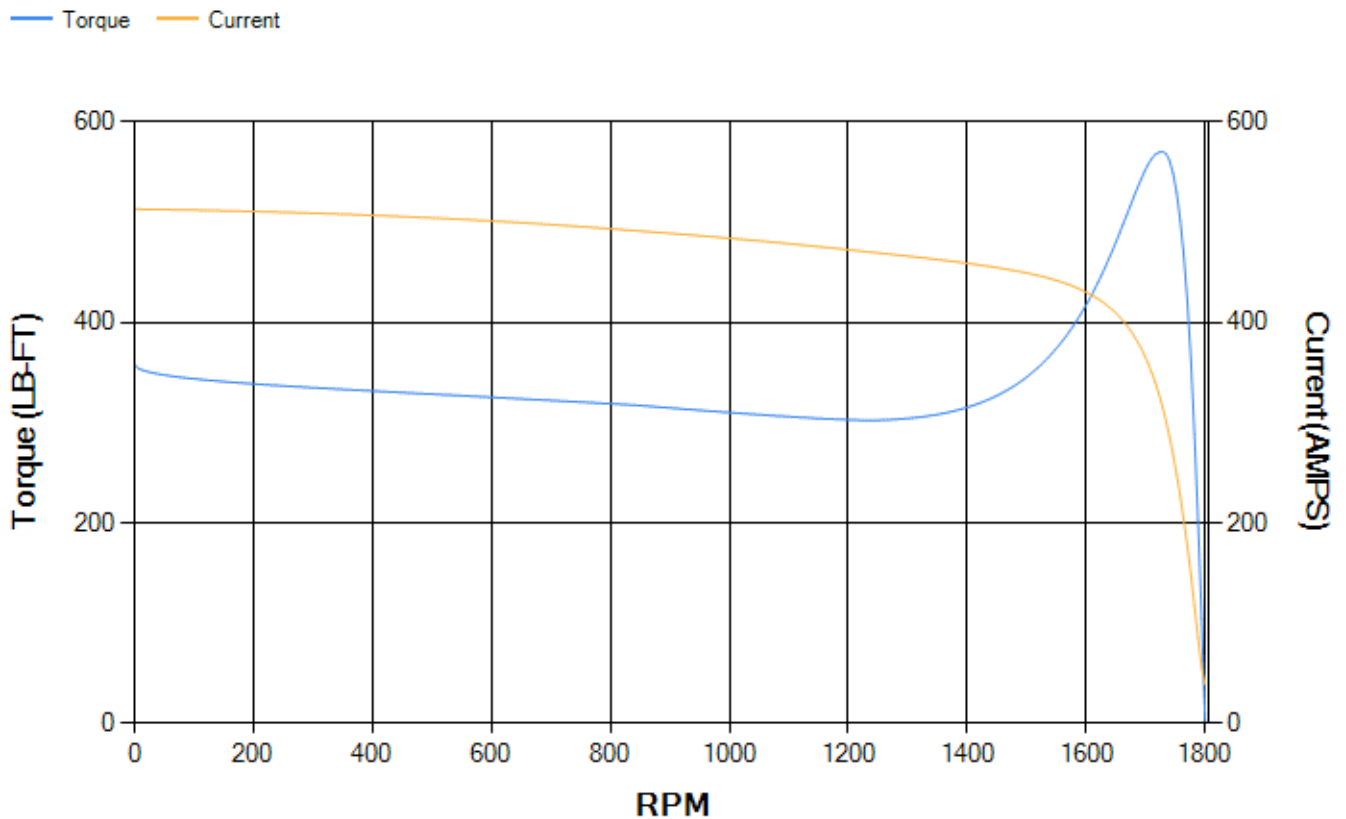

Marks:

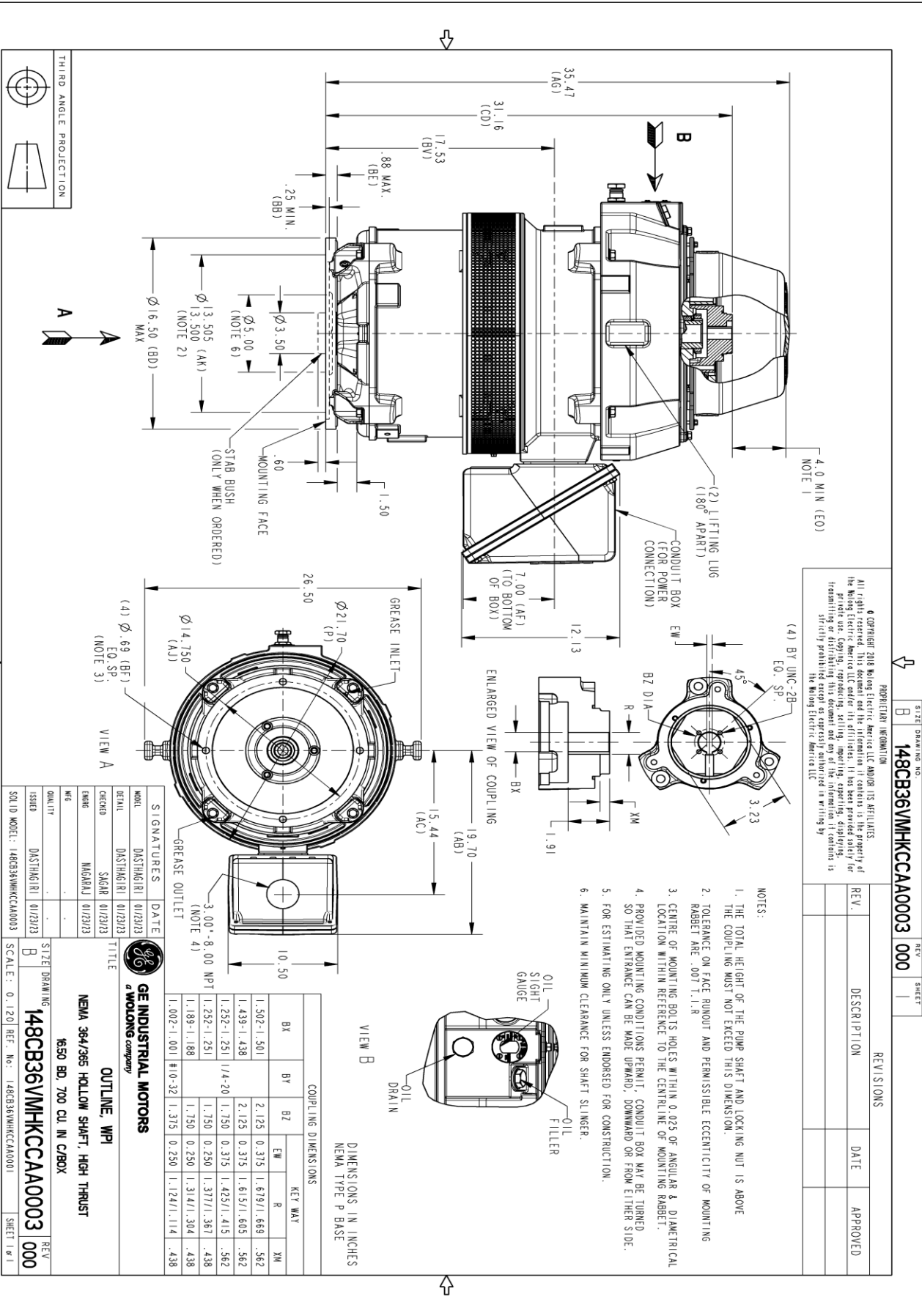

Marks:

Connection Diagram
GEM2034E-FIG9



Heater Connection
3027JE-1C

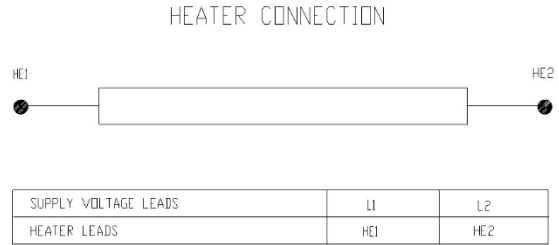

End shield Assembly		
Part Description	DE Side Part#	ODE Side Part#
End Shield	115E7255AA1	115E7259LK-G01
Bearing	235A2509BE01	235A2523AD01
Slinger/Inproseal	235A2300FM1	

Fan & Fan Cover Assembly	
Part Description	Part#
Fan	
Fan Cover	161C1053AA1

Conduit & Accessories Box Assembly	
Part Description	Part#
Conduit Box	118D4408AD2

Mechanical Accessories	
Part Description	Part#
Brake	
Tachometer	

