



GE INDUSTRIAL MOTORS
a **WOLONG** company

Product Technical Information

February 17, 2023

Data shown is for the current revision model #. Ensure your nameplate model # matches.

Model Number:	5KS444DAJ6095
Catalog Number:	V4480
Instruction Manual:	GEI-M1045
Connection Diagram:	GEM2034E-FIG273
Outline Drawing:	148CB44VMJKCCAA0001

Accessory Connection Diagrams

Bearing Thermocouple:	None	Heater:	3027JE-1C
RTD:	None	Thermistor:	None
Thermostat:	None	Winding Thermocouple:	None
Bearing RTD:	None		

Table of Contents

Specification	01
Performance Characteristics	02
Outline Drawing	03
Connection Drawing(s)	04
Spare parts	05

Marks:

MODEL NUMBER:	5KS444DAJ6095	Estimated Weight:	2490 Lbs
Outline Drawing:	148CB44VMJKCCAA0001	Time Rating:	CONT
Connection Diagram:	GEM2034E-FIG273	Enclosure:	WPI
Instruction Book:	GEI-M1045	Encl Construction:	OPEN
Design Code:	44BD1342A	Ambient Max(°C):	40
Type:	KS	Alt Ambient Max(°C):	--
Frame:	L444TP20	Insulation Class:	H
Phases:	3	NEMA Design:	B
Poles:	4	Nominal Efficiency:	95.8 %
Output Power:	200HP 148KW	Guaranteed Efficiency:	95.0 %
RPM:	1780	3/4 Load Efficiency:	--
Voltage:	460/575	KVA Code:	G
Hertz:	60	Max KVAR:	45.8
Amps - FL:	225.0/194.0	Power Factor:	87.5
Service Factor:	1.15	Bearing - DE:	6217C3
Alt Service Factor:	--	Bearing - ODE:	235A2536AB01

Enclosure is Weather Protected One

Stamped Nameplate Notes:

NEMA ENCLOSURE WP-I, CSA ENCL DP
 HTR LDS HE1-HE2 115V 145W
 ROT CCW FACING ODE LEAD/PH SEQ 1-2-3/1-2-3
 INVERTER DUTY PER NEMA MG1 PART 31
 ALTERNATE RATING FOR PWM CONTROL:1.0SF 40C AMBIENT
 VAR TORQUE RANGE 5-60 HZ
 UPPER BRG LUBE OIL: 10.2 QTS
 AMB 0 TO 40 DEG C : ISO 32(MINERAL OR SYNTHETIC)
 AMB -15 TO 0 DEG C : ISO 32 SYNTHETIC
 SUITABLE FOR 150 HP, 380V, 50 HZ WITH
 275.0 AMPS AND 1470 RPM AT 1.00 SF



Additional Information:

4P, VERT HOLLOW SHAFT HIGH THRUST (2D)
C/BOX 700 CU IN - 3.00" NPT
OIL RESISTANT SLEEVING ON LEADS
115V HTR LDS TO MAIN CONDUIT BOX
BEARING LIFE 8760 HRS AT 22500 LB THRUST
BEARING LIFE 9630 HRS AT 22000 LB THRUST
CG:22.60 IN FROM P-BASE FACE, STAT DEF:= 0.004 IN
RCF: 2950 CPM
NON-REVERSE BALL CARRIER,
BOLTED COUPLING, BX = 1.501 IN, EW= 0.375 IN
FIRE PUMP MOTOR
ESTIMATED SOUND PRESSURE 83 DBA AT 1 METER



Performance Characteristics

1st Winding 1st Connection

Design: 44BD1342A

Marks:

LOAD %	125.0	115.0	100.0	75.0	50.0	25.0	0.0
% EFF	94.4	94.67	95.2	95.3	95.02	92.68	0.00
% PF	87.74	87.84	87.6	85.61	79.38	60.01	4.96
AMPS	282.51	258.87	224.47	172.07	124.08	84.14	63.8

TORQ(FL)#FT	590.26	TORQ(LR)%FL	160.39	TORQ(BD)%FL	223.88
AMPS(LR)	1174.1	PF AT START	0.33		

This motor is capable of two cold or one hot start with a maximum connected load inertia of 2536 Lb-Ft Sq (106.77 Kg-meter Sq)at 100% voltage, where the load torque varies with the square of the speed. Acceleration time with maximum inertia and the above load type is 24 seconds. Safe stall time at 100% voltage is 48 seconds cold, 28 seconds hot. Rotor inertia is 64.39 Lb-Ft Sq (2.71 Kg-meter Sq).

Open Circuit A-C:	0.797	Short Circuit D-C:	0.031
Short Circuit A-C:	0.039	X/R Ratio:	11.857
Stator Slots:	72	Rotor Slots:	58

Speed Torque Current Curve (First Connection, First Speed)

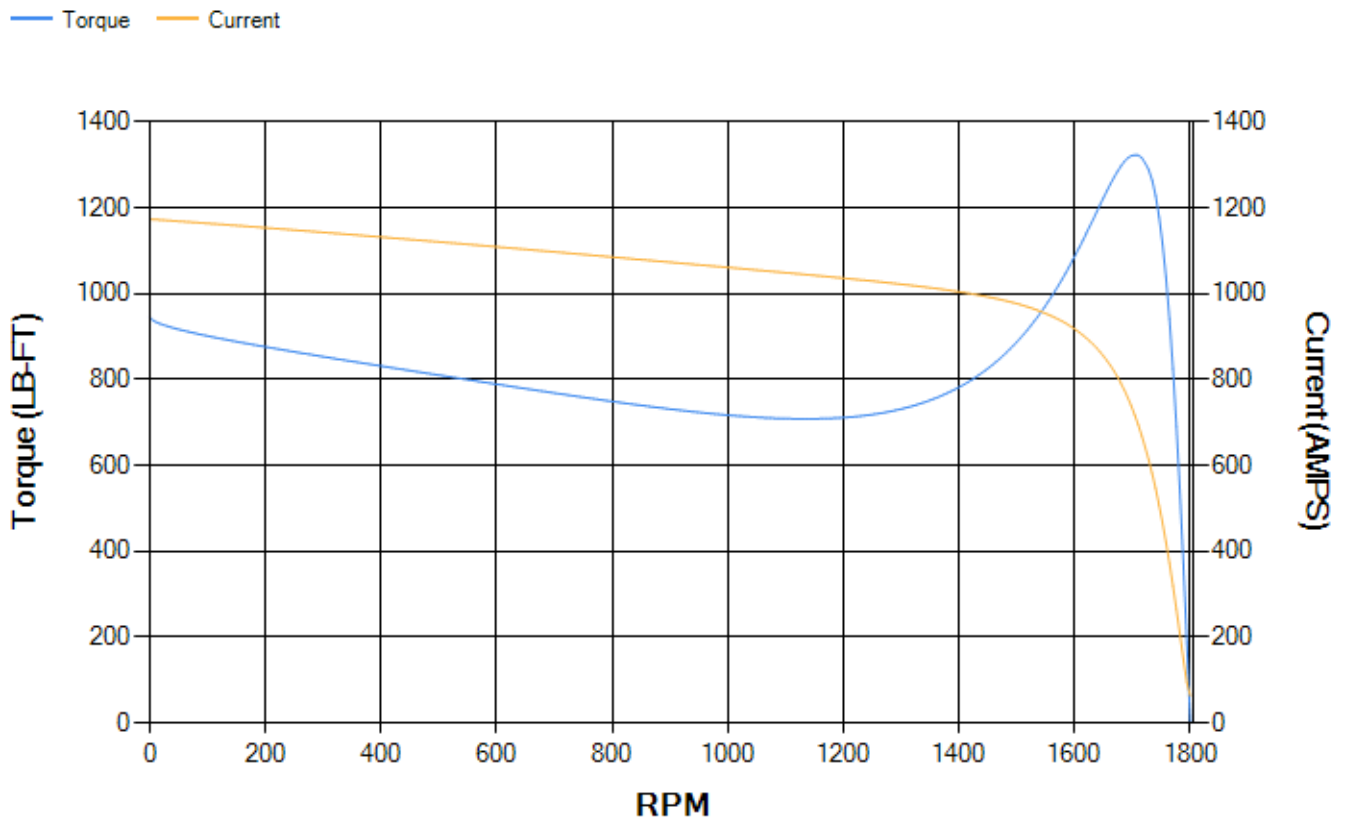

Marks:

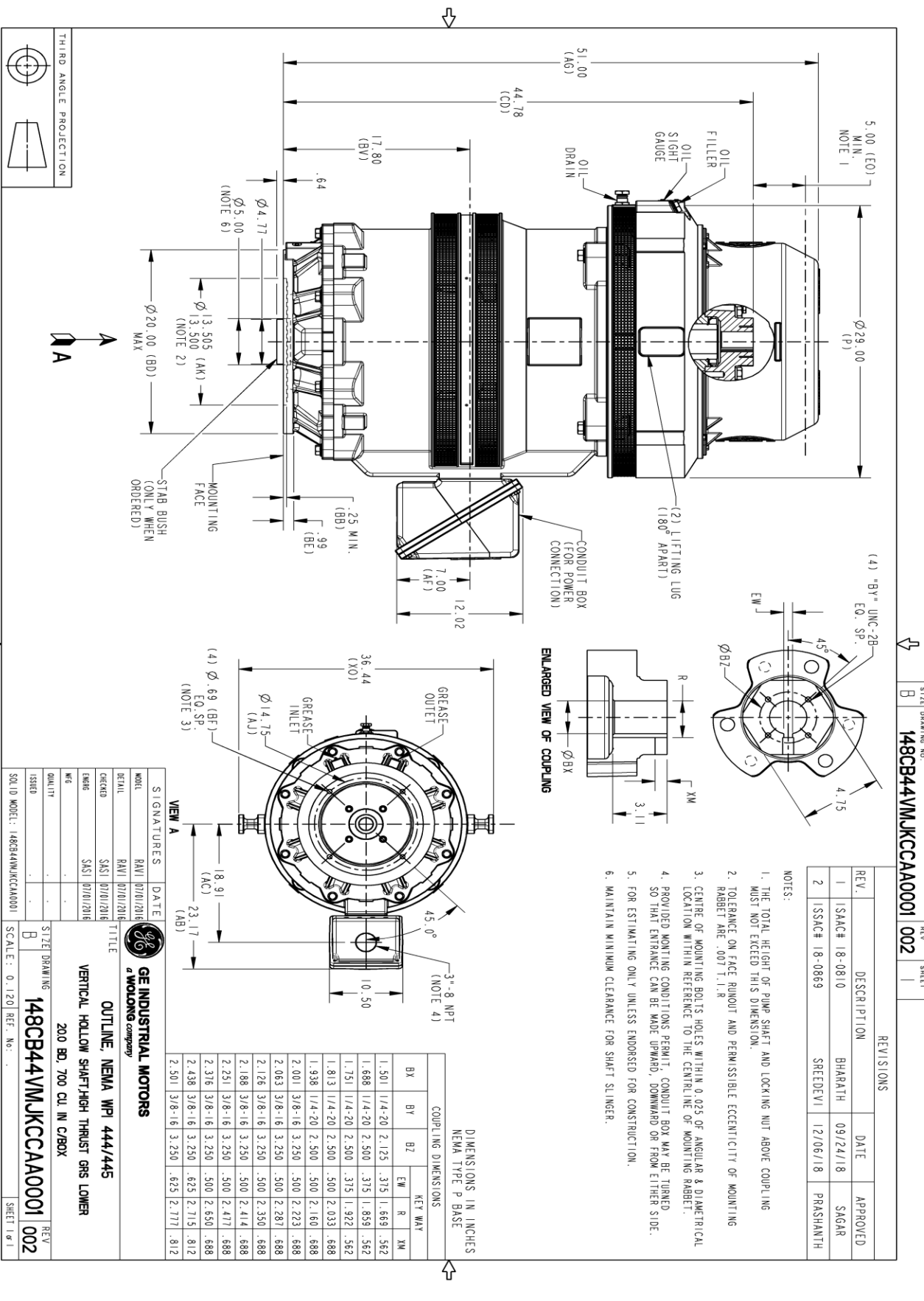

SIZE DRAWING NO. **B** REV. **002** SHEET **1**
148CB44VMJKCCA0001

SIGNATURES	DATE	TITLE
RAVI	07/01/2016	DESIGNER
SASI	07/01/2016	DRAWN
SASI	07/01/2016	CHECKED
ENG	07/01/2016	ISSUED
QUALITY		
SOLID MODEL: 148CB44VMJKCCA0001		
SCALE: 0.120	REF. NO.:	
GE INDUSTRIAL MOTORS a wolong company		
OUTLINE, NEMA WPI 444/445 VERTICAL HOLLOW SHAFT-HIGH THRUST GRS LOWER 200 BD, 700 CU. IN. C/B-BOX		
SIZE DRAWING 148CB44VMJKCCA0001 REV. 002 SHEET 1 OF 1		

Marks:

Connection Diagram
GEM2034E-FIG273

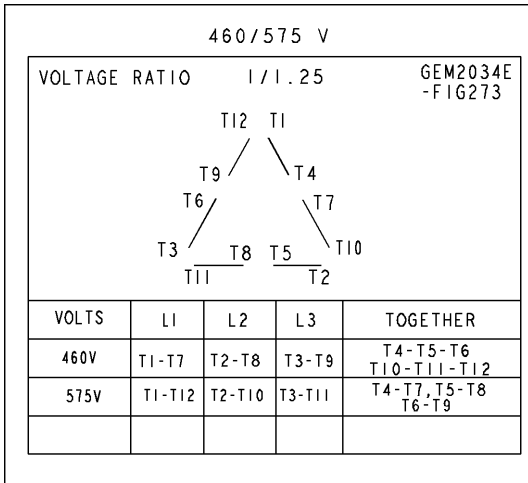

Heater Connection
3027JE-1C

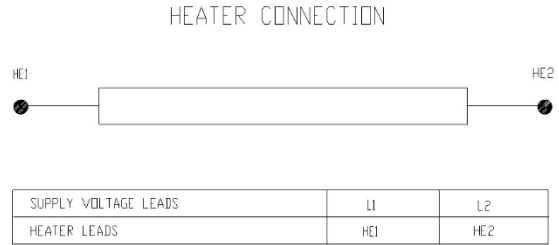

End shield Assembly		
Part Description	DE Side Part#	ODE Side Part#
End Shield	115E7661AA1	115E7670LM1
Bearing	235A2622AA01	235A2536AB01
Slinger/Inproseal	149C4399G06	

Fan & Fan Cover Assembly	
Part Description	Part#
Fan	
Fan Cover	161C1050AA1

Conduit & Accessories Box Assembly	
Part Description	Part#
Conduit Box	118D4408AD2

Mechanical Accessories	
Part Description	Part#
Brake	
Tachometer	

