



GE INDUSTRIAL MOTORS
a **WOLONG** company

Product Technical Information

July 15, 2020

Data shown is for the current revision model #. Ensure your nameplate model # matches.

Model Number:	5KS447DAJ6021D
Catalog Number:	V4530
Instruction Manual:	GEI-M1045
Connection Diagram:	GEM2034E-FIG19
Outline Drawing:	148CB49VMJKLGLA0001

Accessory Connection Diagrams

Bearing Thermocouple:	None	Heater:	3027JE-1C
RTD:	None	Thermistor:	None
Thermostat:	3027JE-2A	Winding Thermocouple:	None
Bearing RTD:	None		

Table of Contents

Specification	01
Performance Characteristics	02
Outline Drawing	03
Connection Drawing(s)	04
Spare parts	05

Marks:

MODEL NUMBER:	5KS447DAJ6021D	Estimated Weight:	2870 Lbs
Outline Drawing:	148CB49VMJKLGLA0001	Time Rating:	CONT
Connection Diagram:	GEM2034E-FIG19	Enclosure:	WPI
Instruction Book:	GEI-M1045	Encl Construction:	OPEN
Design Code:	49BD1381AB	Ambient Max(°C):	40
Type:	KS	Alt Ambient Max(°C):	--
Frame:	L447TP20	Insulation Class:	H
Phases:	3	NEMA Design:	B
Poles:	4	Nominal Efficiency:	95.8 %
Output Power:	300HP 222KW	Guaranteed Efficiency:	95.0 %
RPM:	1785	3/4 Load Efficiency:	--
Voltage:	460	KVA Code:	G
Hertz:	60	Max KVAR:	79.7
Amps - FL:	338.0	Power Factor:	87.0
Service Factor:	1.15	Bearing - DE:	6217C3
Alt Service Factor:	--	Bearing - ODE:	235A2536AB01

Enclosure is Weather Protected One

Stamped Nameplate Notes:

NEMA ENCLOSURE WP-I, CSA ENCL DP
 HTR LDS HE1-HE2 115V 145W
 ROT CCW FACING ODE LEAD/PH SEQ 1-2-3/1-2-3
 THERMOSTAT LEADS TB1-TB2 TRIP
 INVERTER DUTY PER NEMA MG1 PART 31
 ALTERNATE RATING FOR PWM CONTROL:1.0SF 40C AMBIENT
 VAR TORQUE RANGE 5 -60 HZ
 UPPER BRG LUBE OIL: 10.2 QTS
 0 DEG C TO 40 DEG C : ISO 32(MINERAL OR SYNTHETIC)
 -15 DEG C TO 0 DEG C : ISO 32 SYNTHETIC
 SUITABLE FOR 250 HP, 380V, 50 HZ WITH
 341.0 AMPS AND 1485 RPM AT 1.0 SF



Additional Information:

4P, VERT HOLLOW SHAFT HIGH THRUST (2D)
C/BOX 1260 CU IN - 2(4.00" NPT)
C/B GRD PLATE
SLINGER DE
OIL RESISTANT SLEEVING ON LEADS
(3)N.C. CL.F. TRIP TSTAT LDS TO MAIN CONDUIT BOX
115V HTR LDS TO MAIN CONDUIT BOX
GROUND PAD
INSULATED LOWER HALF COUPLING AT UPPER END
SHAFT GROUNDING RING MOUNTED ON LOWER END BRG CAP
BEARING LIFE 8760 HRS AT 22270 LB THRUST
PART WINDING START
CG:25.10 IN FROM P-BASE FACE,STAT DEF:= 0.005 IN
RCF: 2690 CPM
NON-REVERSE BALL CARRIER,
BOLTED COUPLING, BX = 1.688", EW = .375"



Performance Characteristics

1st Winding 1st Connection

Design: 49BD1381AB

Marks:

LOAD %	125.0	115.0	100.0	75.0	50.0	25.0	0.0
% EFF	94.83	95.03	95.46	95.4	94.95	92.32	0.00
% PF	88.15	87.89	87.08	83.98	76.1	54.88	4.59
AMPS	419.84	386.61	337.77	262.82	194.3	138.55	111.23

TORQ(FL)#FT	883.19	TORQ(LR)%FL	208.53	TORQ(BD)%FL	282.56
AMPS(LR)	2154.3	PF AT START	0.34		

This motor is capable of two cold or one hot start with a maximum connected load inertia of 4443 Lb-Ft Sq (187.05 Kg-meter Sq)at 100% voltage, where the load torque varies with the square of the speed. Acceleration time with maximum inertia and the above load type is 21 seconds. Safe stall time at 100% voltage is 38 seconds cold, 25 seconds hot. Rotor inertia is 91.5 Lb-Ft Sq (3.85 Kg-meter Sq).

Open Circuit A-C:	0.849	Short Circuit D-C:	0.03
Short Circuit A-C:	0.038	X/R Ratio:	11.463
Stator Slots:	72	Rotor Slots:	58

Speed Torque Current Curve (First Connection, First Speed)

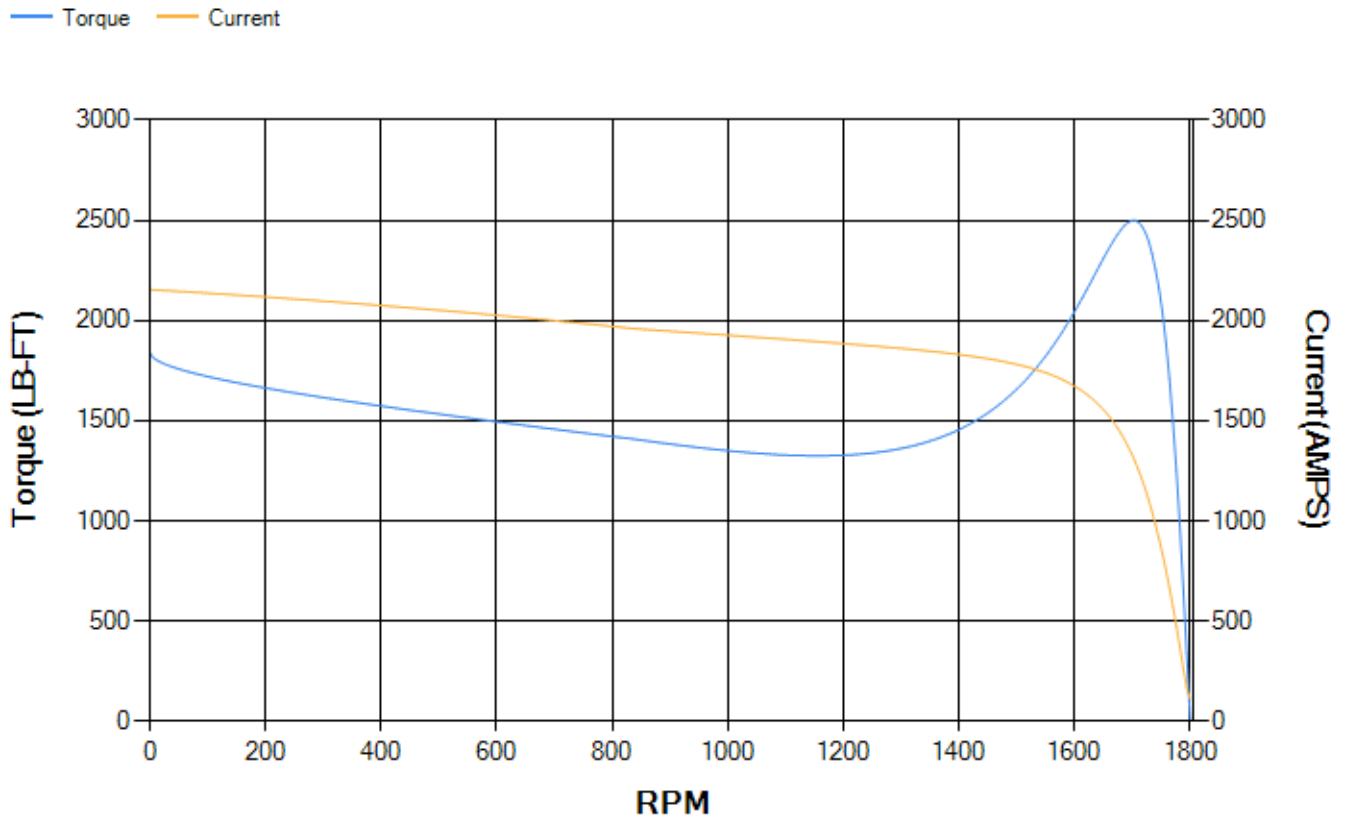

Marks:

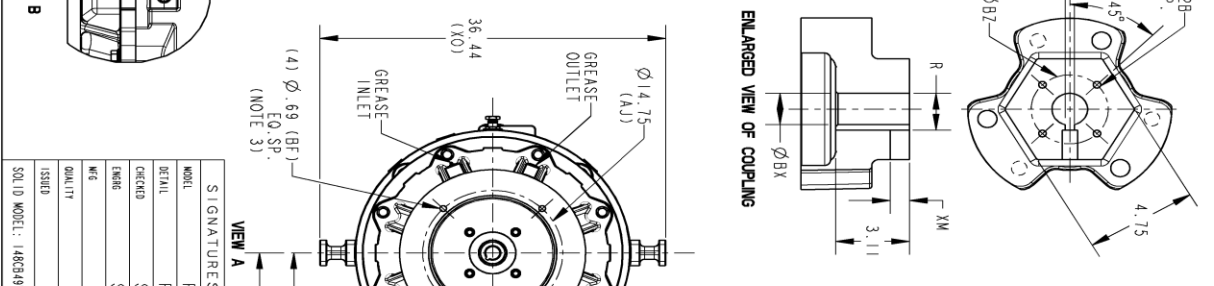
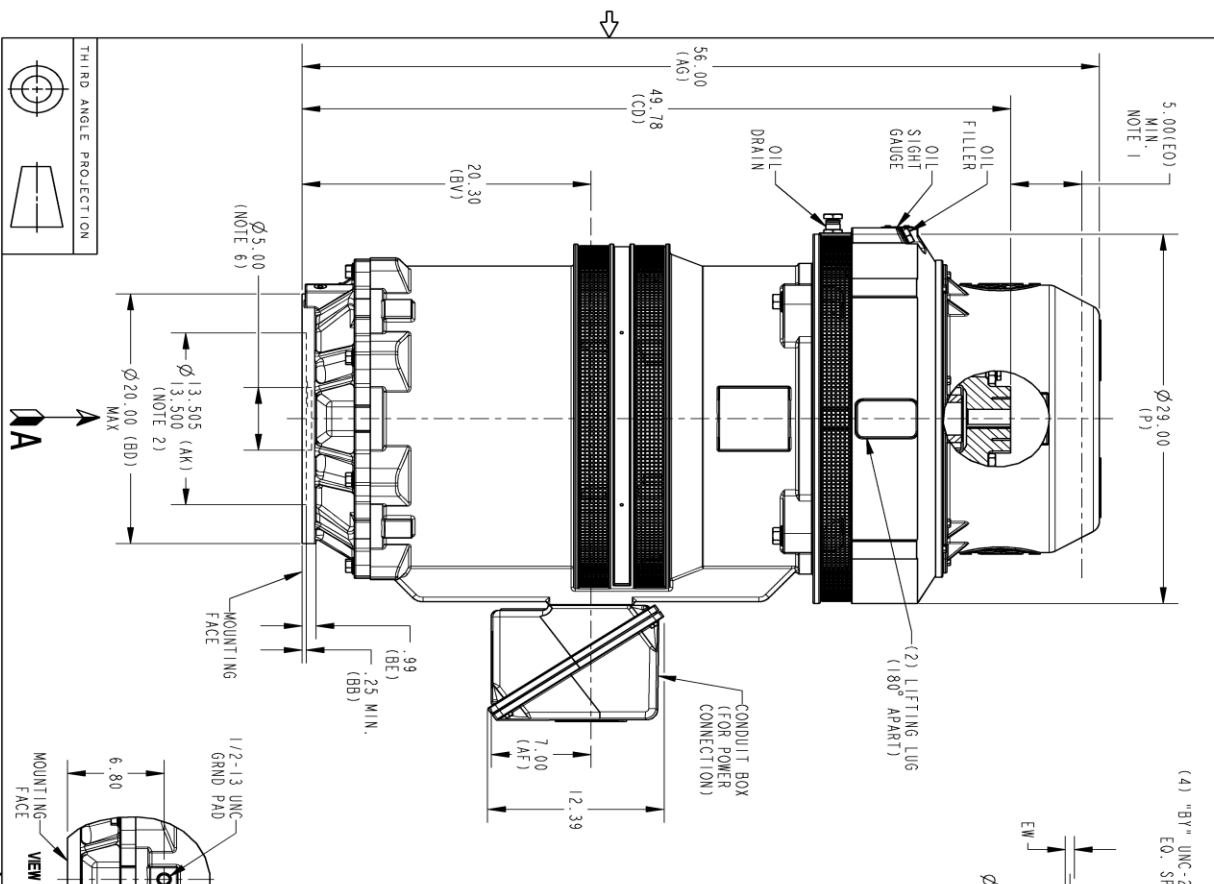

REV.	DESCRIPTION	DATE	APPROVED
1	ISAC# 16-0728	07/21/16	SASI
2	ISSAC# 18-0869	12/11/18	PRASHANTH
3	ISAC# 19-0869	11/29/19	HARIKIRAN

SIGNATURES	DATE
RAVI	06/30/16
SASI	06/30/16
SASI	06/30/16
ISSID	

DETAIL	DATE
RAVI	06/30/16
SASI	06/30/16

KEY WAY	BX	BY	BZ	EW	R	XW
	1.501	1/4-20	2.125	.315	1.669	.662
	1.688	1/4-20	2.500	.375	1.859	.662
	1.751	1/4-20	2.500	.315	1.922	.662
	1.813	1/4-20	2.500	.500	2.033	.668
	1.938	1/4-20	2.500	.500	2.160	.668
	2.001	3/8-16	3.250	.500	2.223	.668
	2.063	3/8-16	3.250	.500	2.287	.668
	2.126	3/8-16	3.250	.500	2.350	.668
	2.188	3/8-16	3.250	.500	2.414	.668
	2.251	3/8-16	3.250	.500	2.477	.668
	2.316	3/8-16	3.250	.500	2.541	.668
	2.438	3/8-16	3.250	.625	2.715	.812
	2.501	3/8-16	3.250	.625	2.778	.812

NOTES:

1. THE TOTAL HEIGHT OF PUMP SHAFT AND LOCKING NUT ABOVE COUPLING MUST NOT EXCEED THIS DIMENSION.
2. TOLERANCE ON FACE RINDOUT AND PERMISSIBLE ECCENTRICITY OF MOUNTING RABBIT ARE .007 T. I. R
3. CENTRE OF MOUNTING BOLTS WITHIN 0.025 OF ANGULAR & DIAMETRICAL LOCATION WITHIN REFERENCE TO THE CENTRLINE OF MOUNTING RABBIT.
4. PROVIDED MONTING CONDITIONS PERMIT, CONDUIT BOX MAY BE TURNED SO THAT ENTRANCE CAN BE MADE UPWARD, DOWNWARD OR FROM EITHER SIDE.
5. FOR ESTIMATING ONLY UNLESS ENDORSED FOR CONSTRUCTION.
6. MAINTAIN MINIMUM CLEARANCE FOR SHAFT SLINGER.

GE INDUSTRIAL MOTORS
 GE WOLONG COMPANY

OUTLINE, NEMA WP1 447-449
VERTICAL HOLLOW SHAFT-HIGH THRUST GRS LOWER
 200 BD, 1260 CU IN C/BOX GRND PAID

SIZE: 148CB49VMJKLGLA0001
 SCALE: 0.120 REF. NO. 003

REV. 1

SIZE DRAWING NO. 148CB49VMJKLGLA0001 003
 REV. SHEET 1

Marks:

Connection Diagram
GEM2034E-FIG19



Heater Connection
3027JE-1C



Thermostat Connection
3027JE-2A

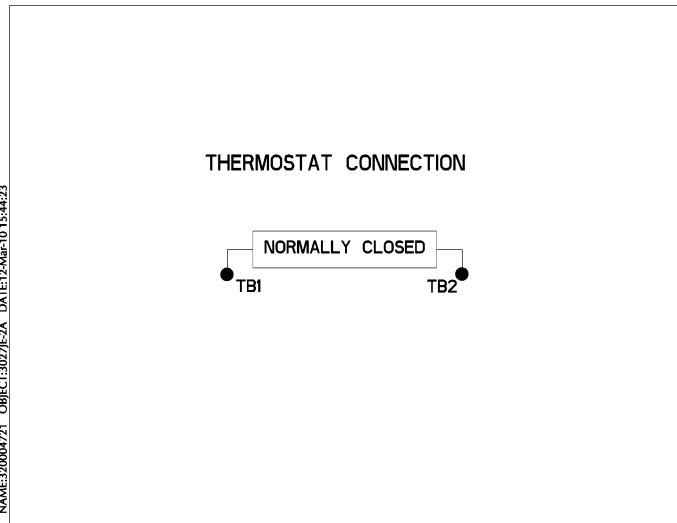

End shield Assembly		
Part Description	DE Side Part#	ODE Side Part#
End Shield	115E7661AA1	115E7670LM1
Bearing	235A2522AJ01	235A2536AB01
Slinger/Inproseal	149C4399G06	

Fan & Fan Cover Assembly	
Part Description	Part#
Fan	
Fan Cover	161C1050AA1

Conduit & Accessories Box Assembly	
Part Description	Part#
Conduit Box	179B9058G03

Mechanical Accessories	
Part Description	Part#
Brake	
Tachometer	

