

BALDOR® • RELIANCE 

Product Information Packet

VDRX28344T

30HP,1770//1470RPM,3PH,60/50HZ,286TC,XPF

Part Detail							
Revision:	F	Status:	PRD/A	Change #:		Proprietary:	No
Type:	AC	Elec. Spec:	10WGY538	CD Diagram:	CD0180	Mfg Plant:	
Mech. Spec:		Layout:	10LYG292	Poles:	04	Created Date:	06-06-2019
Base:		Eff. Date:	01-12-2022	Leads:	9#8		

Specs			
Catalog Number:	VDRX28344T	Duty Rating:	CONT
Enclosure:	XPFC	Electrically Isolated Bearing:	Not Electrically Isolated
Frame:	286TC	Feedback Device:	NO FEEDBACK
Frame Material:	Iron	Heater Indicator:	No Heater
Output @ Frequency:	30.000 HP @ 60 HZ	Insulation Class:	F
	25.000 HP @ 50 HZ	Inverter Code:	Inverter Duty
Synchronous Speed @ Frequency:	1800 RPM @ 60 HZ	IP Rating:	NONE
Voltage @ Frequency:	190.0 V @ 50 HZ	KVA Code:	G
	230.0 V @ 60 HZ	Lifting Lugs:	Standard Lifting Lugs
	380.0 V @ 50 HZ	Locked Bearing Indicator:	Locked Bearing
	460.0 V @ 60 HZ	Motor Lead Termination:	Flying Leads
XP Class and Group:	CLI GP C,D	Motor Type:	1056M
XP Division:	Division I	Mounting Arrangement:	F1
Agency Approvals:	UR	Power Factor:	83
	CSA EEV	Product Family:	Hazardous Location Motor
	CSA	Pulley Face Code:	C-Face
Auxillary Box:	No Auxillary Box	Rodent Screen:	None
Auxillary Box Lead Termination:	None	RoHS Status:	ROHS NON-COMPLIANT

Base Indicator:	No Mounting	Shaft Ground Indicator:	No Shaft Grounding
Bearing Grease Type:	Polyrex EM (-20F +300F)	Shaft Rotation:	Reversible
Blower:	None	Speed Code:	Single Speed
Constant Torque Speed Range:	6	Motor Standards:	NEMA
Current @ Voltage:	76.000 A @ 208.0 V	Starting Method:	Direct on line
	74.000 A @ 190.0 V	Thermal Device - Bearing:	None
	72.000 A @ 230.0 V	Thermal Device - Winding:	Normally Closed Thermostat
	37.000 A @ 380.0 V	Vibration Sensor Indicator:	No Vibration Sensor
	36.000 A @ 460.0 V	Winding Thermal 1:	None
Design Code:	A	Winding Thermal 2:	None
Drip Cover:	No Drip Cover	XP Temp Code:	T3C

Nameplate NP1401XPSLEV												
NO.						CC	010A					
S/N						TEMP CODE	T3C					
SPEC.	10-0000-0851					INV.TYPE	PWM					
CAT.NO.	VDRX28344T					C HP FR	60		C HP TO	90		
HP	30//25					CT HZ FROM	6		CT HZ TO	60		
VOLTS	230/460//190/380					VT HZ FROM	6		VT HZ TO	60		
AMPS	76/38//76/38					MAG CUR	39.6/19.8					
RPM	1760//1475					MX RPM	2700					
HZ	60//50			PH	3		CL	F				
SER.F.	1.00			DES	A		SL HZ	1.3		NOM.EFF.	93.6	
FRAME	286TC			RATING	40C AMB-CONT		WK2	4.46				
55C AMB @ 1.0 SF, 60C RISE												
1.15SF ON SINEWAVE					NEMA MG-1 P5.5,IP55							

Parts List		
Part Number	Description	Quantity
SA370408	SA 10-0000-0851	1.000 EA
RA360058	RA 10-0000-0851	1.000 EA
LB1115N	LABEL,LIFTING DEVICE (ON ROLLS)	1.000 EA
LB1119N	WARNING LABEL	1.000 EA
LC0181	CONNECTION LABEL	1.000 EA
LB1417	LABEL CARTON 6X4 PERFORATED BLANK ROLLS	1.000 EA
NP1401XPSLEV	SS XP INV UL CSA-EEV CC CL-I GP-C&D	1.000 EA
85XU0407S04	4X1/4 U DRIVE PIN STAINLESS	2.000 EA
MN416A01	TAG-INSTAL-MAINT no wire (2100/bx) 4/22	1.000 EA
LB1081C	ALUM XP CAUTION LABEL (COL PLANT ONLY-	1.000 EA
10FH1008A01P	310 FAN HOUSING X-PROOF MACH. W/EPOXY PR	1.000 EA
HW1001A31	LOCKWASHER 5/16, ZINC PLT.591 OD, .319 I	3.000 EA
10XN3118K12	5/16-18 X .75 GRADE 5, ZINC PLATED	3.000 EA
09FN3001C02	EXTERNAL FAN, PLASTIC (COMES W/SCREW FRO	1.000 EA
HW2500A25	WOODRUFF KEY USA #1008 #BLOW CARBON STEE	1.000 EA
MJ1000A02	GREASE, MOBIL POLYREX EM - 124047	0.130 LB
WD4100A03	DE-750 HEYCO PLUG 62MP0750 MICRO PLASTIC	1.000 EA
10EP1701A57LP5	FR ENDPLATE, MACH PRIMED & PAINTED	1.000 EA
HA3050A03	3/8-16 X 2.25" GRADE 8 BOLT	4.000 EA
HW1001A38	LOCKWASHER 3/8, ZINC PLT .688 OD, .382 I	4.000 EA
HA2066A02	SLINGER, ALUM (AUTO)	1.000 EA
80XN1032A06	10-32 X 3/8 SET SC HEX SOCK	2.000 EA
HW5100A11	W3917-042 WVY WSHR (WB)	1.000 EA
HA4051A00	PLASTIC CAP FOR GREASE FITTING	1.000 EA

Parts List (continued)		
Part Number	Description	Quantity
HW4500A21	1618BALEMITE FITTING 825 UNIVERSAL	1.000 EA
HW4500A17	317400 ALEMITE GREASE RELIEF	1.000 EA
HW4505A02	BREATHER/DRAIN-EXP PROOF-.250-18 PTF AIS	1.000 EA
HW3023E06	.125 X .625 SPIRAL SPRING PIN	1.000 EA
10EP1710A09P	FACE MTD. EP MACH XPFC W/HW4505A02 W/PRI	1.000 EA
HW1001A38	LOCKWASHER 3/8, ZINC PLT .688 OD, .382 I	4.000 EA
HA3050A03	3/8-16 X 2.25" GRADE 8 BOLT	4.000 EA
HA2067A01	ALUM SLINGER (AUTO)	1.000 EA
80XN1032A06	10-32 X 3/8 SET SC HEX SOCK	2.000 EA
10XN2520K40	1/4-20 X 2-1/2 HEX HD CAPSCREW, GRADE 5,Z	4.000 EA
HW1001A25	LOCKWASHER 1/4, ZINC PLT .493 OD, .255 I	4.000 EA
HA4051A00	PLASTIC CAP FOR GREASE FITTING	1.000 EA
HW4500A03	GREASE FITTING, .125 NPT 1610(ALEMITE) 8	1.000 EA
HW4500A17	317400 ALEMITE GREASE RELIEF	1.000 EA
HW4505A02	BREATHER/DRAIN-EXP PROOF-.250-18 PTF AIS	1.000 EA
HW3023E06	.125 X .625 SPIRAL SPRING PIN	1.000 EA
12CB1003A02P	KOBX, MACH 1.50 NPT GROUP C MTRS ,EPOXY	1.000 EA
10XN3118K24	5/16-18 X 1.50" HEX HD, GRADE 5	4.000 EA
HW1001A31	LOCKWASHER 5/16, ZINC PLT.591 OD, .319 I	4.000 EA
WD1000B19	TERMINAL BURNDY L250HP	1.000 EA
10XN3816K12	3/8-16 X 3/4 HEX HD CAP GRADE 5	1.000 EA
HW1001A38	LOCKWASHER 3/8, ZINC PLT .688 OD, .382 I	1.000 EA
12CB1502A01P	CONDUIT BOX LID MACH. GROUP C MTRS	1.000 EA
84XN5013J32	SOCKET HD.CAP SCR,1/2-13 X 2"LG,ALLOY ST	10.000 EA

Product Information Packet: VDRX28344T - 30HP,1770//1470RPM,3PH,60/50HZ,286TC,XPF

HW1001A50	LOCKWASHER 1/2, ZINC PLT, .879 OD, .509 I	10.000 EA
MG1025G29	WILKOFAS, 789.229, DARK CHARCOAL GRAY	0.125 GA
PK6014	STEEL STRAP FOR 309-312 BASELESS MOTORS	4.000 EA
10PA1051	PKGP CRATE 310 VERT 32X30-1/2X17-1/2 RIS	1.000 EA
10XN3816K10	BOLT, 3/8-16 X 5/8 HHCS YZ	4.000 EA
HW2501H28	KEY, 1/2 SQ X 3.250	1.000 EA

AC Induction Motor Performance Data

Record # 83882

Typical performance - not guaranteed values

Winding: 10WGY538-R047		Type: 1056M		Enclosure: XPFC	
Nameplate Data			460 V, 60 Hz: High Voltage Connection		
Rated Output (HP)	30//25		Full Load Torque	88.7 LB-FT	
Volts	230/460//190/380		Start Configuration	direct on line	
Full Load Amps	76/38		Breakdown Torque	330 LB-FT	
R.P.M.	1760//1475		Pull-up Torque	142 LB-FT	
Hz	60 Phase	3	Locked-rotor Torque	178 LB-FT	
NEMA Design Code	A	KVA Code	J	Starting Current	270 A
Service Factor (S.F.)			1	No-load Current	17.9 A
NEMA Nom. Eff.	93.6	Power Factor	80	Line-line Res. @ 25°C	0.19377 Ω
Rating - Duty	40C AMB-CONT			Temp. Rise @ Rated Load	64°C
				Locked-rotor Power Factor	30.9
				Rotor inertia	4.47 lb-ft ²

Load Characteristics 460 V, 60 Hz, 30 HP

% of Rated Load	25	50	75	100	125	150
Power Factor	41	63	73	80	82	85
Efficiency	87.6	92.3	93.5	93.7	93.4	92.9
Speed	1792.2	1787.6	1782.4	1776.5	1770.3	1762.1
Line amperes	19.8	24.3	30.7	37.6	45.6	55.2

Performance Graph at 460V, 60Hz, 30.0HP Typical performance - Not guaranteed values

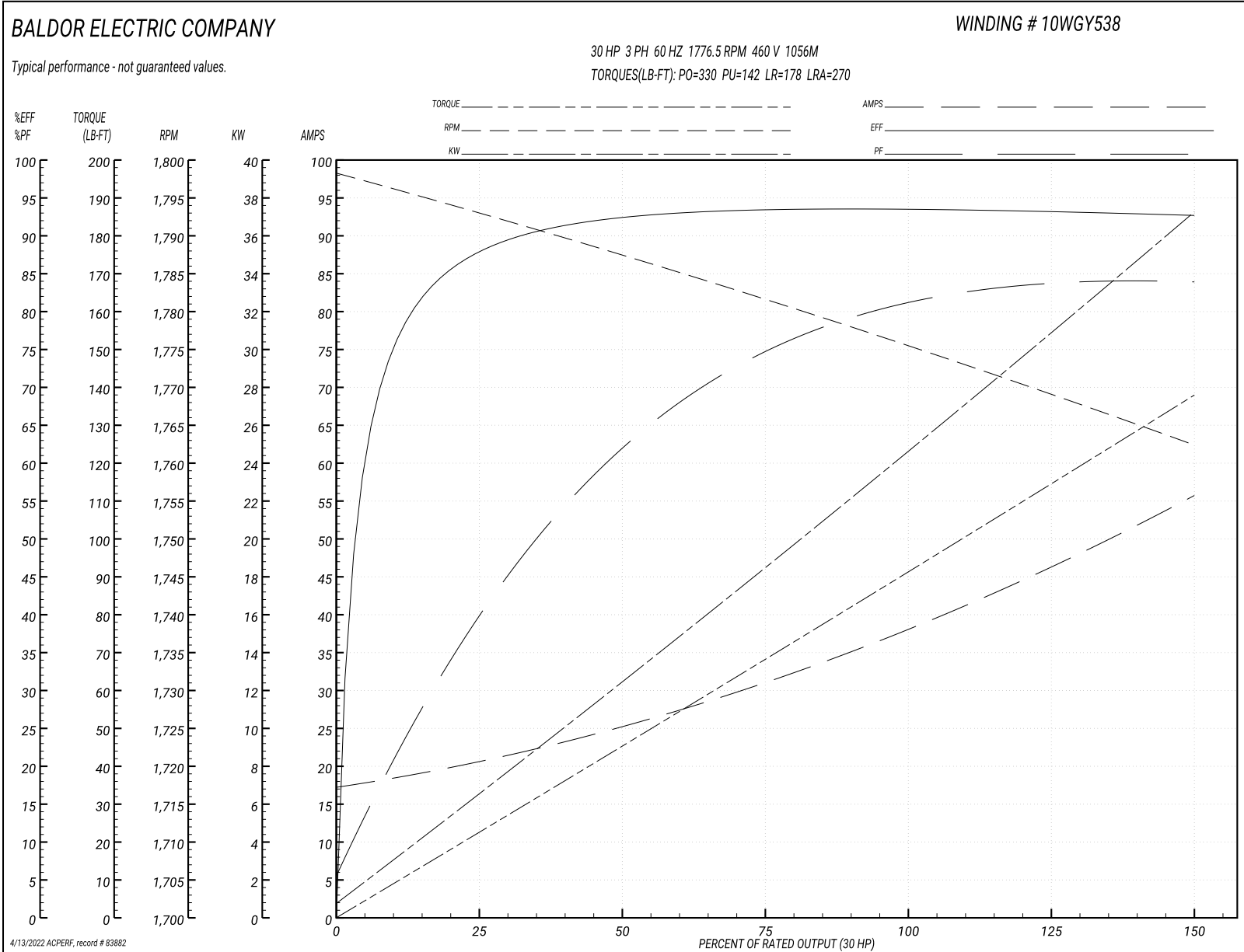

AC Induction Motor Performance Data

Record # 83883

Typical performance - not guaranteed values

Winding: 35WGM218-R026			Type: 3516M			Enclosure: TEFC				
Nameplate Data						575 V, 60 Hz: Single Voltage Motor				
Rated Output (HP)	.75		Full Load Torque			2.22 LB-FT				
Volts	575		Start Configuration			direct on line				
Full Load Amps	.9		Breakdown Torque			10.6 LB-FT				
R.P.M.	1750		Pull-up Torque			6.34 LB-FT				
Hz	60	Phase	3	Locked-rotor Torque			7.57 LB-FT			
NEMA Design Code	B		KVA Code	M		Starting Current			7.89 A	
Service Factor (S.F.)	1.25		No-load Current			0.621 A				
NEMA Nom. Eff.	84	Power Factor	71	Line-line Res. @ 25°C			34.7 Ω			
Rating - Duty	40C		AMB-CONT		Temp. Rise @ Rated Load			30°C		
S.F. Amps	1.1		Temp. Rise @ S.F. Load			38°C				
						Locked-rotor Power Factor			65.1	
						Rotor inertia			0.0946 lb-ft ²	

Load Characteristics 575 V, 60 Hz, 0.75 HP

% of Rated Load	25	50	75	100	125	150	S.F.
Power Factor	31	48	62	71	78	83	78
Efficiency	68.4	80	83.4	84.4	84.3	82.1	84.3
Speed	1790	1778	1766	1753	1739	1722	1739
Line amperes	0.647	0.711	0.808	0.924	1.07	1.24	1.07

Performance Graph at 575V, 60Hz, 0.75HP Typical performance - Not guaranteed values

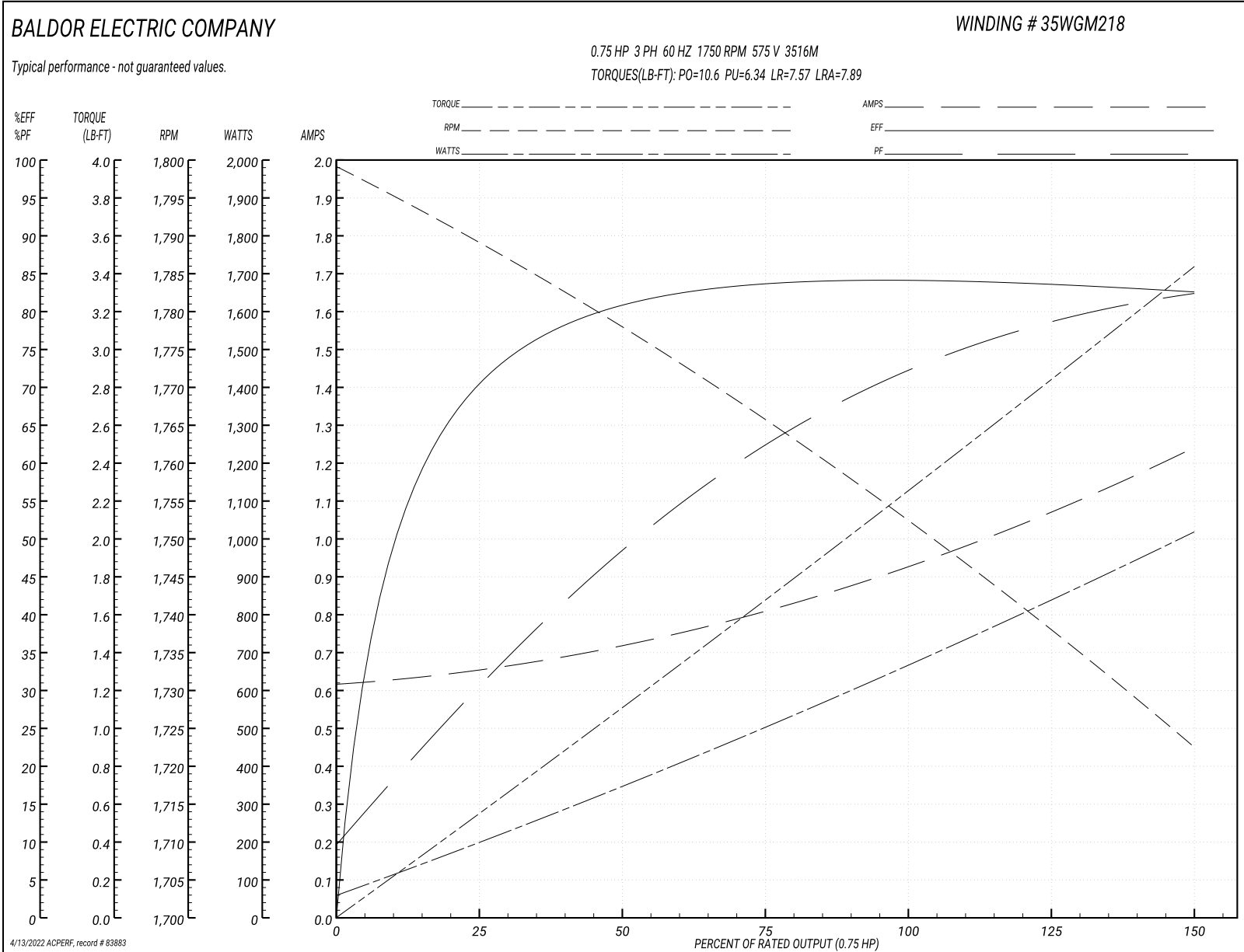

10LYG292

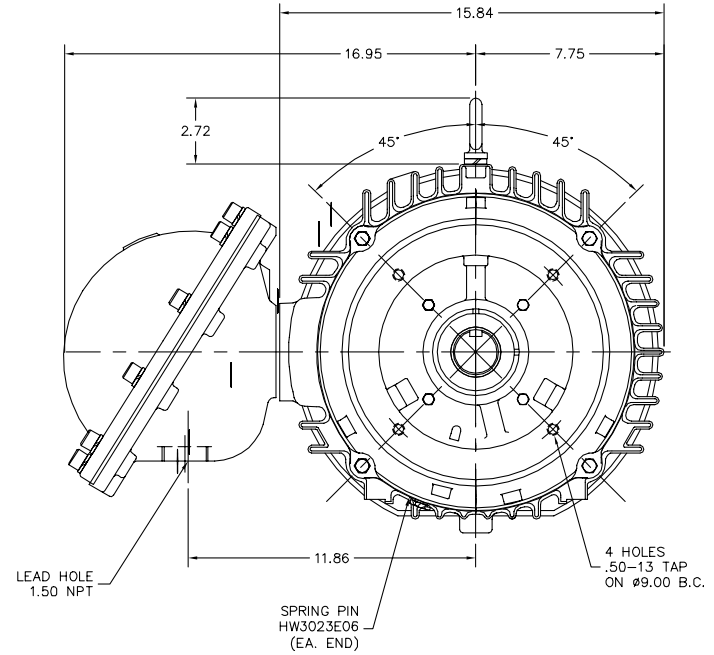
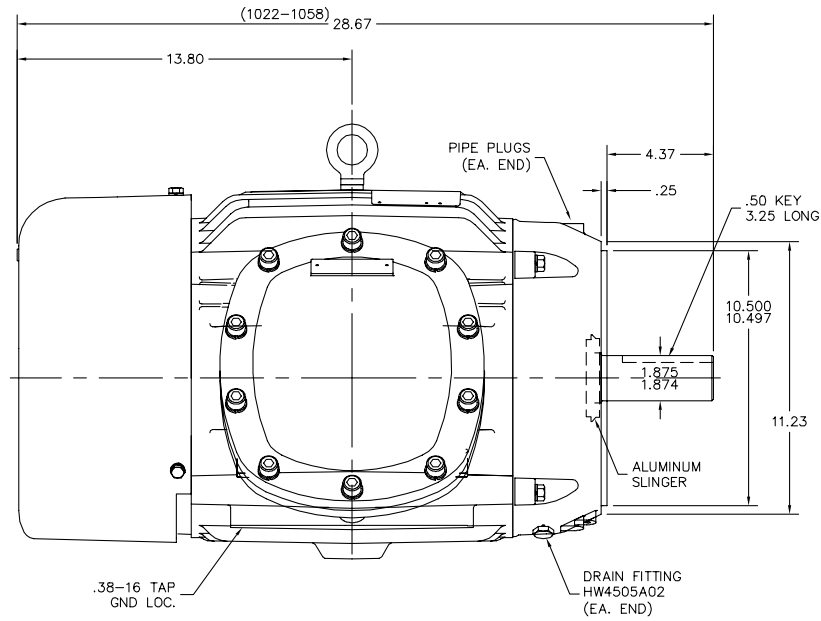

10LYG292

CUSTOMER IS RESPONSIBLE FOR DETERMINING THAT BALDOR'S PRODUCT WILL PERFORM SUITABLY IN THE INTENDED APPLICATION.

REV. DESC: ADDED GND HOLE TAP SIZE	VERSION: 05	TDR: 000000954909
REV. LTR: E	REVISED: 03:14:34 12/07/2015	BY: ENNINDO
FILE: \AAA\00137\778		
MTL: -		

BALDOR

VERT XPFC 284-6TC CL.I GP.C&D ONLY DRILL RIG
SH 1 of 1

CD0180

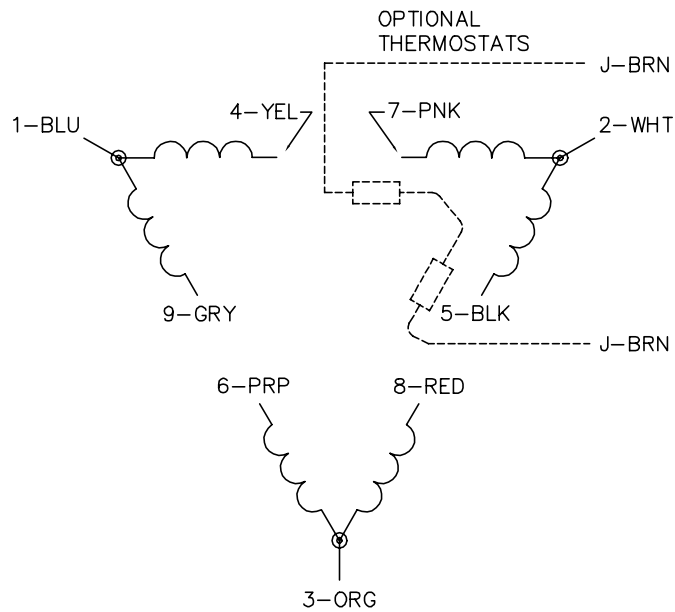

LOW VOLTAGE
(2D)

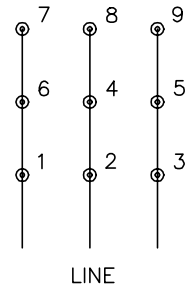

HIGH VOLTAGE
(1D)

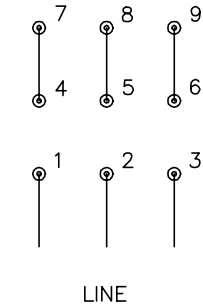

NOTES:

1. INTERCHANGE ANY TWO LINE LEADS TO REVERSE ROTATION.
2. OPTIONAL THERMOSTATS ARE PROVIDED WHEN SPECIFIED.
3. ACTUAL NUMBER OF INTERNAL PARALLEL CIRCUITS MAY BE A MULTIPLE OF THOSE SHOWN ABOVE.
4. LEAD COLORS ARE OPTIONAL. LEADS MUST ALWAYS BE NUMBERED AS SHOWN.

CD0180

REV. DESC: ADD CLASS CONN00000007		
REV. LTR: D	VERSION: 01	TDR: 000001099922
FILE: \AAA\00005\148	REVISED: 10:25:29 02/19/2019	BY: ENBRIRO
MTL: -	© □	

BALDOR - RELIANCE®

3PH, DV, 9 LEADS, DELTA CONNECTION

SH 1 of 1

Marketing maintained PDF of MN416:

<http://www.baldor.com/support/Literature/Load.ashx/MN416?ManNumber=MN416>