

BALDOR® • RELIANCE 

Product Information Packet

VEJMM3313T

10HP,1770RPM,3PH,60HZ,215JM,3742M,ODP,F1

Part Detail							
Revision:	L	Status:	PRD/A	Change #:		Proprietary:	No
Type:	AC	Elec. Spec:	37WGT853	CD Diagram:	CD0005	Mfg Plant:	
Mech. Spec:	37N905	Layout:	37LYN905	Poles:	04	Created Date:	07-18-2016
Base:	N	Eff. Date:	08-11-2021	Leads:	9#14		

Specs			
Catalog Number:	VEJMM3313T	Insulation Class:	F
Enclosure:	ODP	Inverter Code:	Inverter Ready
Frame:	215JM	KVA Code:	H
Frame Material:	Steel	Lifting Lugs:	Standard Lifting Lugs
Output @ Frequency:	10.000 HP @ 60 HZ	Locked Bearing Indicator:	Locked Bearing
Synchronous Speed @ Frequency:	1800 RPM @ 60 HZ	Motor Lead Quantity/Wire Size:	9 @ 14 AWG
Voltage @ Frequency:	460.0 V @ 60 HZ	Motor Lead Exit:	Ko Box
	230.0 V @ 60 HZ	Motor Lead Termination:	Flying Leads
XP Class and Group:	None	Motor Type:	3742M
XP Division:	Not Applicable	Mounting Arrangement:	F1
Agency Approvals:	UR	Power Factor:	82
	CSA EEV	Product Family:	General Purpose
	CSA	Pulley End Bearing Type:	Ball
Auxillary Box:	No Auxillary Box	Pulley Face Code:	C-Face
Auxillary Box Lead Termination:	None	Pulley Shaft Indicator:	Tapped & Key
Base Indicator:	No Mounting	Rodent Screen:	Included
Bearing Grease Type:	Polyrex EM (-20F +300F)	RoHS Status:	ROHS COMPLIANT
Blower:	None	Shaft Extension Location:	Pulley End

Current @ Voltage:	12.500 A @ 460.0 V	Shaft Ground Indicator:	No Shaft Grounding
	25.000 A @ 230.0 V	Shaft Rotation:	Reversible
	26.000 A @ 208.0 V	Shaft Slinger Indicator:	Shaft Slinger
Design Code:	B	Speed Code:	Single Speed
Drip Cover:	Drip Cover	Motor Standards:	NEMA
Duty Rating:	CONT	Starting Method:	Direct on line
Electrically Isolated Bearing:	Not Electrically Isolated	Thermal Device - Bearing:	None
Feedback Device:	NO FEEDBACK	Thermal Device - Winding:	None
Front Face Code:	Drip Cover Mounting	Vibration Sensor Indicator:	No Vibration Sensor
Front Shaft Indicator:	None	Winding Thermal 1:	None
Heater Indicator:	No Heater	Winding Thermal 2:	None

Nameplate NP3553LUA										
CAT.NO.	VEJMM3313T									
SPEC.	37N905T853G1									
HP	10									
VOLTS	230/460									
AMPS	25/12.5									
RPM	1770									
FRAME	215JM				HZ	60			PH	3
SF	1.15		CODE	H	DES	B		CLASS	F	
NEMA NOM. EFF	91.7		PF	82						
RATING	40C AMB-CONT									
CC	010A				USABLE AT 208V					26
DE	6309				ODE	6206				
ENCL	ODP		SN							
VPWM INVERTER READY										
CT30-60(2:1) VT3-60(20:1)										
USABLE AT	50HZ 7.5HP 190/380V 23.2/11.6A								SF1.0	

Parts List		
Part Number	Description	Quantity
SA324245	SA 37N905T853G1	1.000 EA
RA312075	RA 37N905T853G1	1.000 EA
HA6361A01	LIFTING LUG FOR 37, 39 & 40 FRAME ZINC	2.000 EA
37CB3006	37 CB CASTING W/1.38 LEAD HOLE @ 6:00	1.000 EA
37GS1000SP	GASKET, CONDUIT BOX STD., .06 THICK LEXI	1.000 EA
51XW2520A10	.25-20 X .62, TAPTITE II, HEX WSHR SLTD	2.000 EA
11XW1032G06	10-32 X .38, TAPTITE II, HEX WSHR SLTD U	1.000 EA
HW3001B01	BRASS CUP WASHER, FOR #10 SCREW	1.000 EA
37EP3203A01	A00 W/FH MTG	1.000 EA
HW4500A01	1641B(ALEMITE)400 UNIV, GREASE FITT	1.000 EA
HA1104A01	RODENT SCREEN 37 FRAME 206 BRG FRONT END	1.000 EA
51XW1032A06	10-32 X .38, TAPTITE II, HEX WSHR SLTD S	4.000 EA
37CB4516	LIPPED LID FOR 37 FRAME NEC KOBX	1.000 EA
37GS1008	37 GS FOR CB LID - LEXIDE	1.000 EA
HW1000A10	#10 FLAT WASHER (SAE)	4.000 EA
HW5100A06	W2420-025 WVY WSHR (WB)	1.000 EA
37EP3401A45	PUEP OPEN 309 BRG NO BAFFLE	1.000 EA
HW4500A17	317400 ALEMITE GREASE RELIEF	1.000 EA
HW4500A01	1641B(ALEMITE)400 UNIV, GREASE FITT	1.000 EA
HA1222	RODENT SCREEN - 37 C-FACE MOTORS	4.000 EA
51XW1032A06	10-32 X .38, TAPTITE II, HEX WSHR SLTD S	4.000 EA
HW1000A10	#10 FLAT WASHER (SAE)	4.000 EA
10XN2520A36	1/4-20X 2 1/4 HEX HD X	4.000 EA
HW1001A25	LOCKWASHER 1/4, ZINC PLT .493 OD, .255 I	4.000 EA

Parts List (continued)		
Part Number	Description	Quantity
XY3118A12	5/16-18 HEX NUT DIRECTIONAL SERRATION	4.000 EA
37FH4000A47	DRIP COVER, W/ PRIMER	1.000 EA
51XW1032A06	10-32 X .38, TAPTITE II, HEX WSHR SLTD S	3.000 EA
51XW0832A07	8-32 X .44, TAPTITE II, HEX WSHR SLTD SE	4.000 EA
HW4600B67	V-RING SLINGER 1.770 X 2.170 X .28 VITON	1.000 EA
HW2501D13	KEY, 3/16 SQ X 1.375	1.000 EA
HA7000A01	KEY RETAINER 7/8" DIA SHAFT	1.000 EA
85XU0407S04	4X1/4 U DRIVE PIN STAINLESS	2.000 EA
LB1115N	LABEL,LIFTING DEVICE (ON ROLLS)	1.000 EA
MJ1000A02	GREASE, MOBIL POLYREX EM - 124047	0.050 LB
MG1000Y03	MUNSELL 2.53Y 6.70/ 4.60, GLOSS 20,	0.028 GA
HA3104A35	THRUBOLT .31-18 X 13.687	4.000 EA
LC0005E01	CONN.DIA./WARNING LABEL (LC0005/LB1119N)	1.000 EA
NP3553LUA	ALUM SUPER-E VPWM INVERTER READY UL	1.000 EA
G0PA1000	PKG GRP, PRINT PK1026A06	1.000 EA
PK3082	STYROFOAM CRADLE	1.000 EA
MN416A01	TAG-INSTAL-MAINT no wire (2100/bx) 4/22	1.000 EA

AC Induction Motor Performance Data

Record # 58178

Typical performance - not guaranteed values

Winding: 37WGT853-R028		Type: 3742M		Enclosure: ODP	
Nameplate Data			460 V, 60 Hz: High Voltage Connection		
Rated Output (HP)	10	Full Load Torque	29.7 LB-FT		
Volts	230/460	Start Configuration	direct on line		
Full Load Amps	25/12.5	Breakdown Torque	87.58 LB-FT		
R.P.M.	1770	Pull-up Torque	44.18 LB-FT		
Hz	60 Phase	Locked-rotor Torque	51.57 LB-FT		
NEMA Design Code	B KVA Code	Starting Current	86.72 A		
Service Factor (S.F.)	1.15	No-load Current	4.91 A		
NEMA Nom. Eff.	91.7 Power Factor	Line-line Res. @ 25°C	1.18 Ω		
Rating - Duty	40C AMB-CONT	Temp. Rise @ Rated Load	34°C		
S.F. Amps		Temp. Rise @ S.F. Load	43°C		
		Locked-rotor Power Factor	37.9		
		Rotor inertia	1.03 LB-FT ²		

Load Characteristics 460 V, 60 Hz, 10 HP

% of Rated Load	25	50	75	100	125	150	S.F.
Power Factor	48	70	80	84	86	86	83
Efficiency	87.7	91.8	92.2	91.7	90.8	89.5	91.4
Speed	1793	1785	1777	1769	1759	1749	1763
Line amperes	5.6	7.31	9.53	12.15	15	18.24	14.2

Performance Graph at 460V, 60Hz, 10.0HP Typical performance - Not guaranteed values

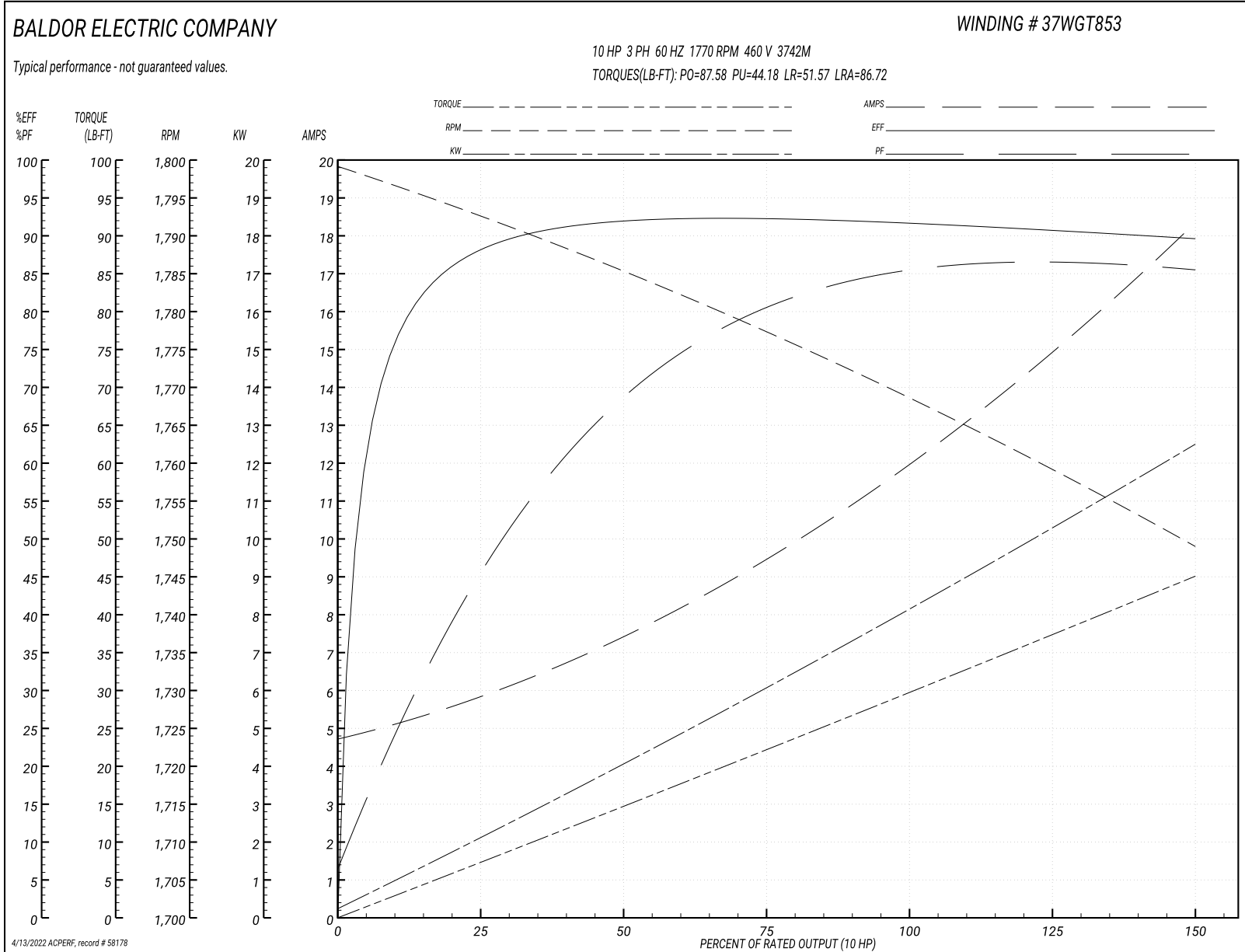

37LYN905

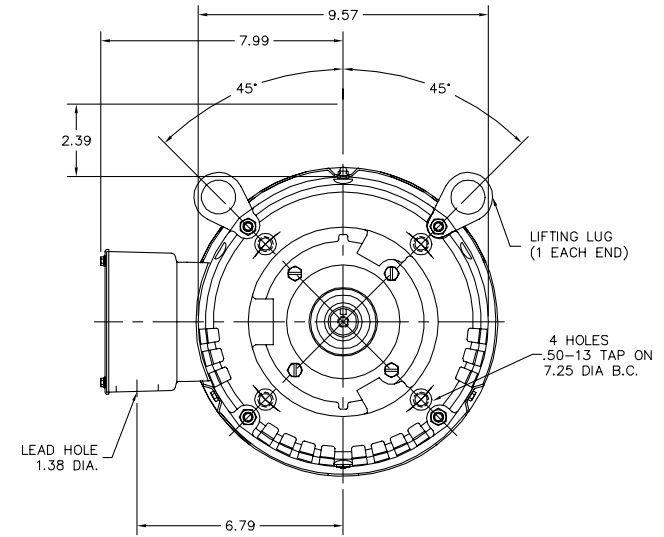
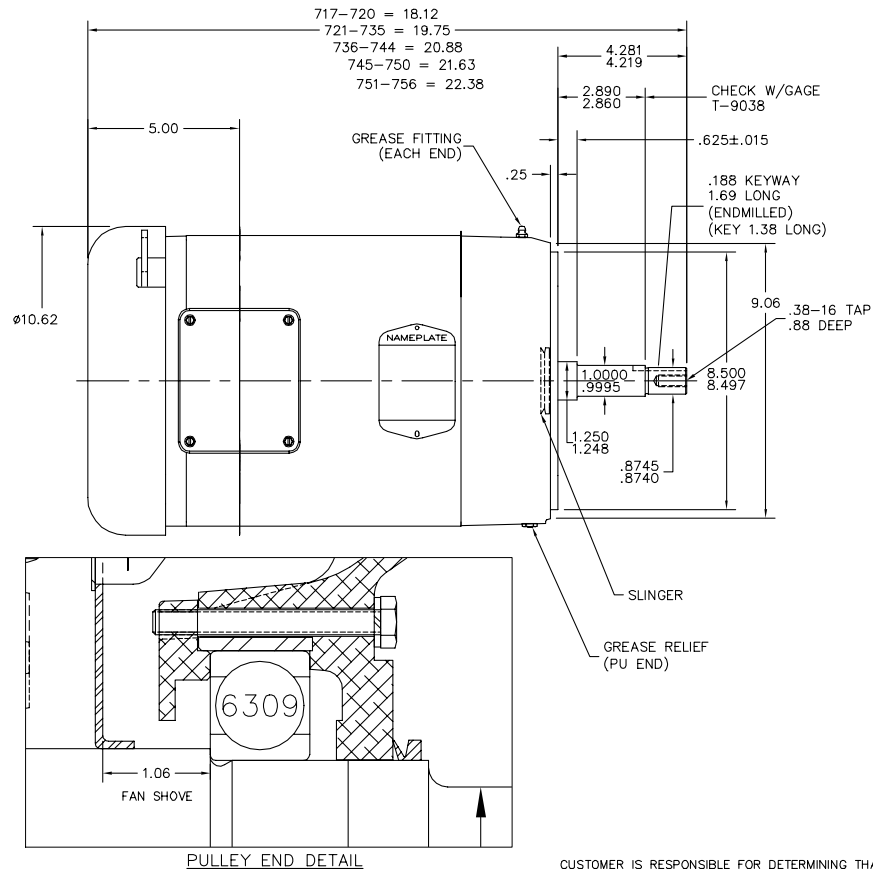

37LYN905

CUSTOMER IS RESPONSIBLE FOR DETERMINING THAT THE PRODUCT WILL PERFORM SUITABLY IN THE INTENDED APPLICATION.

REV. DESC: CHANGE ENDPLATE, REMOVE TIGHT SLEEVE, CHANGE SEAL	TDR: 000001164970
REV. LTR: C	VERSION: 03
FILE: \AAA\00228\020	REVISED: 07:28:28 04/26/2021
MTL: -	BY: ENBRYPO

BALDOR - RELIANCE®

VER 213-5JM OPEN 37M W/DRIP COVER,SCREENS,VERT LIFT,(NO FAN)

SH 1 of 1

CD0005



LOW VOLTAGE
(2Y)



LINE

HIGH VOLTAGE
(1Y)

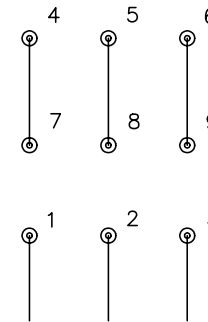

LINE

NOTES:

1. INTERCHANGE ANY TWO LINE LEADS TO REVERSE ROTATION.
2. OPTIONAL THERMOSTATS ARE PROVIDED WHEN SPECIFIED.
3. ACTUAL NUMBER OF INTERNAL PARALLEL CIRCUITS MAY BE A MULTIPLE OF THOSE SHOWN ABOVE.
4. LEAD COLORS ARE OPTIONAL. LEADS MUST ALWAYS BE NUMBERED AS SHOWN.

REV. DESC: REVISE TO SHOW OPTIONAL COLORS			
REV. LTR: E	BY: JLP	REVISED: 01/19/99 10:15	TDR: 0171435
90000		FILE: AAA00005140	MDL: -
		MTL: -	

BALDOR ELECTRIC Co.

3PH, DV, 9 LEADS

CD0005