

図面番号 DRAWING NO.  
P6583052  
REV. MARK  
(2)

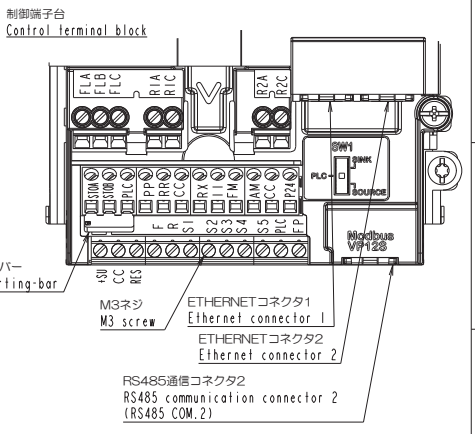
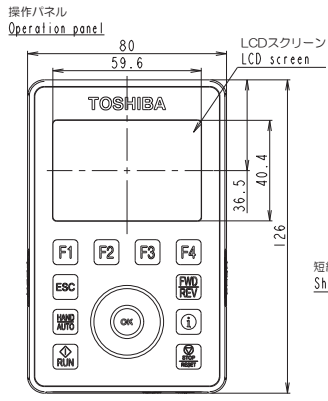
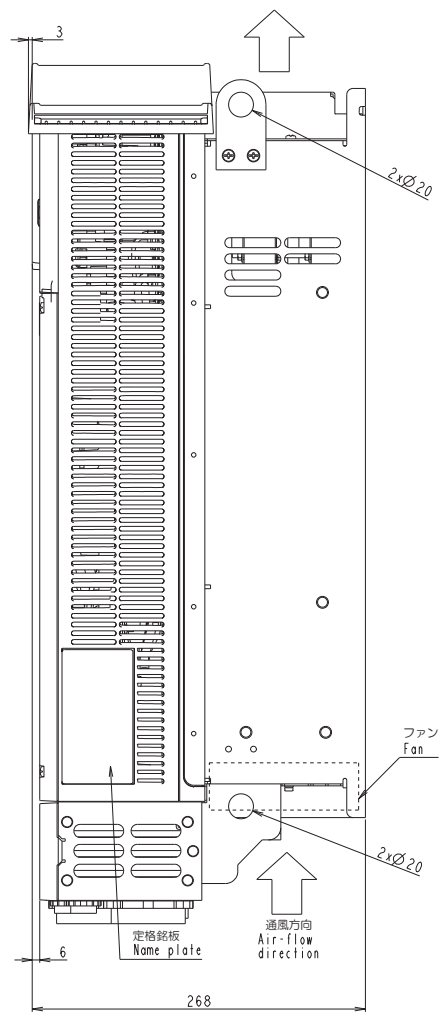
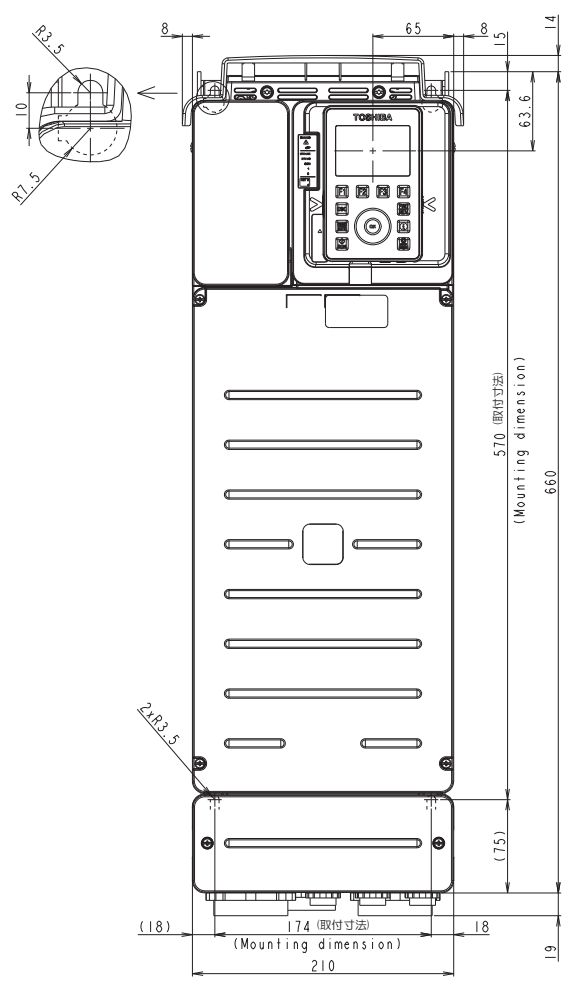

制御端子台  
Control terminal block

主回路端子台  
Main circuit terminal block

for 400V model

for 200V model

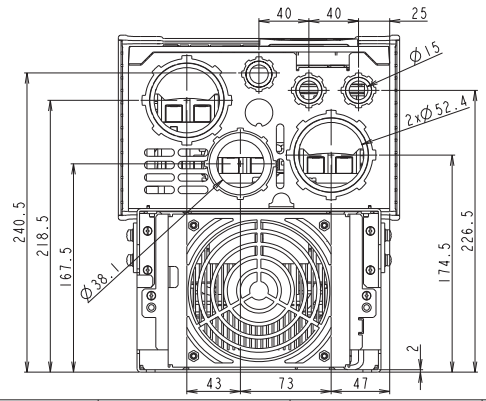
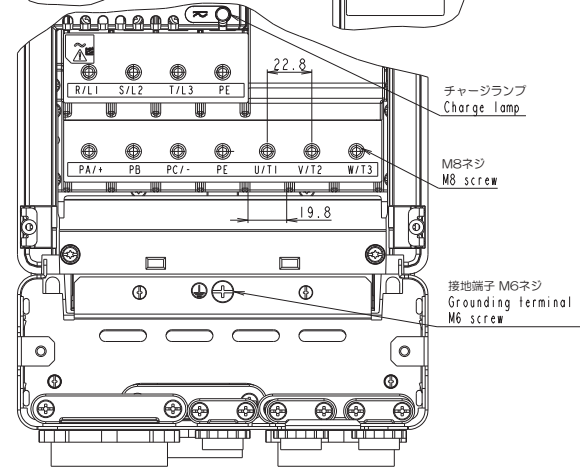
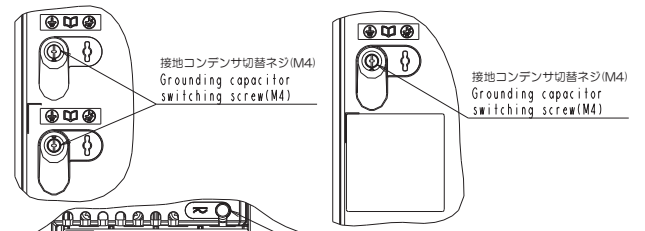

形式 Inverter model	概略質量(kg) Approx. mass
VFAS3-2110P	27.3
VFAS3-2150P	27.3
VFAS3-2185P	27.3
VFAS3-4220PC	28
VFAS3-4300PC	28.2
VFAS3-4370PC	28.7

本体色: RAL7016(Dark grey)  
カバー色: RAL7035(Light grey)  
Box color: RAL7016(Dark grey)  
Front-cover color: RAL7035(Light grey)

記号 MARK	年月日 DATE	承認 APPROVED BY	変更者 REVISED BY	記事 CONTENTS
2	18.Mar.2019	I. Ichio	M. Takeuchi	単位追加。 表記修正。 Added UNITS. Modify some descriptions.
1	26.Sep.2018	I. Ichio	M. Takeuchi	取り付け厚 追加。 Added thickness of mounting plate

INVERTER	VFAS3	2110P, 2150P, 2185P, 4220PC, 4300PC, 4370PC
器具名称 APPARATUS	形 TYPE	式 FORM
承認 APPROVED BY I. Ichio 30.Oct.'15	検閲 CHECKED BY M. Takeuchi 30.Oct.'15	名称 TITLE インバータ外形図 OUTLINE OF INVERTER
設計 DESIGNED BY S.Oi 30.Oct.'15	製図 DRAWN BY S.Oi 30.Oct.'15	TOSVERT VF-AS3 SERIES
TOSHIBA 東芝エレクトロニクス株式会社 Toshiba Schneider Inverter Corporation		図面番号 DRAWING NO. P6583052
保管 REGISTERED	REV. MARK (2)	配布先 PRESENT TO