

DATE
Jan. 14, 2012
CAT. #: VHP7/54

OUTLINE DIMENSIONS
3-PHASE INDUCTION MOTOR

MOTOR TYPE:
AMRCNH
FRAME NO. 213TP

Pole	HP	kW	Hz	VOLT	Syn.Speed r/min(rpm)
4	7.5	5.6	60	230/460	1800

Ins	Rating	Dimension in	Approx Weight	Bearings
F	CONT.	inches	198 lbs	DE: 6209ZZC3 NDE: 7310BE

NEMA Weather Protected TYPE I (WP I) Squirrel-cage Rotor.

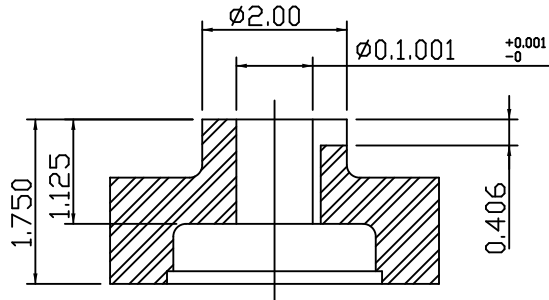
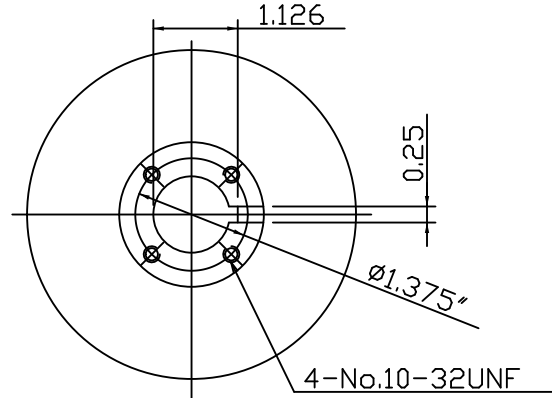
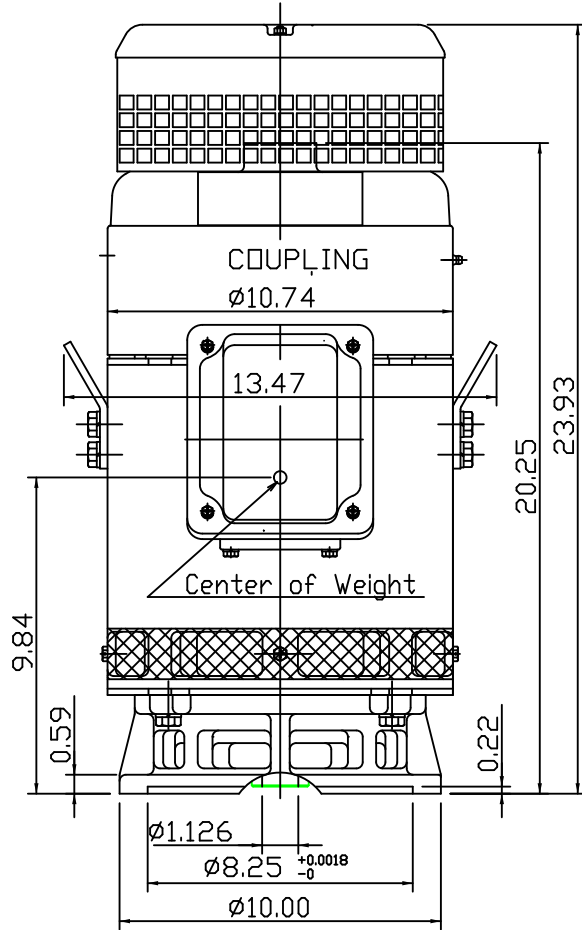

Coupling Dimension

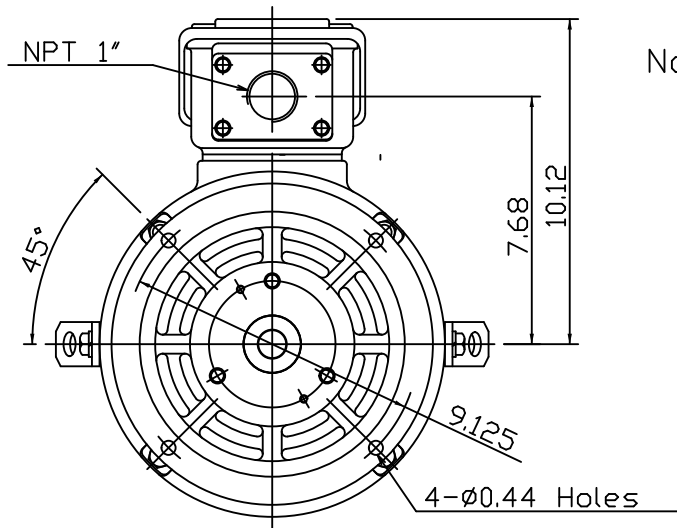

Note:

1. Downthrust :2600lbs
L10 - 8800 hours
2. Rotation: C.C.W
View from Top
3. With N.R.R.
4. Approx Reed
Frequencies: 131 Hz

12.27.08

DWN.	????????	12 14 08
CHKD.	???????	01 09 09
APPD.	????????	01 09 09

TECO Westinghouse

DWG NO.
31049R179101A

TECO Westinghouse

ISSUED January 15, 2015	PERFORMANCE DATA	ENCLOSURE WP1
TYPE AMRCNH	3-PHASE INDUCTION MOTOR	CATALOG# VHP7/54

NAMEPLATE INFORMATION

OUTPUT		POLE	FRAME SIZE	VOLTAGE	HZ	RATED AMBIENT	INS. CLASS	NEMA DESIGN	TIME RATING	SERVICE FACTOR
HP	KW									
7.5	5.6	4	213TP	230/460	60	40°C	F	B	CONT.	1.15

TYPICAL PERFORMANCE

FULL LOAD RPM	EFFICIENCY				POWER FACTOR			MAXIMUM POWER FACTOR CORRECTION
	FULL LOAD		3/4 LOAD %	1/2 LOAD	F. L. %	3/4 LOAD	1/2 LOAD %	
	MIN. %	NOM. %						
1755	89.5	91.0	91.5	91.0	81.0	76.0	64.5	2.5 KVAR

CURRENTS

NO LOAD			FULL LOAD				LOCKED ROTOR		NEMA KVA CODE LETTER
AT 230 VOLT		AT 460 VOLT	AT 230 VOLT	AT 460 VOLT		AT 230 VOLT	AT 460 VOLT		
6.34		3.17	19.1	9.5		127.0	63.5	H	

TORQUE

INERTIA

ACCEL TIME

FULL LOAD lb-ft	LOCKED ROTOR %FLT	PULL UP %FLT	BREAK DOWN %FLT	ROTOR WR ² lb-ft ²	NEMA LOAD WK ² lb-ft ²	MAX ALLOWABLE WK ² lb-ft ²	NEMA LOAD WK ² Sec	MAX ALLOWABLE WK ² Sec
22.44	220	175	260	0.67	39	82	4.58	9.54

SAFE STALL TIME IN SECONDS

ALLOWABLE STARTS PER HOUR

SOUND PRESSURE LEVEL @ 3 FT dB(A)

DOWNTHRUST L10:8800 HOURS

COLD
17

HOT
12

COLD
2

HOT
1

72.4

2600

APPROVED:	M. PRATER	DRAWING NO.	31057VHP7/54	REVISION 0
-----------	------------------	-------------	---------------------	-------------------

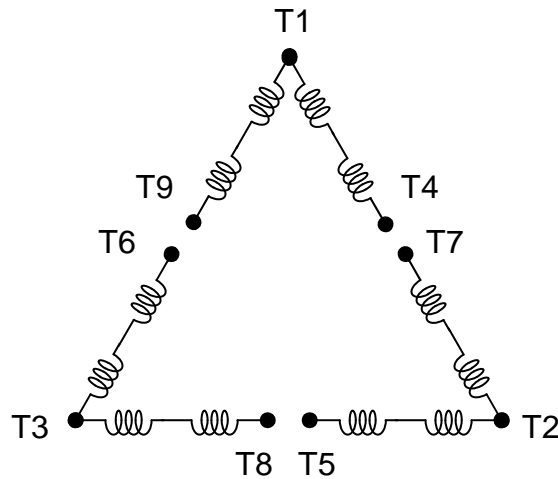

SCHEMATIC – 2 Δ / Δ CONNECTION

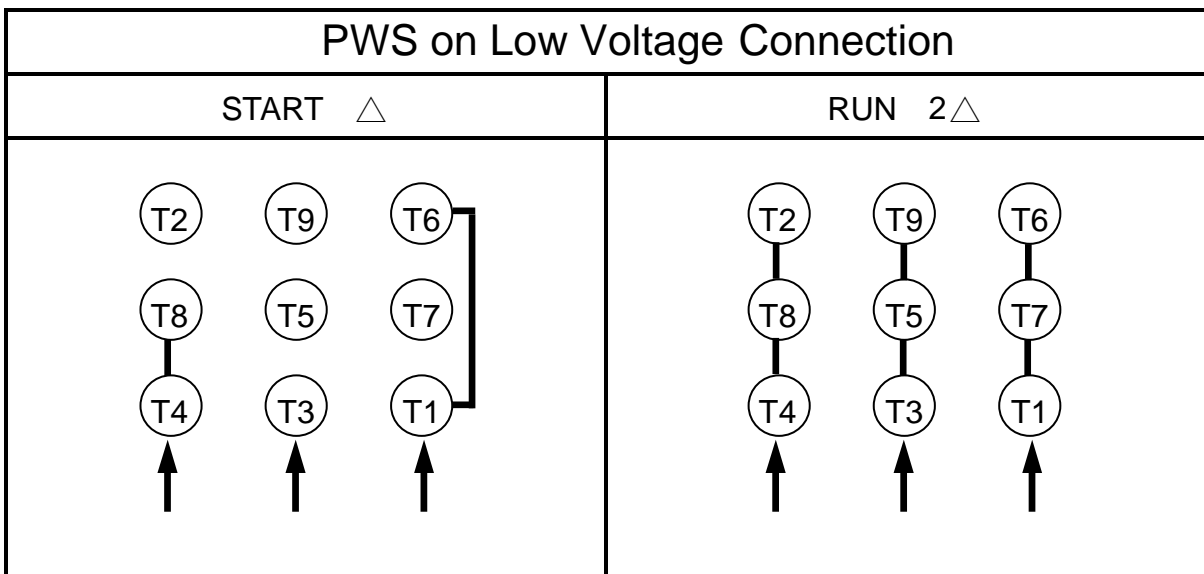
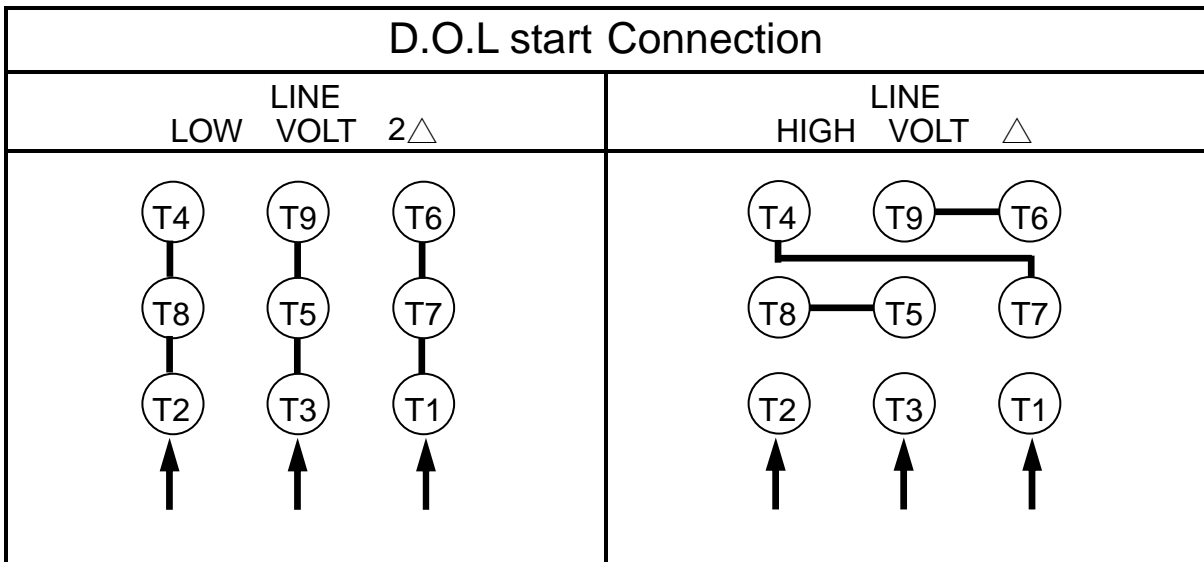

APPD.	M.C.Tsai	May,05,'09
CHKD.	C.L.Huang	May,05,'09
DWN.	J.C.Lan	May,04,'09

TECO Electric & Machinery Co., Ltd.

DWG NO :
DAC-1703